

HM 18-Gun Brig-Sloop

HARPY 1796

Building Manual

PART NUMBER - VM-17

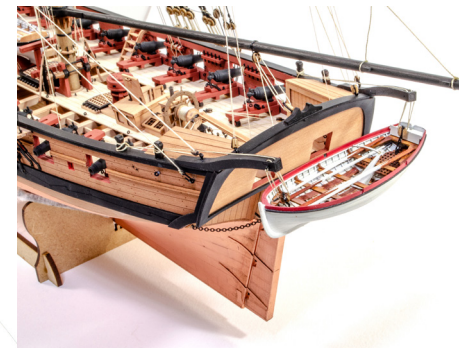
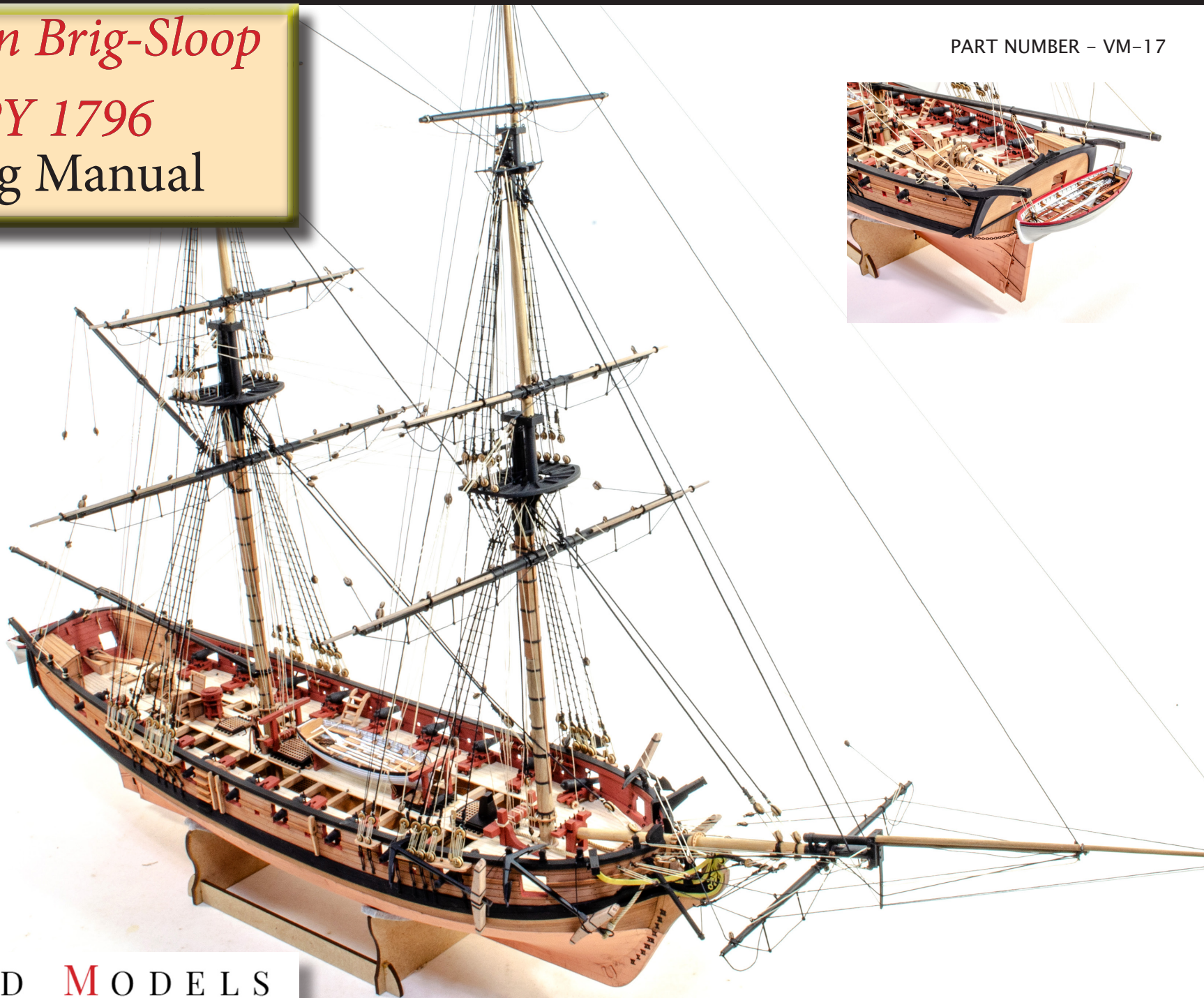

VANGUARD MODELS

BY CHRIS WATTON

HM 18-GUN BRIG SLOOP

HARPY - 1796

HISTORY

HMS Harpy was a Royal Navy Diligence-class brig-sloop, launched in 1796 and sold in 1817. She was the longest lived vessel of her class, and the most widely travelled. She served in both the battle of Copenhagen and the British invasion of Java, took part in several actions, one of which won for her crew a clasp to the Naval General Service Medal, and captured numerous privateers. The Navy sold her in 1817.

Tons burthen - 316

Length - 95 ft 0 in (29.0 m) (gundeck)

Keel - 75 ft 1+5/8 in (22.9 m) (gundeck)

Beam - 28 ft 1+1/2 in (8.6 m)

Depth of hold - 12 ft 0+1/2 in (3.7 m)

Sail plan - Brig

Complement - 121

Armament:

16 × 32-pounder carronades

2 × 6-pounder chase guns

French Revolutionary Wars

Commander Henry Bazely commissioned Harpy in April 1796, for The Downs. Harpy belonged to the squadron that on 20 August captured Augustic and recaptured Nelly. Consequently Harpy was entitled to share in the prize money.

On 25 December, Harpy captured Hoop, Pronck, master. Harpy was in company with the hired armed cutter Hind. Ragoon also shared in the proceeds of the capture.

On 3 February 1797 Harpy was off Dungeness Point when she fell in with the hired armed cutter Lion, which was in the process of detaining a sloop that had been trailing a convoy. The sloop turned out to be the French privateer Requin, of Dieppe, which had a crew of 20 men armed with small arms. Lion was in company with hired armed cutter Dolphin.

The next day Harpy recaptured Liberty, of Newcastle, which had been a prize to Requin. Harpy took both into Portsmouth.

Also in February, Harpy captured the privateer Cotentin. On 8 May, Harpy captured the Russian hoy Leyden and Fourcoing, which was sailing with a cargo of madder, white lead, and smalt, from Rotterdam to Rouen. Harpy was in company with Beaulieu and Savage. Eight days later Harpy captured Goede Hope; Harpy was in company with the hired armed cutter Princess of Wales.

Then on 26 May Harpy recaptured Friendship. Friendship had been sailing from Southampton to Leith and Harpy took her into Dover.

A biography of Bazely reports that in May Harpy drove a French brig of eighteen 9-pounder guns and a cutter of 14 guns on shore near Dieppe. Furthermore, in connection with that action, Harpy fired on the

buildings of the port, damaging several, including particularly the Customs House.

On 20 June Harpy captured the French privateer Espérance. Espérance was a rowboat, armed with 10 swivel guns and having a crew of 32 men, and the capture took place off the coast of France.

The same biography of Bazeley reports that Harpy had captured two privateers, one of four guns and the other a rowboat, and recaptured two coasting vessels. The description of the rowboat matches that of Esperance, suggesting that the privateer of four guns may have been Cotentin.

In May 1798 Harpy participated in Sir Home Riggs Popham's expedition to Ostend to destroy the sluice gates of the Ostend-Bruges Canal. Harpy led the smaller vessels that were to lie as beacons N. W. of Ostend. The expedition landed 1,300 troops under Major General Coote. The army contingent blew up the locks and gates of the canal, but due to unfavourable winds preventing re-embarkation, Coote and the men under his command were then forced to surrender.

Harpy recaptured the ship Pleaaden in October.

On 20 May 1799 Harpy and Suffisante were in sight when Savage captured the ship Johanna Maria. On 3 June Babet was in company with Harpy when they captured John. Then on 24 June they captured the ship Weloverdagt.

Early in the morning of 5 February 1800, the sloops Fairy and Harpy left Saint Aubin's Bay, where they were attached to the Jersey squadron under the command of Captain Philippe d'Auvergne, (Prince of Bouillon), and reconnoitered the coast around Saint-Malo. In late morning they were some five or six miles from Cap Fréhel when they sighted a large vessel, which turned out to be a French frigate.

The sloops were able to lure the frigate away from the coast and an action developed that lasted from 1pm to 2:45pm before the French vessel sailed away. The sloops had a lot of damage to their rigging but once this was repaired they set out in pursuit. At 4pm they encountered the British frigate Loire, the sixth-rate post ship Danae, and the ship-sloop Railleur, which joined the chase. That evening, after a close action of more than two hours, Loire succeeded in getting the 42-gun French frigate Pallas to strike. Pallas was on her maiden voyage and the Royal Navy took her into service as Pique. The next day, Danae was able to capture a French naval cutter.

The British vessels suffered some casualties. Fairy had four men killed and seven wounded, among them her captain. Harpy had one man killed and three wounded. Loire had two men killed and 17 wounded, one of them mortally. Lastly, Railleur had two men killed and four wounded. Captain James Newman Newman of Loire did not report the French casualties.

The action resulted in promotions to post captain for both Captain Joshua Sidney Horton of Fairy and for Bazely. Horton was promoted on 18 February, but Bazely was not promoted until 8 April due to some ambiguity about Harpy's role in the capture of Pallas. In 1847 the Admiralty awarded the Naval General Service medal with clasps "Fairy" and "Harpy" to the surviving claimants from the action. Captain William Birchall, of the troopship Hebe replaced Bazely on Harpy.

Two French privateers, each of 14 guns and 90 men, captured the Constitution on 9 January 1801 off the Isle of Portland. Constitution was a hired cutter of twelve 4-pounder guns and 40 men, under the command of Lieutenant W.H. Faulknor. That same evening Harpy and the revenue cutter Greyhound

recaptured Constitution.

On 2 April 1801, Harpy was in Admiral Lord Nelson's division at the battle of Copenhagen. She apparently was not involved in the actual fighting as she suffered no casualties. Commander Charles Boys replaced Birchall, but shortly thereafter Harpy was paid off.

Napoleonic Wars

Commander Edmund Heywood recommissioned Harpy in August 1803 for the North Sea.

On 21 October 1803 Captain Robert Honyman of Leda sighted a convoy off Boulogne of six French sloops, some armed, under the escort of a gun-brig. He sent Harpy and Lark to pursue them but the winds were uncooperative and the squadron was unable to engage. However, the hired armed cutter Admiral Mitchell was able to come up and attack the convoy. After two and a half hours of cannonading, Admiral Mitchell succeeded in driving one sloop and the brig, which was armed with twelve 32-pounder guns, on the rocks. Admiral Mitchell had one gun dismounted, suffered damage to her mast and rigging, and had five men wounded, two seriously.

Harpy intercepted a small French convoy on 12 March 1804 that was sailing from Calais to Boulogne. Harpy was able to capture two transports and their escort, a gunboat named Penriche armed with two guns, and send them into The Downs. A later report referred to Penriche as French Gun Boat No. 1. The two transports were Schuyt No. 23, and Schuyt No. 24. Harpy shared the capture with Aggressor.

In the evening of 20 July there were more than 80 French brigs and luggers in the roads of Boulogne. As the weather worsened, a number of the vessels set sail. Captain Owen of Immortalite signaled to Harpy, Bloodhound, and Archer to close with the vessels, which they did. Autumn also joined the operation. Although most of the French vessels escaped, the British were able to drive a handful on shore.

On 26 August Immortalite, Harpy, Adder, and Constitution attacked a French flotilla of 60 brigs and luggers off Cape Gris Nez. The British vessels were within range of shore batteries that fired on them. A 13" shell fell into Constitution, falling through the deck and hull without exploding. Water started coming in faster than the pumps could handle and her crew abandoned her; the other vessels in the squadron rescued them. A shell hit Harpy too, also without exploding. It killed a seaman as it hit, and the crew speculated that his blood had extinguished the fuse. Another account had the shell breaking a beam, which tore out the fuse. When the shell came to rest, a seaman picked it up and plunged it into a bucket. Some shots hit Immortalite, wounding four men. The British succeeded in driving some vessels ashore, but the great bulk of the flotilla reached Boulogne. The British squadron engaged in some small skirmishes over the next two days, but without notable results.

On 29 January 1805 a French flotilla consisting of 17 brigs, three schooners, four sloops, a dogger, and six luggers arrived at Boulogne from the west. Immortalite exchanged fire with them but they were too close to shore to capture. One lugger lost her foremast and Harpy was able to capture her after a brief exchange of fire. Owen sent the lugger to the Downs with Bruiser. A subsequent prize money notice named the lugger as Gunboat No. 337 (or No. 317); Watchful and Immortalite shared in the capture.

Early on the morning of 24 April Gallant and Watchful sighted a flotilla of 27 vessels under Dutch colours coming around Cape Grisnez and approaching Boulogne from the east. The two brigs engaged, giving the squadron under command of Captain Robert Honyman in Leda time to join the action. Gallant received four shot between wind and water and had to sail back to Britain to effect repairs; she had no casualties. Watchful captured one of the vessels.

Honyman led the rest of his squadron, consisting of Fury, Harpy, Railleur, Bruiser, Archer, Locust, Tickler, Monkey, and Firm, in chase. After an engagement of about two hours the British succeeded in capturing seven schuyts (including the one that Watchful had captured earlier). All were from 25 to 28 tons burthen, six were armed with from two to three guns and howitzers ranging from 6 to 24-pounders, and were carrying troops from Dunkirk to Ambleteuse. Most were under the command of army officers. One, No. 3, was a transport. British casualties amounted only to one man wounded. Archer, in a separate letter, reported capturing two more schuyts similarly armed and manned. A number of other British vessels in the squadron under Admiral B. Douglas also shared in the prize money because they were part of the blockading force, even though they were not present; however, the head money for the crews of the armed schuyts accrued only to the actual captors, including Harpy.

In January 1806 Commander George Mowbray assumed command of Harpy. However, she was paid-off into ordinary at Portsmouth in 1807. She then underwent some repairs between April and July 1809, with commander George Blamey recommissioning her in May.

Harpy participated in the unsuccessful Walcheren Expedition, which took place between 30 July and 19 August 1809. She was part of a squadron of smaller vessels under Sir Home Riggs Popham that pushed up the West Scheld to place buoys in the channel to guide the large ships, but saw no action. Blamey apparently also commanded a battery on shore, manned by seamen, that fired on Flushing. Prize money was paid in October 1812 to the naval vessels, customs house vessels, and Sea Fencibles.

After the evacuation of Walcheren, Harpy sailed with a convoy to Halifax, leaving on 13 May 1810. She then brought 150 troops back with her and took them to Lisbon.

In October 1810, Harpy detained and sent into Falmouth Aurora, Rohly, master, of Ostend.[42] Blamey received promotion to post captain on 21 October. Commander Edward A'Court took command in November and sailed Harpy for the Cape of Good Hope on 2 January 1811.

Commander Henderson Bain was appointed to command Harpy on 29 March 1811 at the Cape of Good Hope. That same day, the newly promoted Lieutenant Henry Cavendish Hore joined Harpy.

Harpy then participated in the British invasion of Java commanded by Admiral Stopford. Hore received a knee wound while commanding a detachment ashore in the storming of Fort Cornelis.

Prize money for the capture of Java was payable in July 1816.

On 26 January 1812 Bain became acting captain of Lion. Lieutenant Henry Cavendish Hore moved with Bain to Lion as her first lieutenant. During Bain's absence, Lieutenant Samuel Hore commanded Harpy. He was Admiral Stopford's Flag Lieutenant, and Stopford appointed him to Harpy to replace Bain. On 28 January Stopford sent Hardy to Isle de France to replace Eclipse.

Harpy captured James, which was sailing from Batavia to Philadelphia; James arrived at the Cape of Good Hope on 21 January 1813. Racehorse and Harpy captured the American ship Rose on 3 February. She was carrying tea and 8907 Spanish dollars (worth approximately £2226).

Bain returned to command of Harpy a few weeks before he received promotion to post captain on 6 April 1813. Commander Thomas Griffith Allen replaced Bain that month. However, he died on 26 (or

28) September 1814, at Port Louis. Command devolved on Lieutenant William Lambert, Harpy's first lieutenant. Earlier, in July, Lambert had led her boats in the rescue, at great risk, of the crew of the schooner *Eugenie*, which had wrecked on Sandy Island (near Mauritius) on 19 April. During the rescue the master and a seaman from Harpy drowned when their boat overturned. After Allen's death, Robert Townsend Farquhar, governor of Mauritius, wrote to Lambert, pressing on him the importance of maintaining Harpy's highly successful anti-slavery mission.

In February 1815, Commander George Tyler took command of Harpy. On 16 November 1815 Harpy captured the French schooner *Jeune Victor*, which was carrying 55 slaves. *Victor* was sailing from Madagascar to the Mauritius when Harpy captured her and sent her into the Cape of Good Hope. The account in Lloyd's List further describes *Victor* as having 64 slaves on board.

Fate

The Commissioners of the Navy first offered Harpy for sale at Deptford on 3 April 1817. They sold her on 10 September to a Mr. Kilsby for £710.

References

- Hepper, David J. (1994). *British Warship Losses in the Age of Sail, 1650–1859*. Rotherfield: Jean Bodriot. ISBN 0-948864-30-3.
- James, William (1837). *The Naval History of Great Britain, from the Declaration of War by France in 1793, to the Accession of George IV*. Vol. 3. R. Bentley. pp. 29–32.
- Marshall, John (1824a). "Owen, Edward William Campbell Rich". *Royal Naval Biography*. Vol. 2, part 1. London: Longman and company. pp. 127–130.
- Marshall, John (1824b). "Bazely, Henry". *Royal Naval Biography*. Vol. 2, part 1. London: Longman and company. p. 250–253.
- Marshall, John (1828). "Blamey, George William". *Royal Naval Biography*. Vol. sup, part 2. London: Longman and company. p. 275.
- Marshall, John (1829). "Bain, Henderson". *Royal Naval Biography*. Vol. sup, part 3. London: Longman and company. pp. 123–124.
- Norie, J. W. (1827). *The naval gazetteer, biographer and chronologist; containing a history of the late wars from ... 1793 to ... 1801; and from ... 1803 to 1815, and continued, as to the biographical part to the present time*. London: C. Wilson.
- O'Byrne, William R. (1849). "Hore, Henry Cavendish". *A Naval Biographical Dictionary*. London: John Murray. p. 541.
- Theal, George McCall, ed. (1902). *Records of the Cape Colony: March 1811–October 1812*. Vol. 8. Government of the Cape Colony.
- Winfield, Rif (2008). *British Warships in the Age of Sail 1793–1817: Design, Construction, Careers and Fates*. Seaforth Publishing. ISBN 978-1-86176-246-7.

THE KIT

Although this kit has many parts, this does not mean it is more complicated than standard/legacy kits you may be used to. It simply means that more parts are pre-made/cut than most other kits of this class, meaning you do not have to manufacture the parts yourself from wood stock supplied in the kit. This model kit is designed to be as accurate as possible for a commercial kit in both scale and detail. Although HMS Harpy is as easy to build as we can make it, very basic woodworking skills (and patience) are still required. Estimated build time is around 150 hours, so a work space will have to be put aside for the job. Do not remove parts from the laser cut sheets until actually required for fitting, as they can be easily damaged or lost. We recommend all planks and laser cut parts that require bending, are 'pre-bent' before gluing.

PLEASE NOTE - This is very important.

Take plenty of time to study this manual until you are confident enough to tackle each stage of construction. Patience is the key word when building any scale model. Treat each stage as a separate project and the overall effect of the completed subject will be much enhanced.

Care should be taken when cutting parts from the laser and brass etched sheets. The sheet from which you are going to cut the parts should be laid on a hard, flat surface. Use a heavy-duty craft knife (a Stanley Knife is perfect and is and always has been my staple for all manner of cutting) with a good strong blade to cut through the tabs holding the parts in place. It is easier to paint most of the photo-etched parts before removing them from their sheets. They can be touched up again once in place on the model. When painting parts in wood, use multiple coats with fine sanding in-between each coat to help minimise the grain visibility. Never settle on just a single coat, but instead take your time with every single sub assembly. Consider using a coat of flat varnish under your paint too.

We have included a building cradle on the 2mm MDF laser sheet that is for use when building the model. Do not make up the clear acetate cradle until the model is complete. Any heat discolouration due to laser cutting/engraving can usually be removed with a very light surface sanding with 320/400 grit, being careful not to damage engraved detail. Then to use a stiff brush to remove any dust from engraved details afterwards.

Finally, Harpy's skill level is 'Experienced'. You should have a number of successful projects completed and that you possess more than just a basic skill set. You must be forward-thinking as you work and be able to adapt your skills to create the many features you would expect to see on a kit of this standard. There will be techniques you must use here which aren't applicable to our earlier level kits, such as hull coppering and more extensive photo-etch etc.

It should also be noted that a large portion of initial assembly is made with very little to no glue, unlike legacy kits. This is for a reason. Our kits have a large number of accurate slots that all need to interlock. You can build the basic hull without much glue, ensuring that the framing and inner keel are perfectly straight. If they are not, you can then disassemble your work and retrace to where the error occurs, putting it right. Only when everything is seated and in alignment, should you then paint slightly diluted wood glue into the joints. This kit DOES fit perfectly if you follow that simple instruction.

Disclaimer

In our continuing effort to improve our product we reserve the right to change plans, features, specifications, prices and materials without notice or obligation.

Wood is a natural material and whilst we try hard to attain an even colour/shade in each batch, this cannot always be guaranteed, even with the highest quality materials Vanguard Models uses. Where there is colour variation, for example, planks, try to utilise these appropriately (darker/lighter planks below the waterline etc.)

Recommended tool list

(All items listed were used by the modeller to build the Harpy prototype model)

- 1: Craft knife (or standard Stanley Knife, which is robust enough for most jobs)
- 2: A selection of needle files
- 3: Razor saw
- 4: Pin vice or small electric drill.
- 5: Selection of drill bits from 0.5mm to 4mm
- 6: Selection of abrasive paper and sanding block (110, 180, 240, 320, 400)
- 7: Selection of good quality paint brushes
- 8: Pliers/wire cutters (Good quality side-cutters are excellent for trimming rigging ends)
- 9: Good quality set of tweezers (For small parts and rigging)
- 10: Steel ruler (300mm - for providing a straight edge for tapering the planking)
- 11: Small clamps (2 inch clamps with rubber tips, are very useful for projects like this)
- 12: Good quality pencil or drawing pen
- 13: Masking tape (Tamiya masking tape is perfect for masking areas around the main wale)
- 14: Waterline marking tool
- 15: A Pin Pusher (Or you can just use a pair of pliers to push pins into the planking and bulkhead edges)
- 16: Cutting mat

Recommended Paints, stains and adhesives

- 1: White PVA wood glue or suitable Titebond adhesive.
- 2: Cyanoacrylate (superglue) thick and medium viscosity
- 3: Natural colour wood filler (Water based wood filler is recommended as this can be diluted and made thinner)
- 4: Matt polyurethane varnish (Not satin or gloss)

- 5: Paints:
BLACK
OCHRE
MATT RED
VARNISH MATT



Recommended tools from Vanguard Models



Our waterline marking tool is supplied in a sheet of laser-cut, 4mm plywood that needs assembly. Assembly time is around 15 minutes and very easy. Metal fittings are supplied to aid the change in position of the pencil carriage. Vanguard Models pencil is supplied with each tool.

The Waterline Marker will mark a level from between 25mm to 150mm, and an engraved gauge will help you achieve the correct level.



Pin Pusher With Adjustable Depth Stop

This is a slightly larger version of our other pin pusher, and has the added advantage of an adjustable depth stop to ensure that all pins are pushed 'home' to the same depth. It is ideal for model boat/ship hull planking, and setting miniature n-gauge rail track on to board, or for nailing tasks on wooden boat models, dolls houses and picture frames.



Pocket sized Pin Pusher

Can push pins in to 9mm of plywood or MDF
Ideal for pushing brass pins
Nailing, pin pushing or riveting can be frustrating if the wrong type or an oversized hammer is used. Not to mention the dangers involved. Small pins and nails should be driven in using a precision tool rather than a regular DIY hammer. Pin pushers will make inserting small panel pins and nails a breeze and virtually eliminate sore thumbs!



This plank bending tool is the ideal boat modeller's tool for the bending strips to the desired curvature. Used for perfect and precise bending of all wooden strips, such as planking on model boats up to 2mm thickness. For bending at an angle, change the cutting angle and the plank will 'spiral'. The more cuts produced the tighter the bend. Includes a plastic blade stopper.





Ideal for bending planking strips to the desired curvature
 Modelcraft Plank Bending Tool Kit 220-240v, 30w

- The Plank Bending tool is ideal for bending planking strips to the desired curvature
- The rounded head on the tool should be warmed up and the wooden strip should be placed on the wooden template form. The strip is then heated by running the tool head over it a few times until the required curve is achieved.
- It works on dry strips with a maximum thickness of 1mm
- For thickness over 1mm, the strip must be dampened
- Set includes: Tool with a rounded head, tool stand & wooden template form.
- Use with caution as parts will be hot



Pin Vice and Drill set

Pin Vice – Double Ended (0 – 2.9mm)
 Handy holder for drills, taps, pins etc. Including: 2 reversible collets, with capacities 0-1.2mm, & 1.3-2.4mm and 0.8-2.0mm, & 1.8-2.9mm. Incorporating an Anti-roll 6-sided body.

Drill bits
 Our Drill Bits are made of high quality tungsten steel, have high wear resistance, precision, and are beautifully sharp. This Set contains 10 different size drill bit diameters: 0.3mm, 0.4mm, 0.5mm, 0.6 mm, 0.7 mm, 0.8 mm, 0.9 mm, 1 mm, 1.1mm, 1.2mm.



Spring-Loaded Finger Sanders available in 4 sizes, 10mm, 20mm, 25mm, 40mm (Medium Grade)
 Unique shape for flat and curved surfaces
 Easy to fit band with spring mechanism

These sanders have a unique shape for working on both flat and curved surfaces and come with pre-fitted medium sander band. The sanders also have an ergonomic shape meaning that they're comfortable when in use.

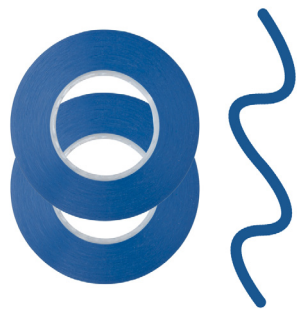

Flexible Masking Tape x2

This is available in TWO sizes, and there are two rolls in each packet.

3mm wide x 18m long
 6mm wide x 18m long

Absolutely ideal for masking hull waterlines! These masking tapes are also ideal for general modelling, airbrushing, arts, crafts, and even those smaller DIY tasks. The tape sticks, stays and removes cleanly. This flexible acid-free tape is designed to follow curved lines and contoured surfaces without creasing, tearing or paint bleed.



HULL CONSTRUCTION

1. Use a sharp knife to remove all parts from various wood and MDF sheets. We suggest either an X-Acto, scalpel, or Stanley knife. If the blade won't go through on one pass, flip the sheet over and cut the tabs from the underside too.



2. From the 3mm MDF sheet, remove parts 18, 19, and 20.



3. It is good practice to either shave or sand away the nub that's left over from removing the part from its sheet.



4. Assemble the parts as shown here. You can either glue as you go or assemble and then paint glue into the joints. The latter method is what we will use as we build the basic hull.

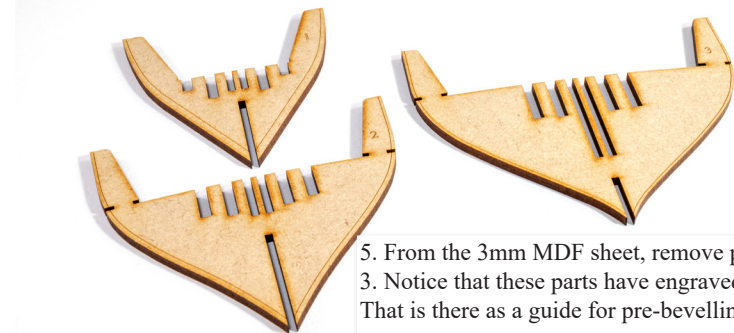

5. From the 3mm MDF sheet, remove parts 1, 2, and 3. Notice that these parts have engraved lines on them. That is there as a guide for pre-bevelling the parts.



6. Use a sanding stick or rotary tool to bevel them as shown. Please remember to wear a face mask when you do any sanding of MDF.

7. From the 2mm MDF sheet, remove part 21. This is the inner keel which runs down the middle of the hull.

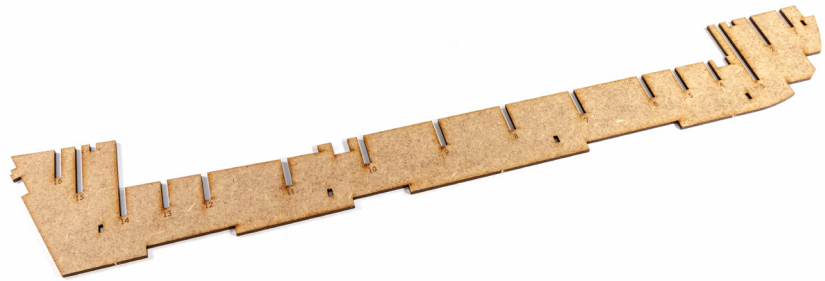

8. Notice how each slot is numbered. Those numbers correspond with the bulkheads which you will slide into these.

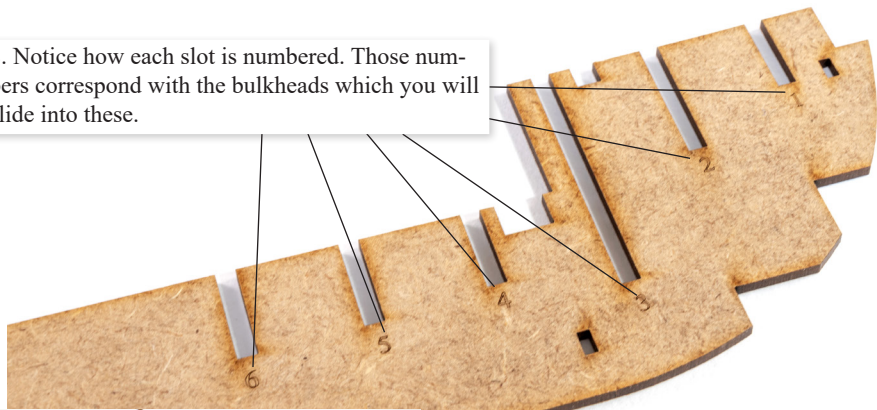

9. Take those first three, bevelled bulkheads and slot them into the inner keel as shown here. **DO NOT GLUE!** Note that the bevelled side faces forward, towards the bow.



10. From the 3mm MDF sheet, remove parts 4 through to 12.



11. Slide these bulkheads onto the inner keel as you did with the first three. **DO NOT GLUE!** Make sure they are slotted all the way down. No force will be needed for any of these parts.



12. Now remove parts 13 through to 17, from the 3mm MDF sheet.

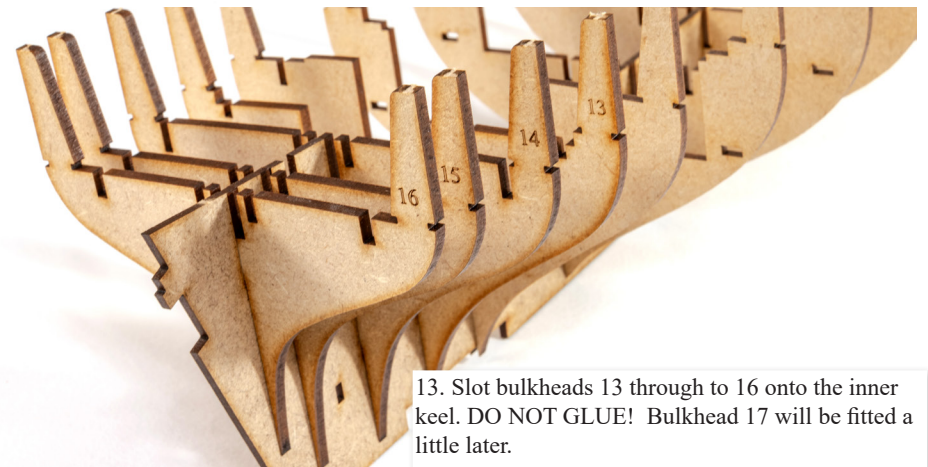

13. Slot bulkheads 13 through to 16 onto the inner keel. **DO NOT GLUE!** Bulkhead 17 will be fitted a little later.

14. This is what your HMS Harpy will currently look like. A little floppy, and the bulkheads will jiggle from side to side a little. That is normal and how it's been designed. Time to strengthen things a little.



15. From the 2mm MDF sheet, remove both parts 22.



16. These fit into the innermost slots on each bulkhead, either side of the inner keel, right up against the inner keel itself. **DO NOT GLUE!** Remember that these parts have a bow and stern end. You will be able to see which end of the part is the bow, from its shape and the slot spacings. You can see in these photos, how these parts look when fitted.

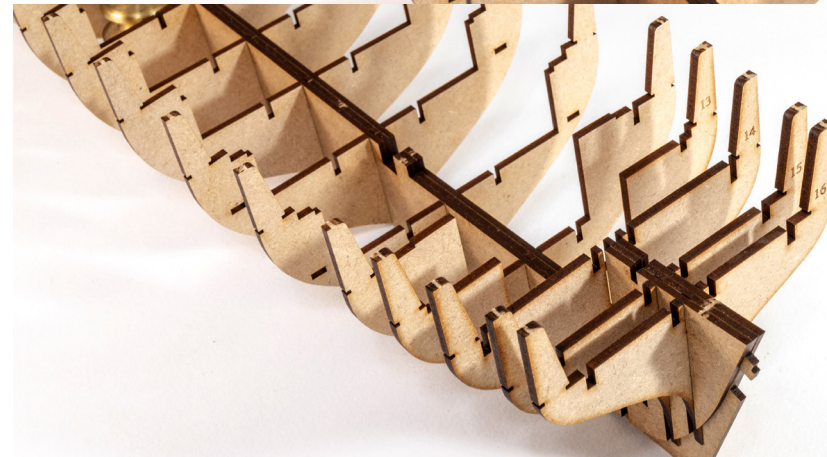
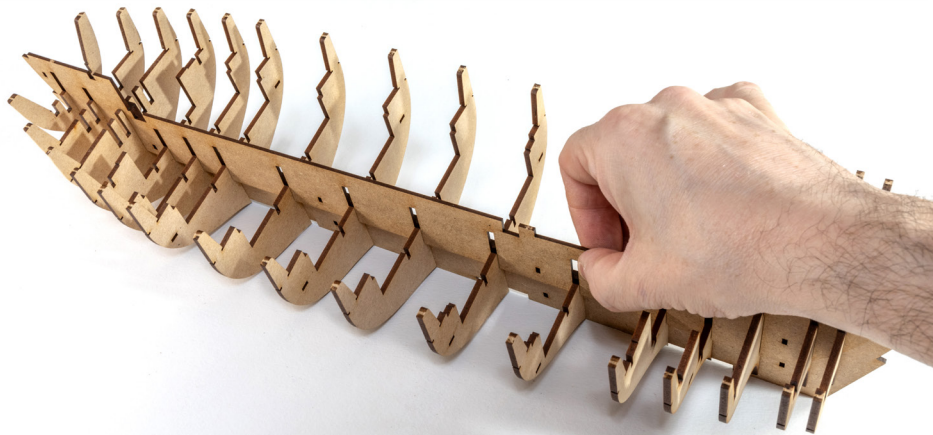

17. From the 2mm MDF sheet, remove parts K1.



18. Push these into the slots in part 22, through the inner keel, and through the same opening on the other side of the hull. **DO NOT GLUE!**

19. From the 2mm MDF sheet, remove both parts 23.

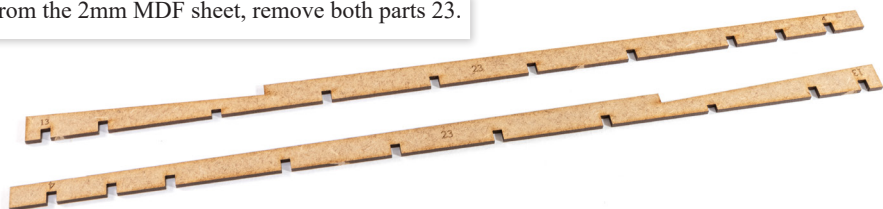

21. Slot these parts into position over the next slot out from the centre of each bulkhead. No force will be needed anywhere, and the parts will easily drop into position. **DO NOT GLUE!** If they don't fit easily, go back and check your previous construction. You can see what the hull will look like with those parts slotted into position.

20. You can see how these are numbered at each end, so denote which bulkhead that slot will fit to.

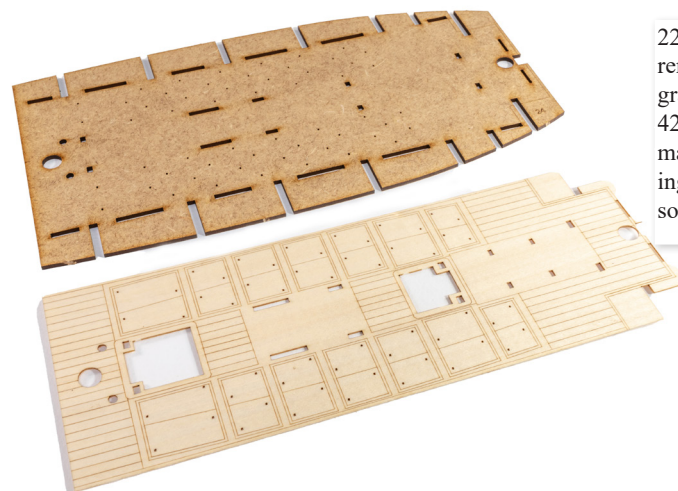

22. From the 2mm MDF sheet, remove part 24. From the engraved deck parts, remove part 42F. There may be some infill material in the various deck openings. You can safely remove that, so it looks as shown here.

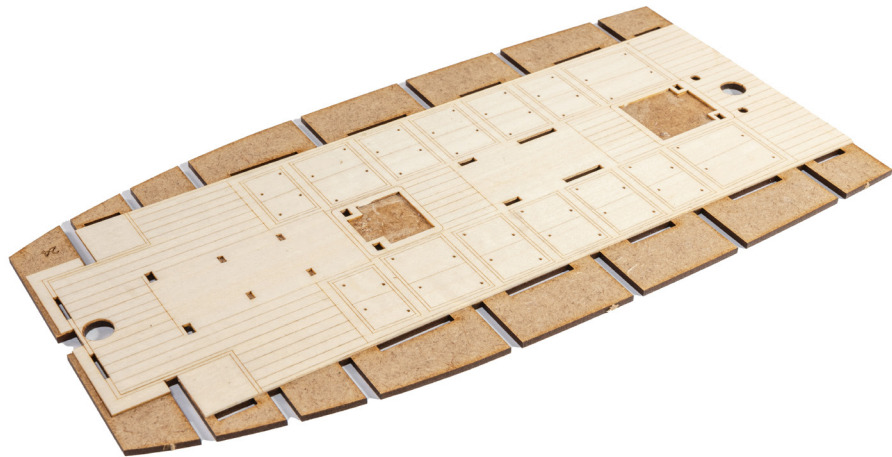

23. The MDF part is engraved with the position on the lime deck, plus you obviously need to line up the various holes. Use wood glue to attach the engraved deck to the MDF and weight the assembly until dry so that the deck won't curl at the edges.

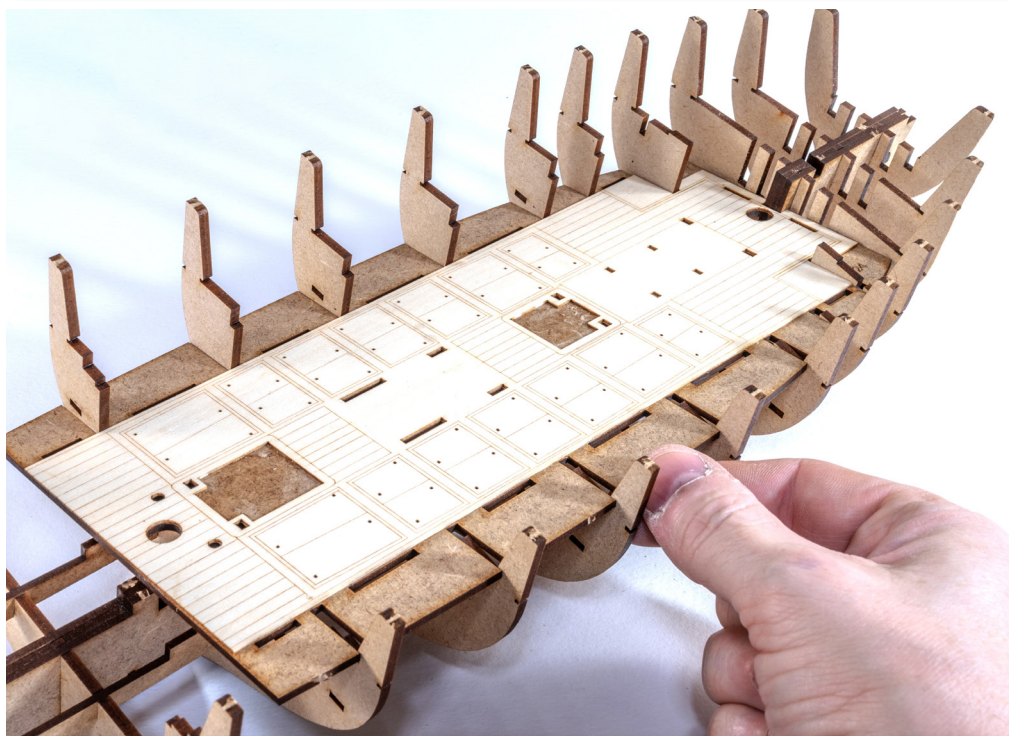

24. Carefully slot the deck section over the bulkheads, at the forward end of the hull. You can see the exact position here. DO NOT GLUE!



25. From the 2mm MDF sheet, remove parts K2.



26. Push the parts through the bulkheads as shown here. This will lock the deck section in position. DO NOT GLUE!



27. From the 2mm MDF sheet, remove part 25. From the engraved deck parts, remove part 42R.

28. Glue these together in the same manner as the forward deck section which you recently assembled.



29. Carefully slot this deck section into place in the rear area of the hull. DO NOT GLUE!

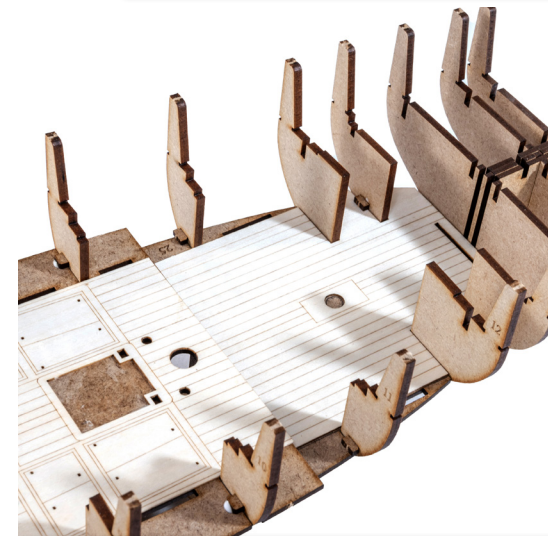

30. This is what the deck should look like when fitted. Use pins K2 to also hold the deck in position. DO NOT GLUE!

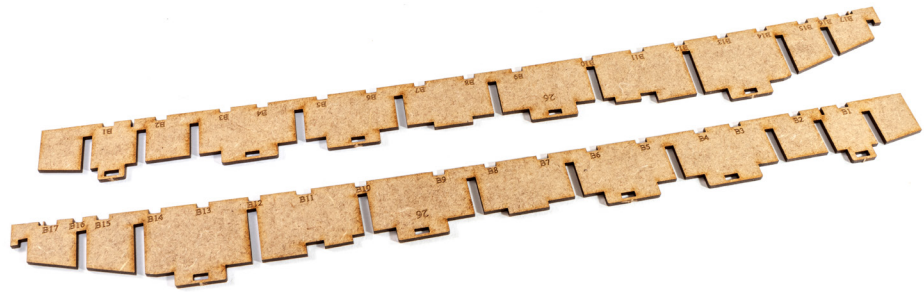

31. From the 2mm MDF sheet, remove both parts 26. Note how these are engraved with the numbers for the deck beams which will sit in those positions. The end of the part which has 'B17' engraved, denotes the rear of the parts, which will sit at the stern end. These engraved sides must face the outside of the hull when fitted, so you will later be able to read those numbers.

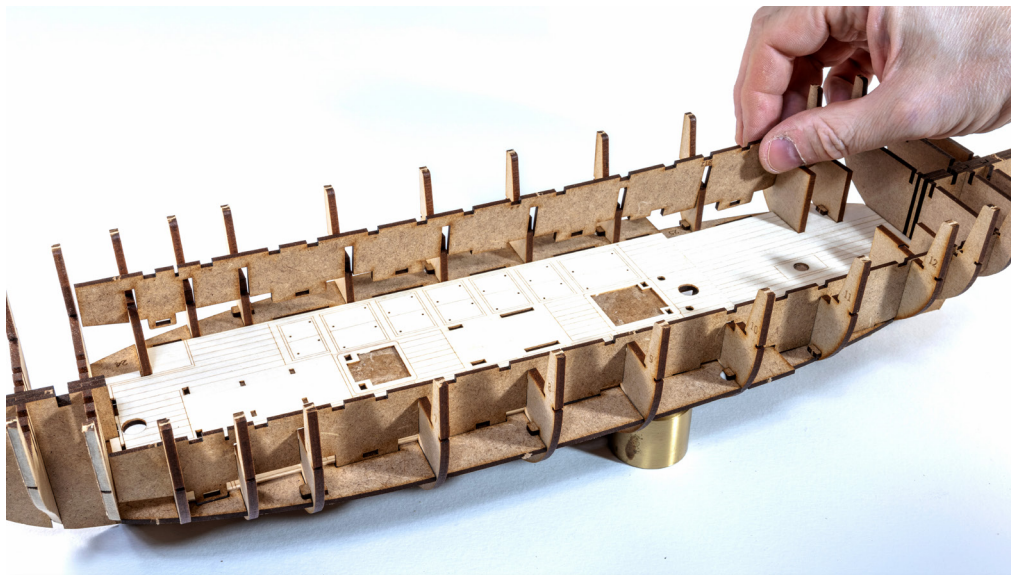
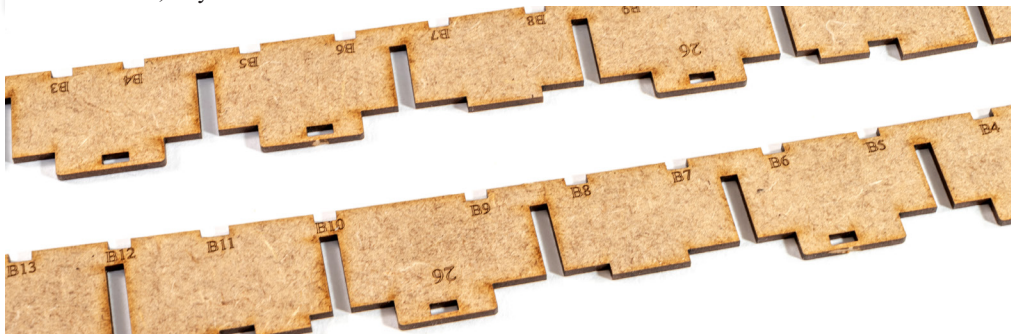

32. Slot both parts into place, so the slots sit on the bulkheads, and the lower tabs protrude through the lower deck section. **DO NOT GLUE!**

33. Here you can see how those parts look when fitted.

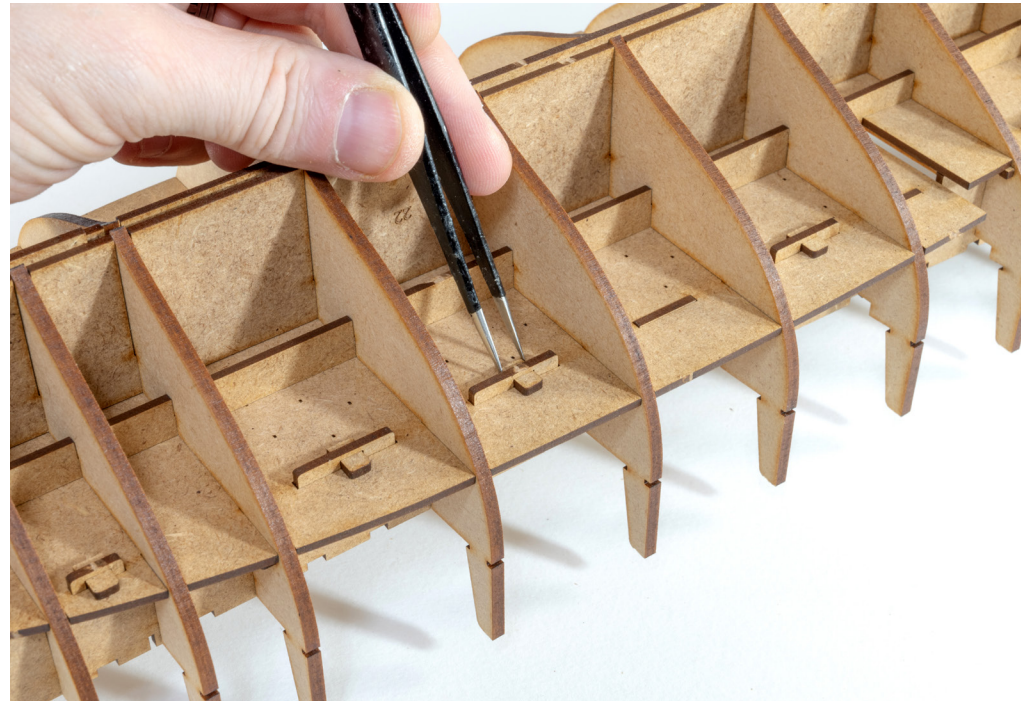
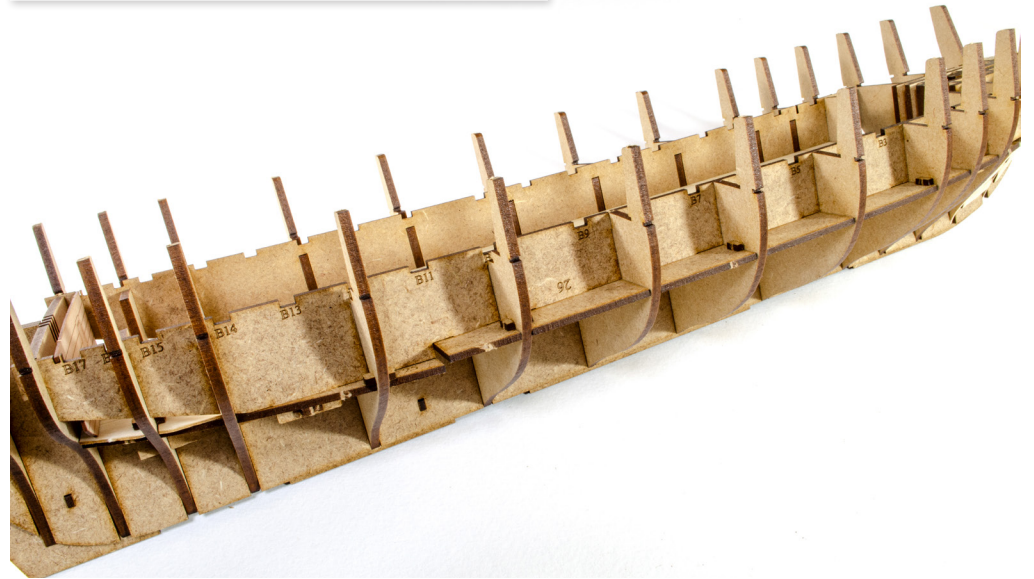

34. Use pegs K2 to lock those parts into place from the underside of the deck. **DO NOT GLUE!**

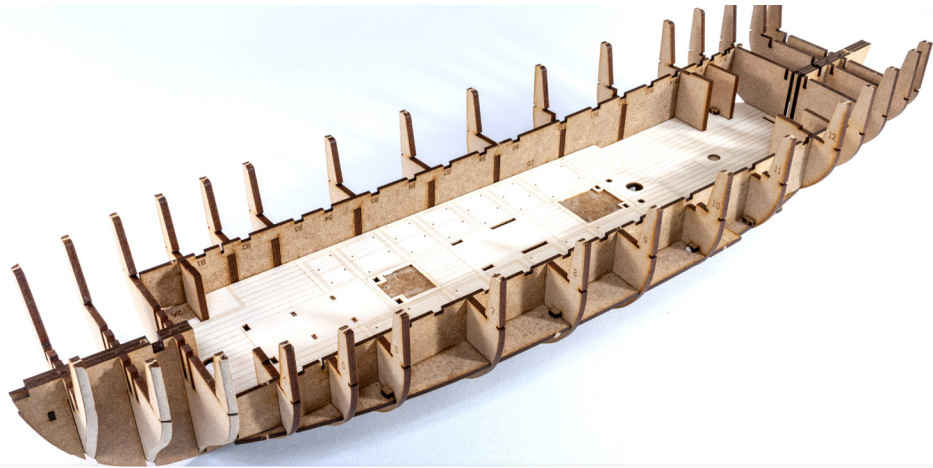

35. HMS Harpy will now look like this. Make sure that everything is seated correctly and that all bulkheads etc. are in place. It's a good idea at this stage to put a steel ruler or similar along the lower inner keel, making sure that nothing is warped. Look down the hull from bow to stern. Does everything look aligned and even? If not, disassemble the hull until you find the issue. If all looks good, we can progress to the next important step.

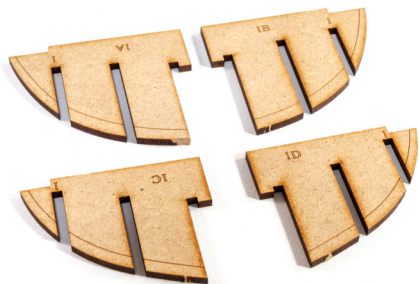

36. From the 3mm MDF sheet, remove parts 1A, 1B, 1C, and 1D. As per the three bulkheads you have already installed, these parts also need to be bevelled.

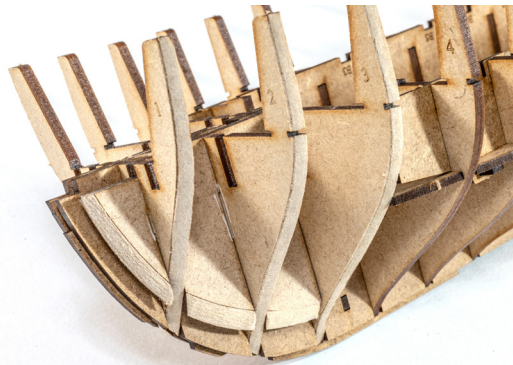

37. Part 1A fits as shown here, across the innermost slots on the first three bulkheads. These new parts can be glued into position.



38. Part 1C now fits into the next slot adjacent to Part 1A.



39. Part 1B can now be glued in the opposite side of the hull, in the innermost slots over the first three bulkheads, as per Part 1A.



40. Part 1D can now be glued into position, outward of Part 1B.

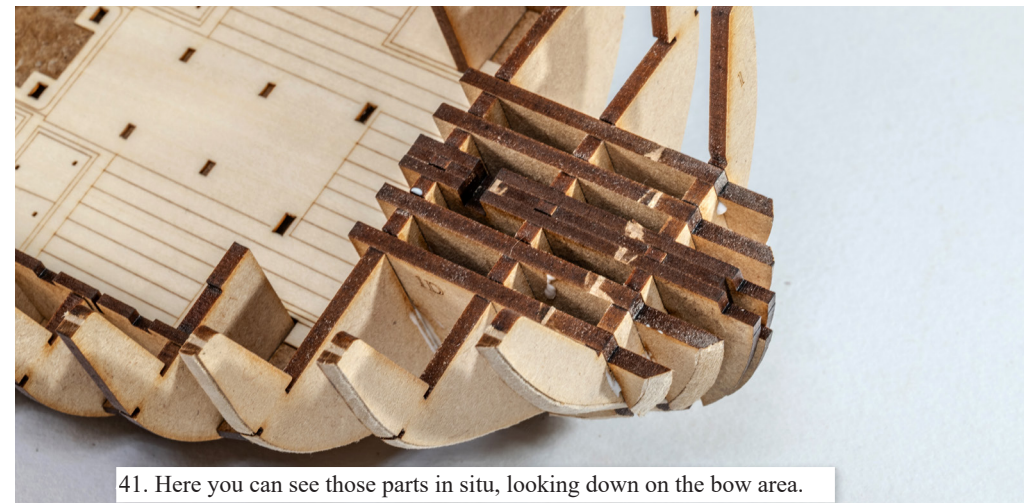

41. Here you can see those parts in situ, looking down on the bow area.

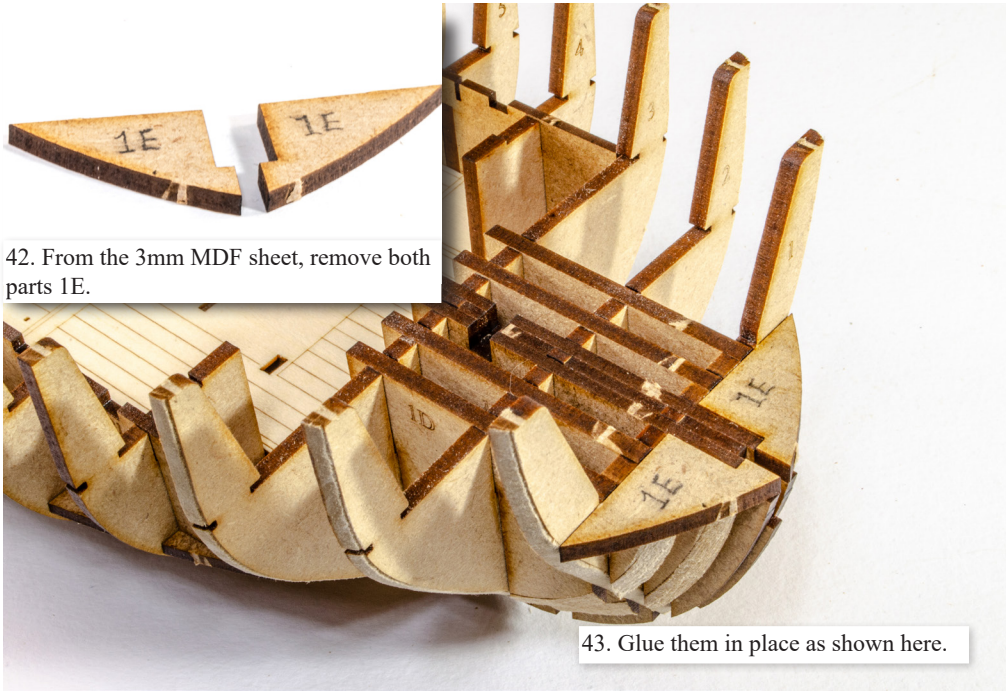

42. From the 3mm MDF sheet, remove both parts 1E.

43. Glue them in place as shown here.

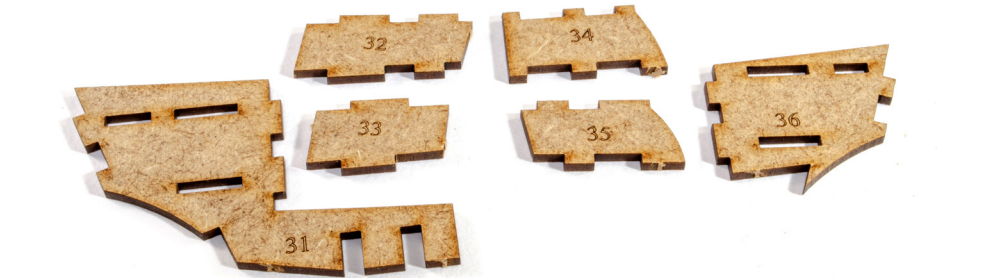

44. From the 2mm MDF sheet, remove parts 31, 32, 33, 34, 35, and 36. These will form the structures at the stern of the ship.



45. Glue parts 32 and 33 onto part 31. Note the orientation, but also that the slots are designed so you cannot get this wrong.



46. Now glue part 36 into place as shown.



47. At the rear of the assembly, glue part 35 in the orientation shown. Again, slots are designed so you can't get this wrong.



48. Now glue part 34 into position.

49. You need to repeat the process with the second set of parts with those numbers but build the assembly so it mirrors the first one, as you can see here.

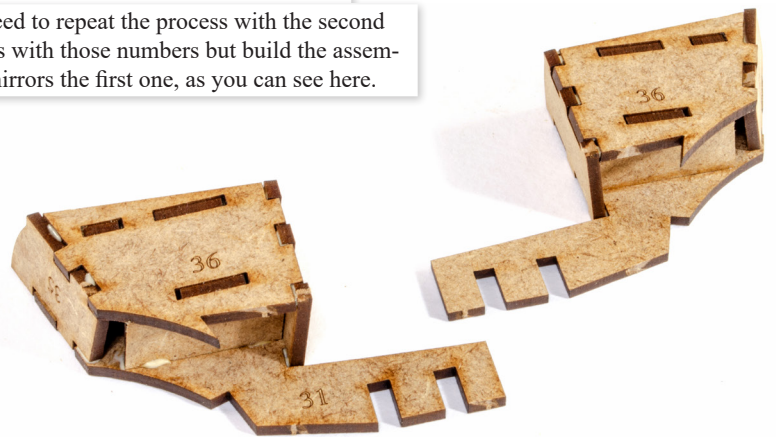

50. From the 2mm MDF sheet, remove both parts 27.



51. Glue them into place at the stern. They fit into the innermost slots, adjacent to the inner keel.

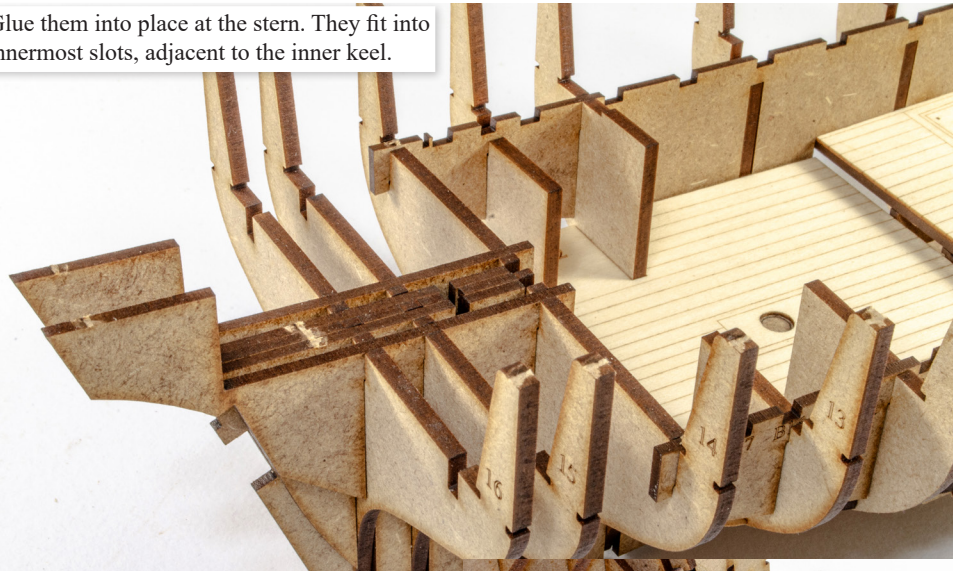

52. Take bulkhead 17, that you removed from the sheet at the start of construction. Bevel it from the engraves line to the back, top edge of the part.



53. This can now be glued into place on the rear of the inner keel, as shown.



54. Now glue the two structures you just built into the slots on bulkheads 15, 16, and 17.



55. As you have already proven that the hull is true and straight, we can now add glue. I use Titebond with a little dilution (but any white glue can also be used), and brush this into all the joints between frames and bulkheads, and pegs etc. Leave this to thoroughly dry before proceeding.



56. From the 1mm wood sheet, remove part 177.

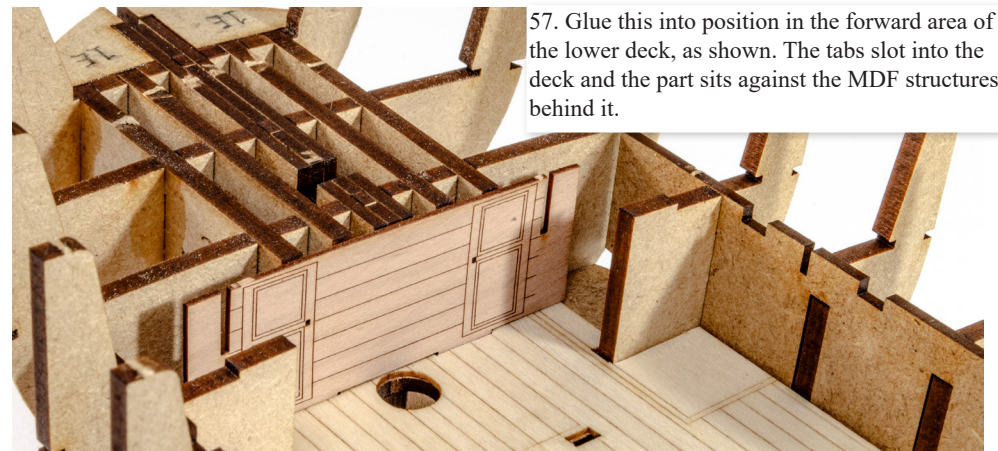

57. Glue this into position in the forward area of the lower deck, as shown. The tabs slot into the deck and the part sits against the MDF structures behind it.

58. Now remove parts 173, 174, 175, and 176, from the same 1mm wood sheet.

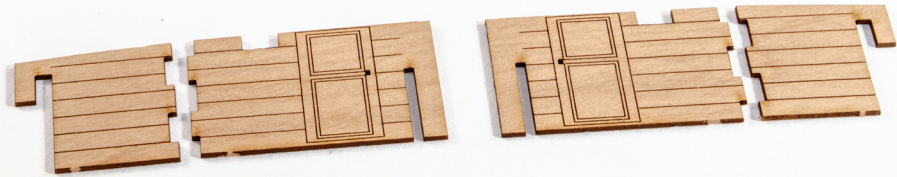

59. Assemble the parts as shown with 174 and 176 making a pair, and 173 and 175 making the opposite pair. Leave to thoroughly dry.

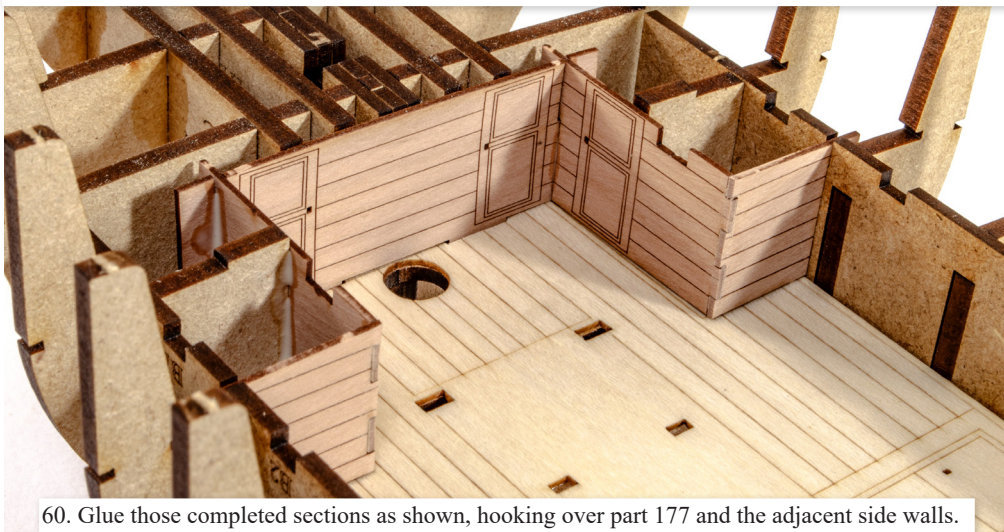

60. Glue those completed sections as shown, hooking over part 177 and the adjacent side walls.

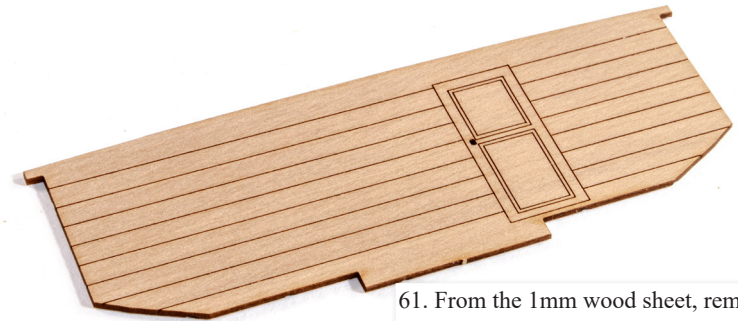

61. From the 1mm wood sheet, remove part 178.



62. Glue into plate at the rear of the lower deck.



63. From the 1mm wood sheet, remove part 172.

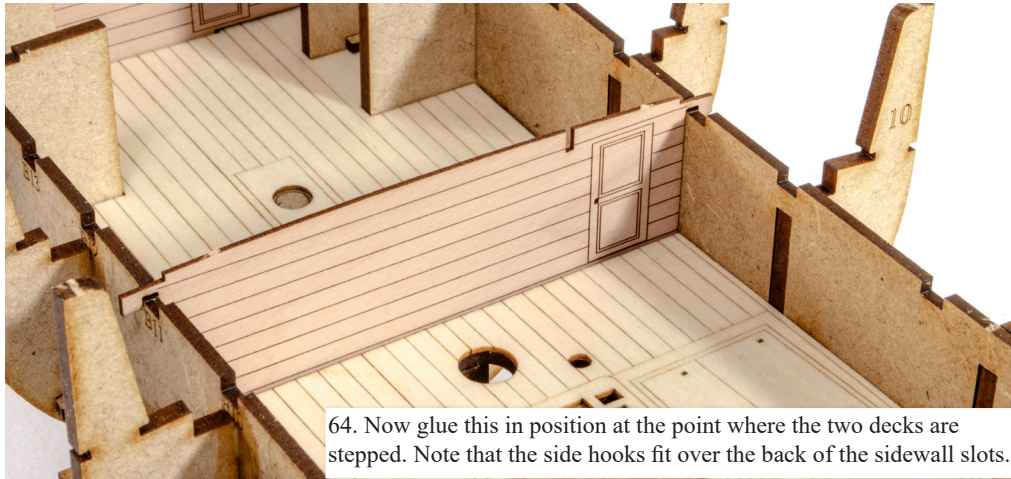

64. Now glue this in position at the point where the two decks are stepped. Note that the side hooks fit over the back of the sidewall slots.

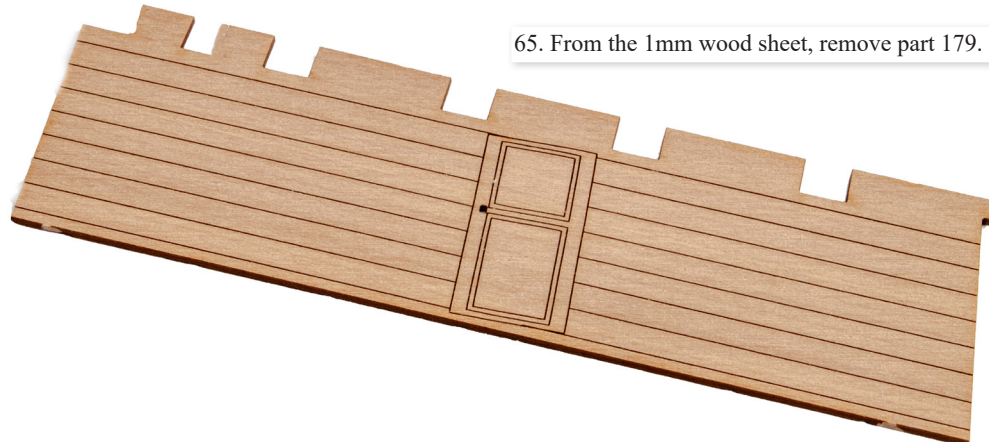

65. From the 1mm wood sheet, remove part 179.

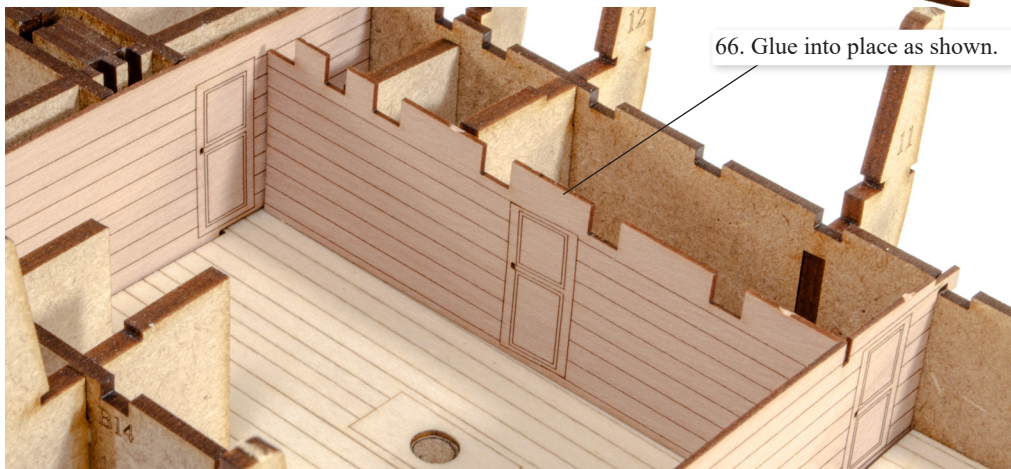

66. Glue into place as shown.

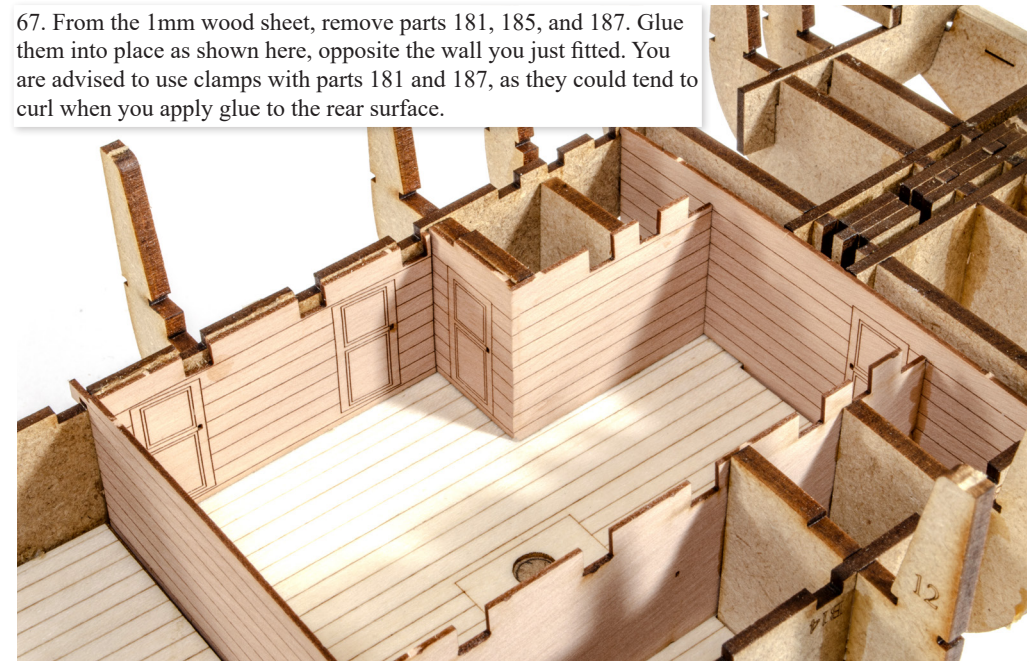

67. From the 1mm wood sheet, remove parts 181, 185, and 187. Glue them into place as shown here, opposite the wall you just fitted. You are advised to use clamps with parts 181 and 187, as they could tend to curl when you apply glue to the rear surface.

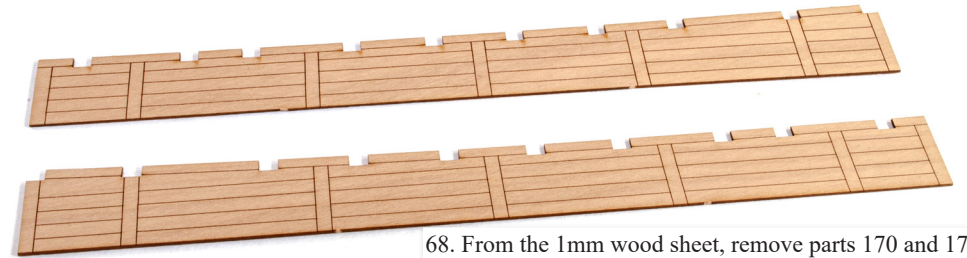

68. From the 1mm wood sheet, remove parts 170 and 171.



69. Glue them into place and clamp to stop the parts curling after glue is applied. Part 171 is the one you see being clamped in this photo, with part 170 on the opposite side.

70. From the 1.5mm wood sheet, remove parts 201 and 202.

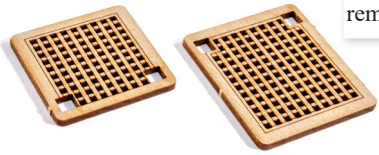

71. Remove the char and clean up the parts before gluing in place on the lower deck. The decks are engraved to denote the precise position of the parts.

72. From the same 1.5mm wood sheet, remove part 197.

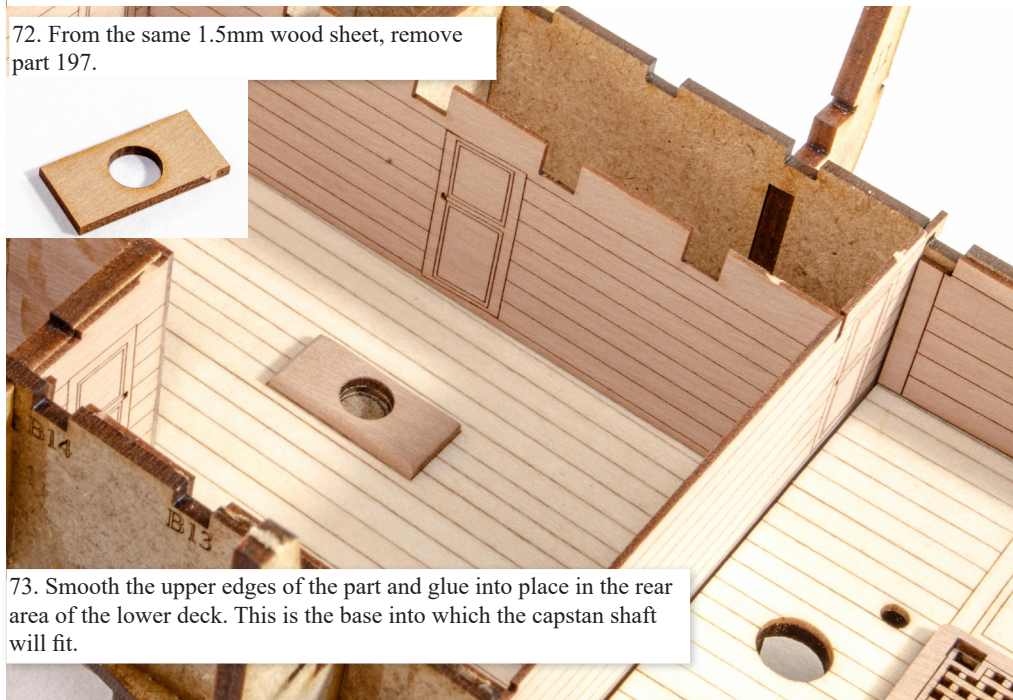

73. Smooth the upper edges of the part and glue into place in the rear area of the lower deck. This is the base into which the capstan shaft will fit.

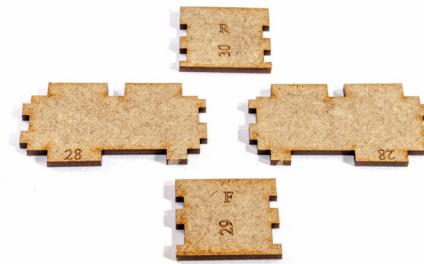

74. From the 2mm MDF sheet, remove parts 28 (x2), 29, and 30.

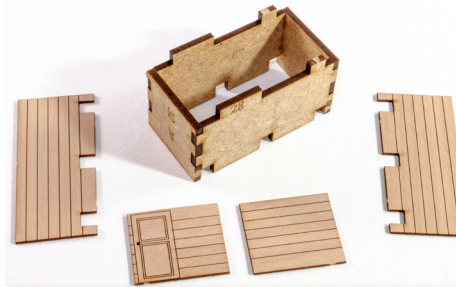

76. From the 1mm wood sheet, remove parts 182, 183, 188, and 189.

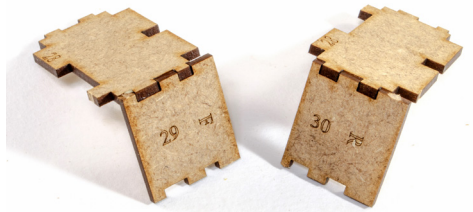

75. These parts only fit one way due to the design of the slots. It's easier to build these in pairs and then when set, glue the halves together.



77. Glue 188 and 189 onto the correct ends of the structure. The part with the door will sit at the front. (Confession is that on my prototype, I got that bit wrong). You can now glue on the wides too. Make sure the notches in the wood and MDF parts are aligned, as this is where the upper deck beams will eventually pass through.

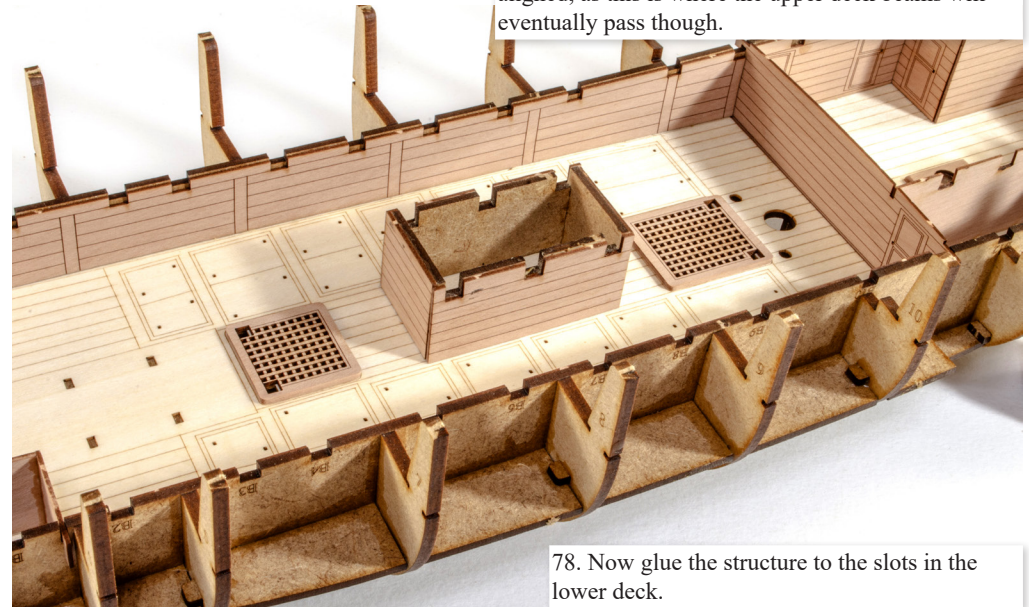

78. Now glue the structure to the slots in the lower deck.

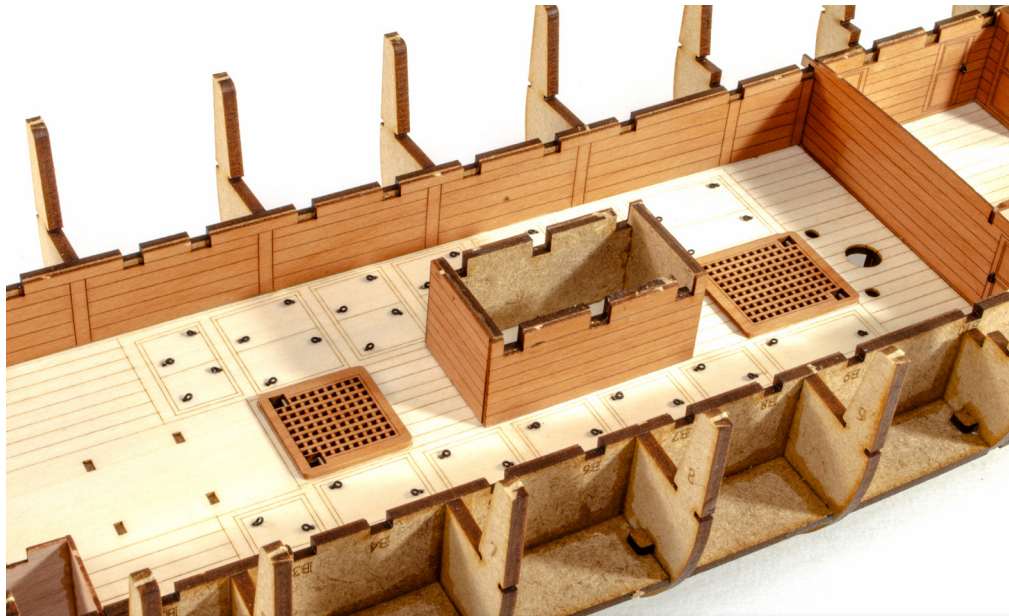

79. At this point, it's worthwhile varnishing the lower deck walls as these will soon be inaccessible. From the 0.4mm photo-etch sheet, paint enough PE-14 eyebolts in black, and bend them to use as door handles and hatch lifting handles. Glue these with superglue.

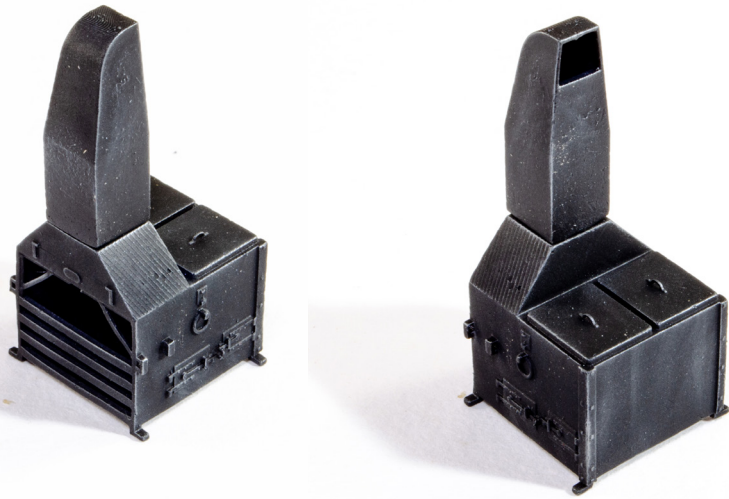

80. Harpy's stove is supplied in two parts. These can now be painted matt black and finished with some metallic pigment, to highlight the details. DO NOT GLUE THESE PARTS TOGETHER! The stove is shown finished for illustration only.

81. The stove body can now be glued in place using superglue. Make sure the stove sits flat on the deck first, and if not, trim any bulge from the underside.

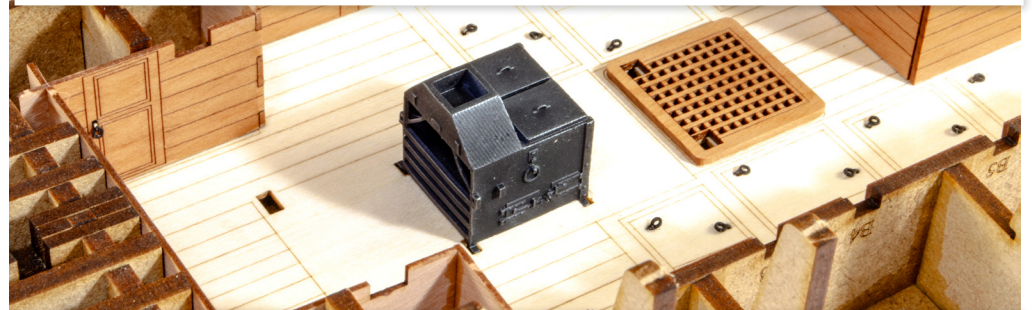

82. From the 4mm wood sheet, remove the upper deck beams B1 through to B17 (not including B16 which will come later). Remove the laser char from the top of each of these beams.

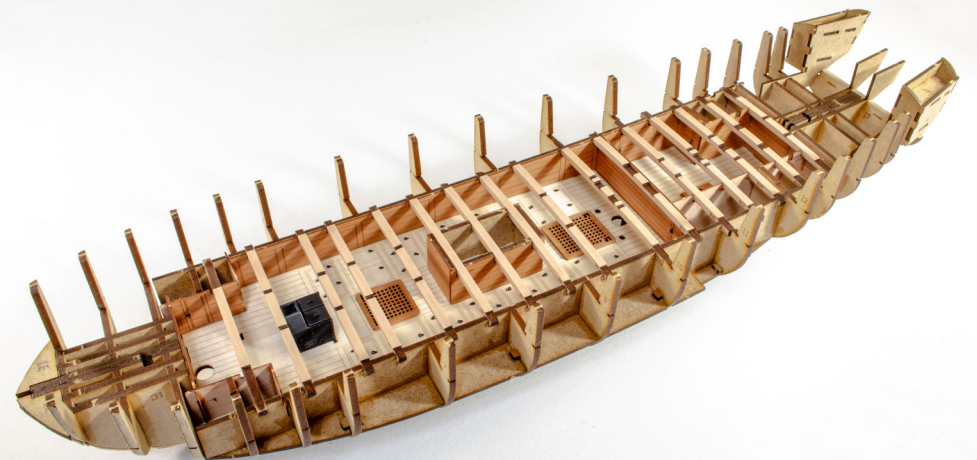
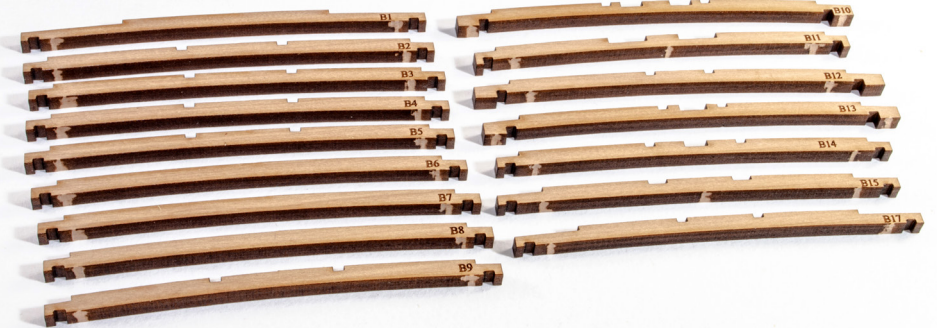

83. Each deck beam can now be glued into the corresponding slots on the sidewalls, using the engraved numbers on the outside, as your reference.

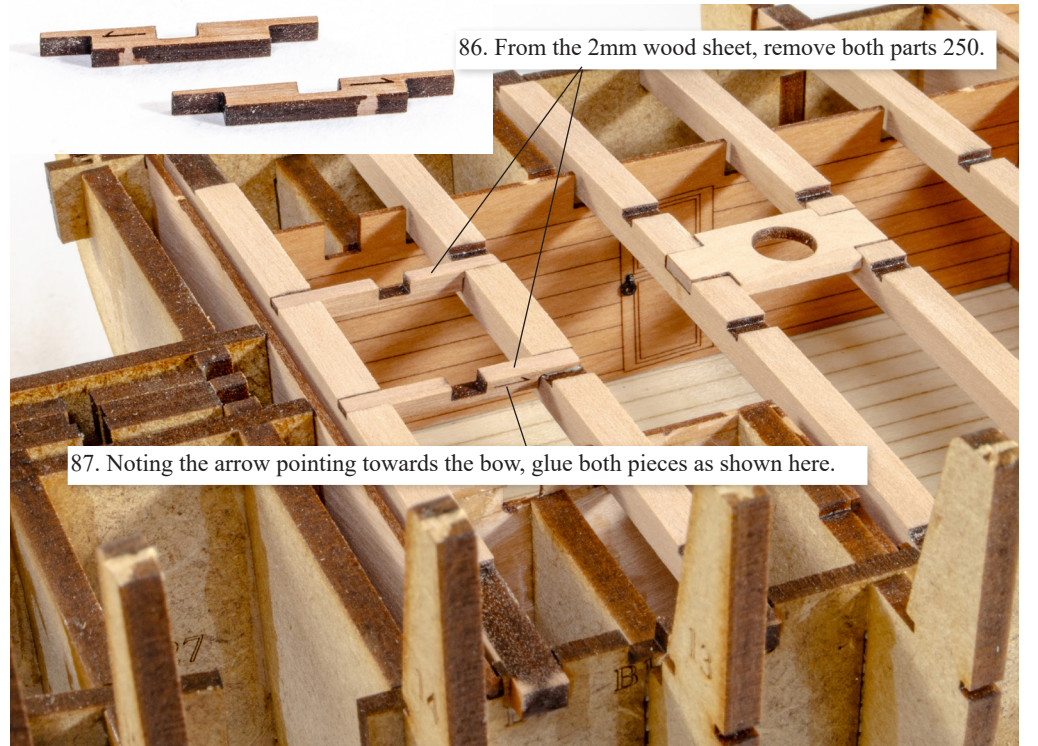
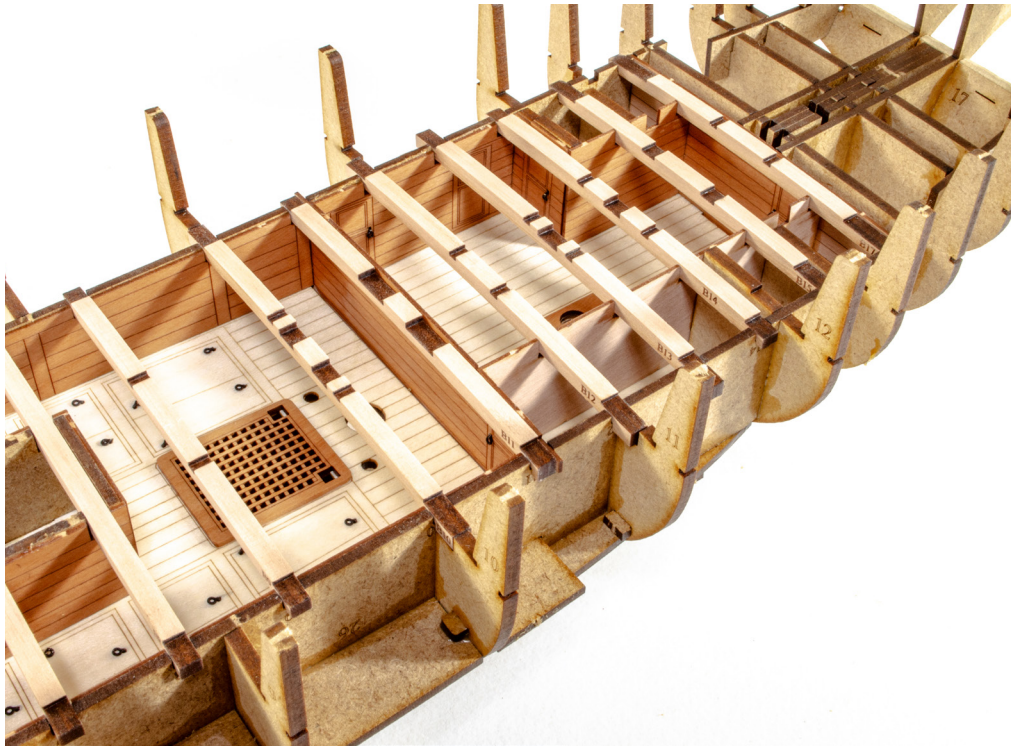
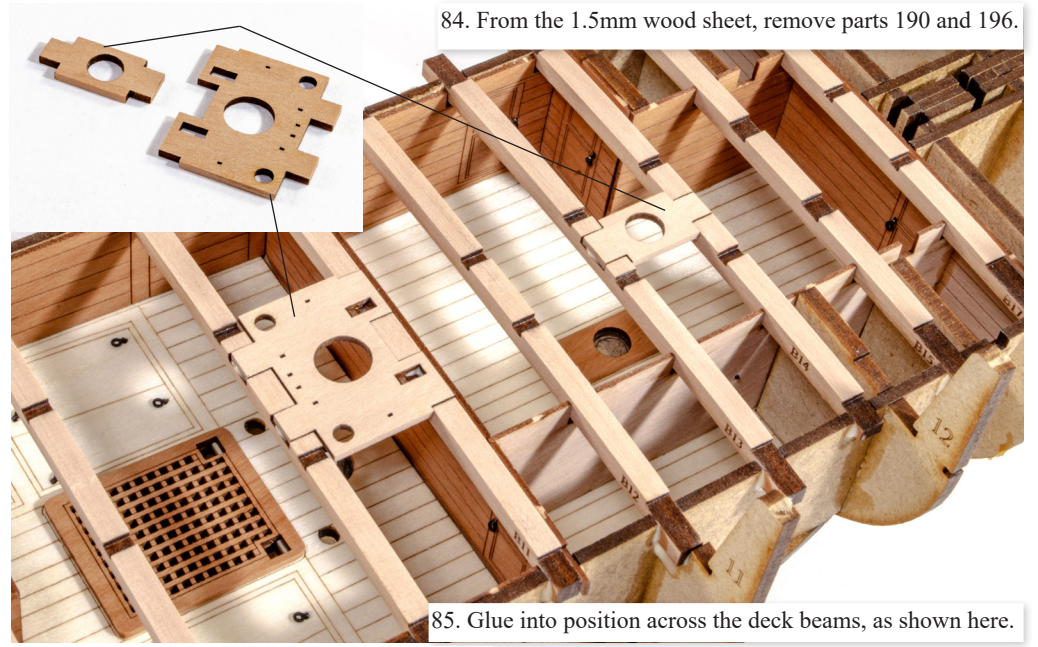
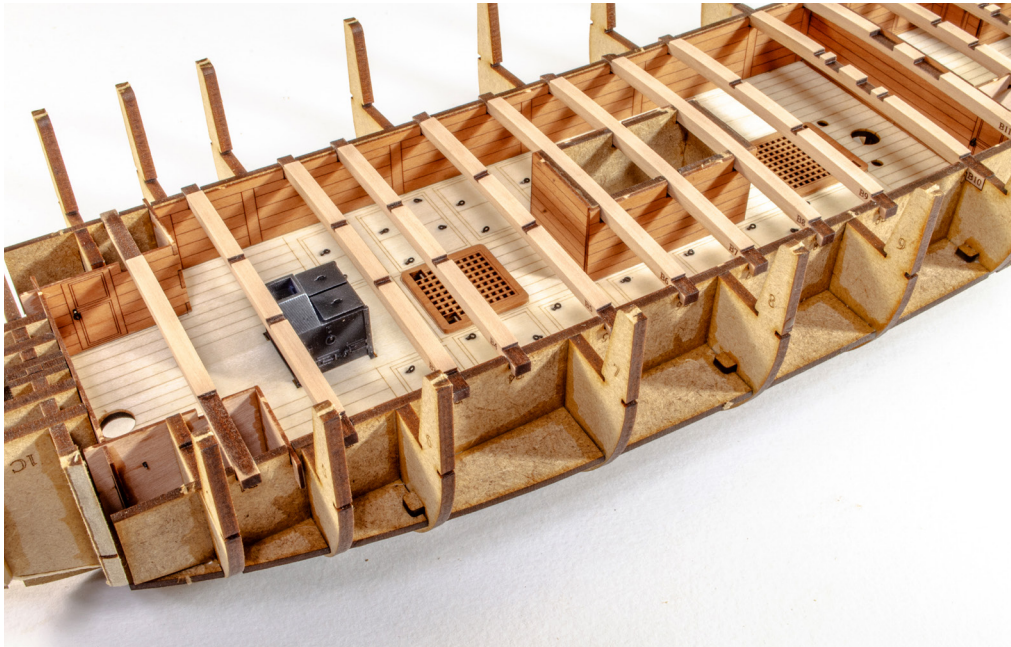

88. From the 3mm wood sheet, remove both parts B16.



89. These are the final deck beams and can be glued into place as shown.

92. From the 2mm wood sheet, remove both parts 248.

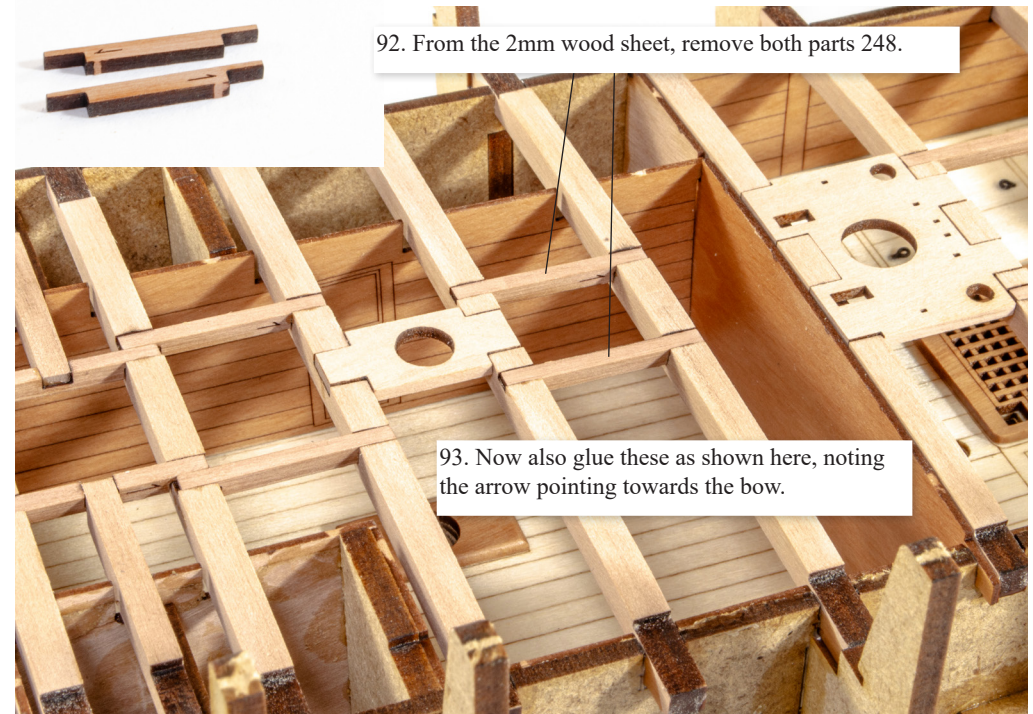

93. Now also glue these as shown here, noting the arrow pointing towards the bow.

90. From the 2mm wood sheet, remove both parts 249.

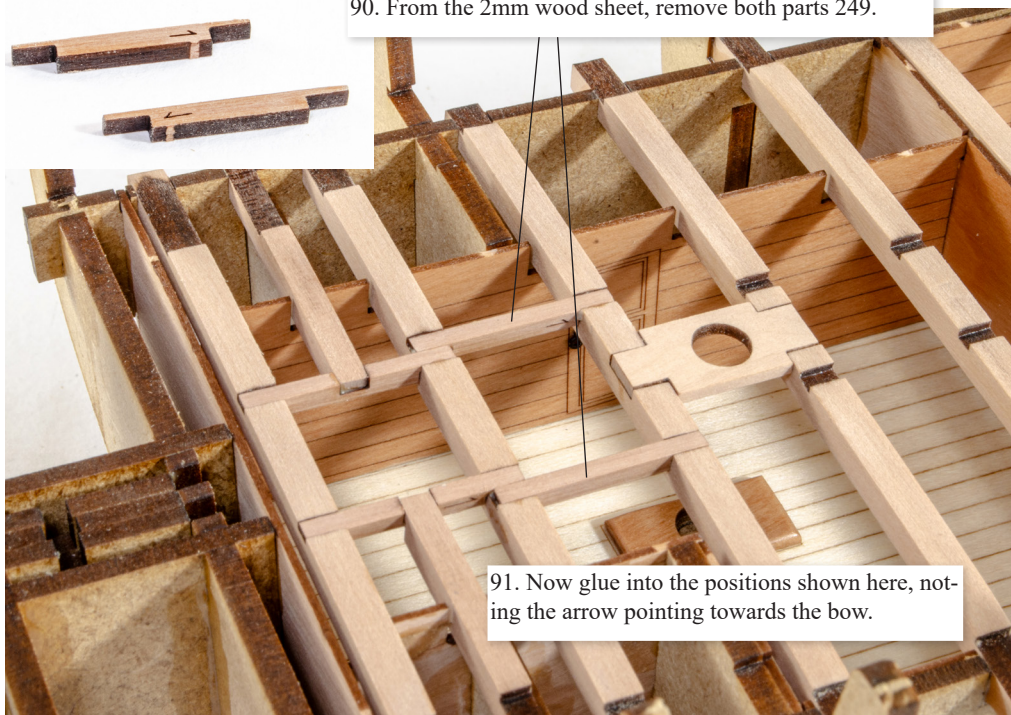

91. Now glue into the positions shown here, noting the arrow pointing towards the bow.

94. From the 2mm wood sheet, remove both parts 247.

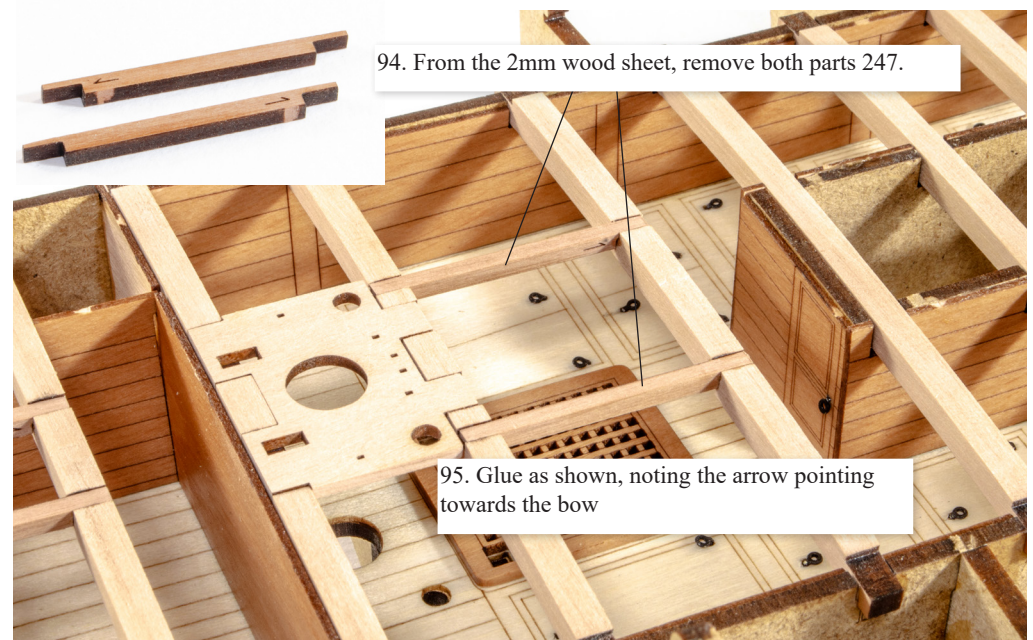

95. Glue as shown, noting the arrow pointing towards the bow

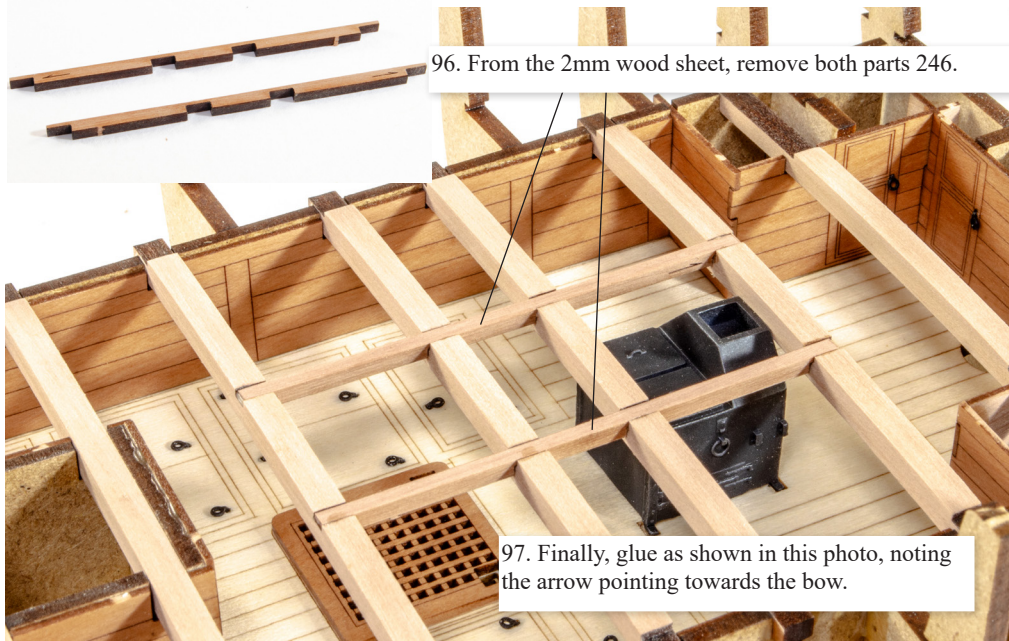

96. From the 2mm wood sheet, remove both parts 246.

97. Finally, glue as shown in this photo, noting the arrow pointing towards the bow.

98. From the 1mm wood sheet, remove both parts 140.

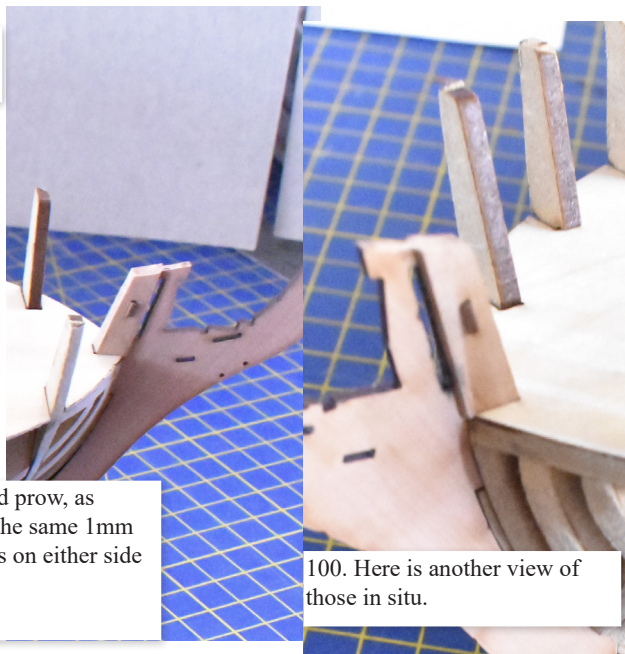

99. Glue these into place on the forward prow, as shown here. Use a wood peg K3 from the same 1mm wood sheet to align and glue these parts on either side of the inner prow.

100. Here is another view of those in situ.

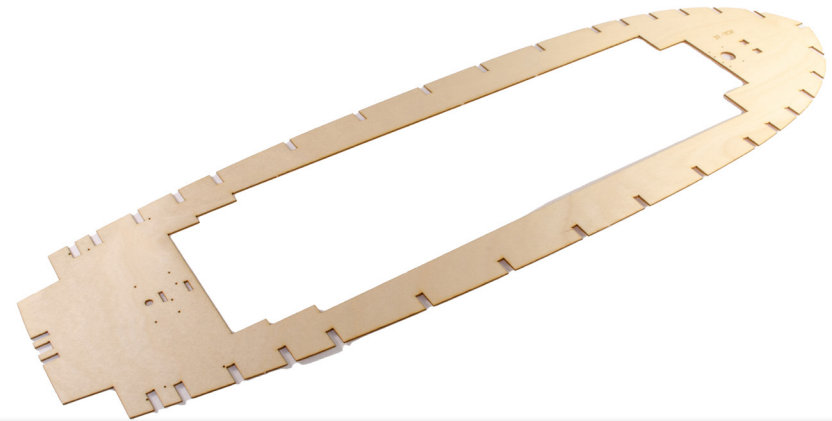

101. With the lower deck complete, we can move upwards. From the 0.8mm ply sheet, remove part 37.

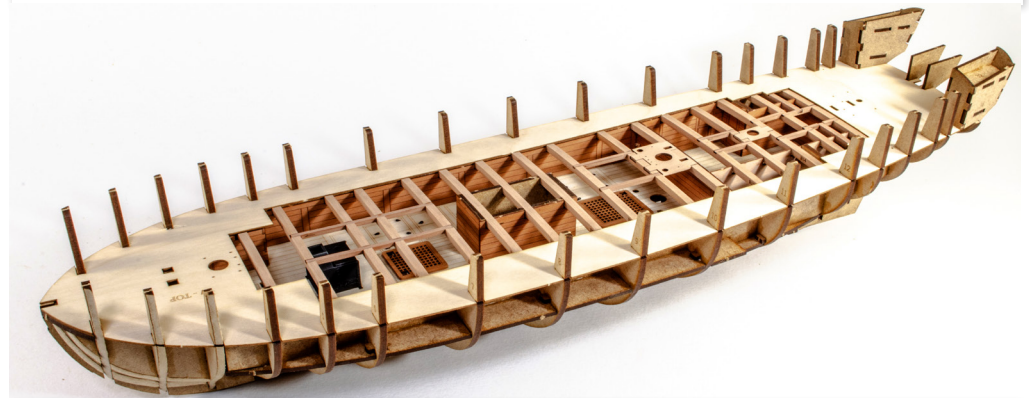

102. This deck now needs to be popped into place. This is very easy and can be done by flexing the deck and hooking it over the bulkhead ears along one side of the hull. As you work the deck downwards so that it locks into the slots at the bottom of those ears, begin to work the opposite side in the same way. The deck should sit in all of those little slots, so if it's not sitting flat the deck, then so around the edges and find the area where the deck isn't slotted in. If correctly slotted, the deck WILL sit perfectly.

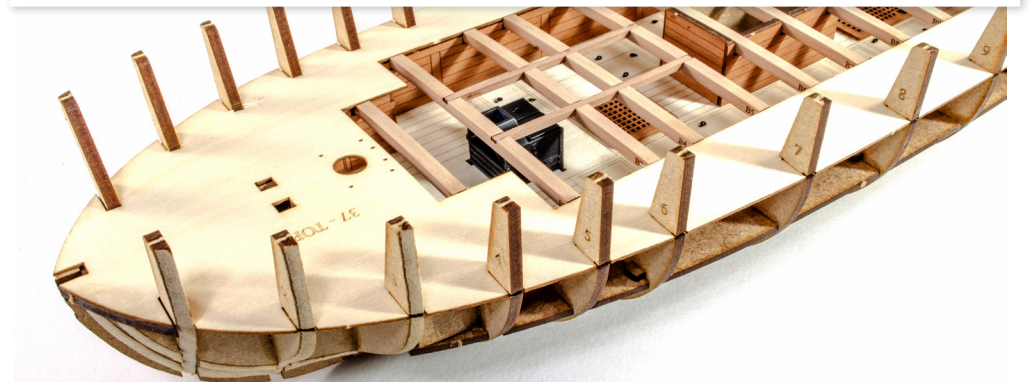

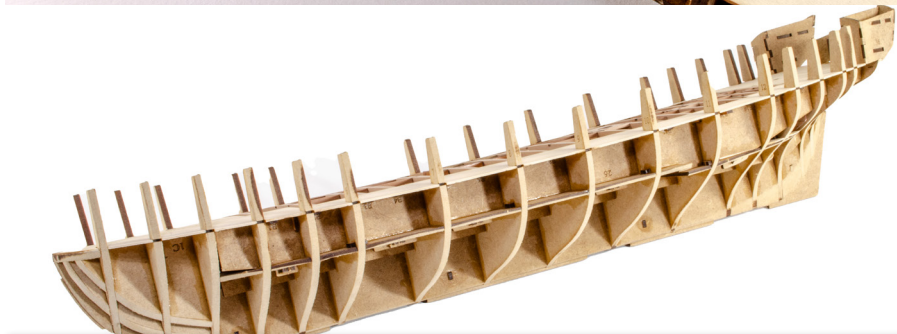
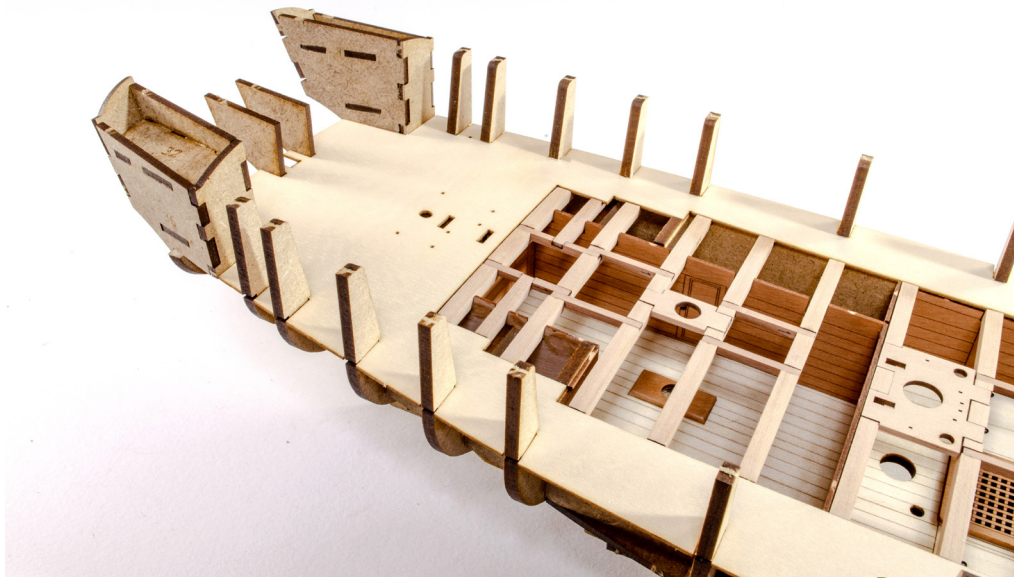

103. You now need to sand the hull so that it runs smoothly from bulkhead to bulkhead. This process is called 'fairing' and you need to take your time with this, using a 1mm lime plank to check that it sits fully on the edge of each bulkhead, as you go. Look down the hull as you lay the test plank, making sure there's no bumps or dips in the flow of the hull's lines.

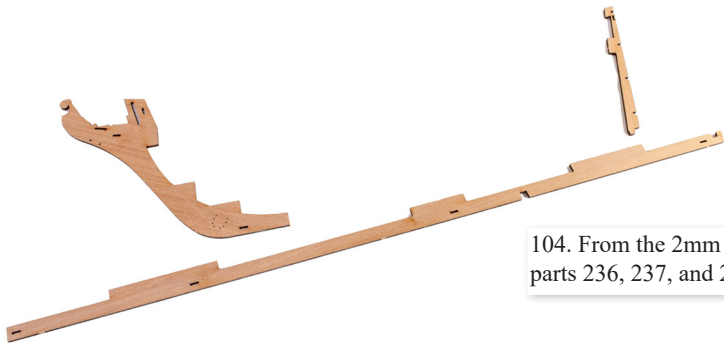

104. From the 2mm wood sheet, remove parts 236, 237, and 238.

105. Glue part 236 into the bow of the hull, as shown here. Leave to thoroughly set.



106. Glue part 238 into place as shown here. Leave to thoroughly set. This post should be perfectly vertical. Leave to set thoroughly.

107. Lastly, test fit and then glue in part 237, and again leave to thoroughly set.

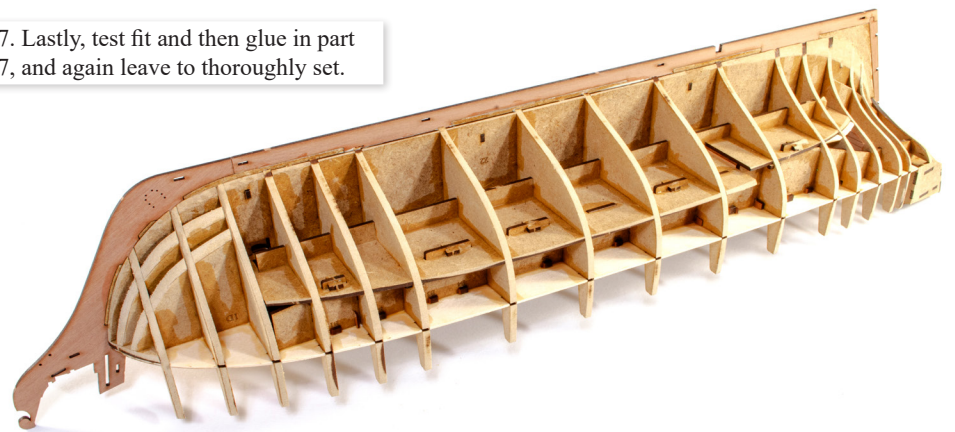

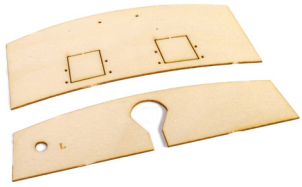

108. From the 0.8mm ply sheet, remove parts 38 and 39. Note that part 38 has a circular hole with 'L' next to it, denoting that the hole must be located on the left side of the hull.

109. Glue this part into place, making sure that it sits centrally so there is an even gap on each side of the rudder post. The bottom edge of this part also needs to sit around the small laser lines on bulkhead #17. You don't need to soak this part to curve it. Instead, you can gently score the underside of it so that it will bend more easily.

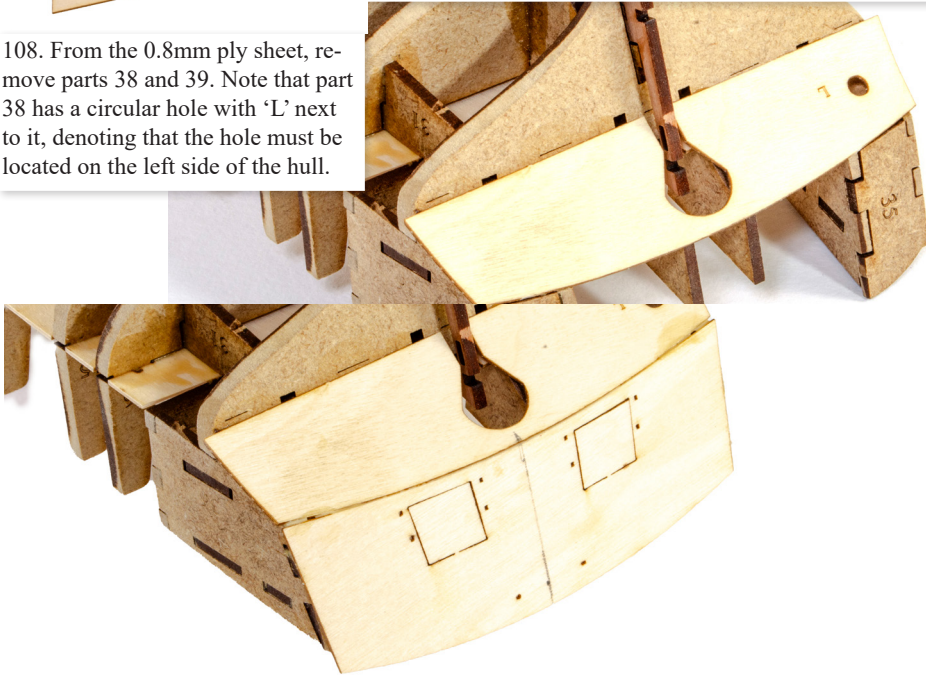

110. Now also glue part 39 into place. It's useful to draw a centreline on this and on the part that you just fitted, so ensure that they align perfectly on the hull, and with each other. Consider slightly bevelling the lower edge of part 39 so it has maximum contact with the lower part 38.



111. When the glue is totally set on those parts, use a sanding block to flush them to the sides of the hull. You can see how the width of bulkhead #17 is also sanded flush and shaped too.

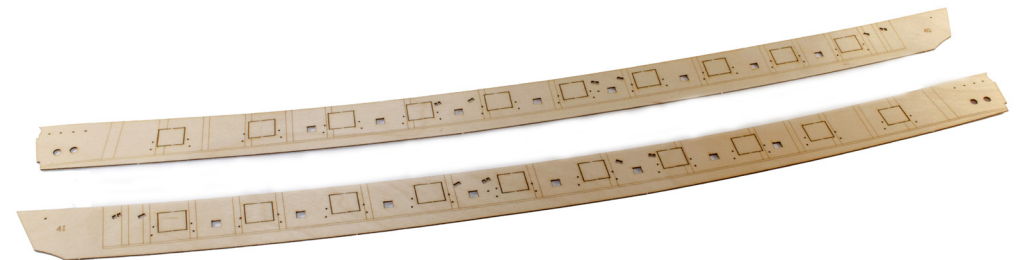

112. From the 0.8mm wood sheet, remove parts 40 and 41. Please note the engraved sides MUST go on the inside of the hull as they denote the deck height positions and close approximations of where the bulkhead ears will sit.

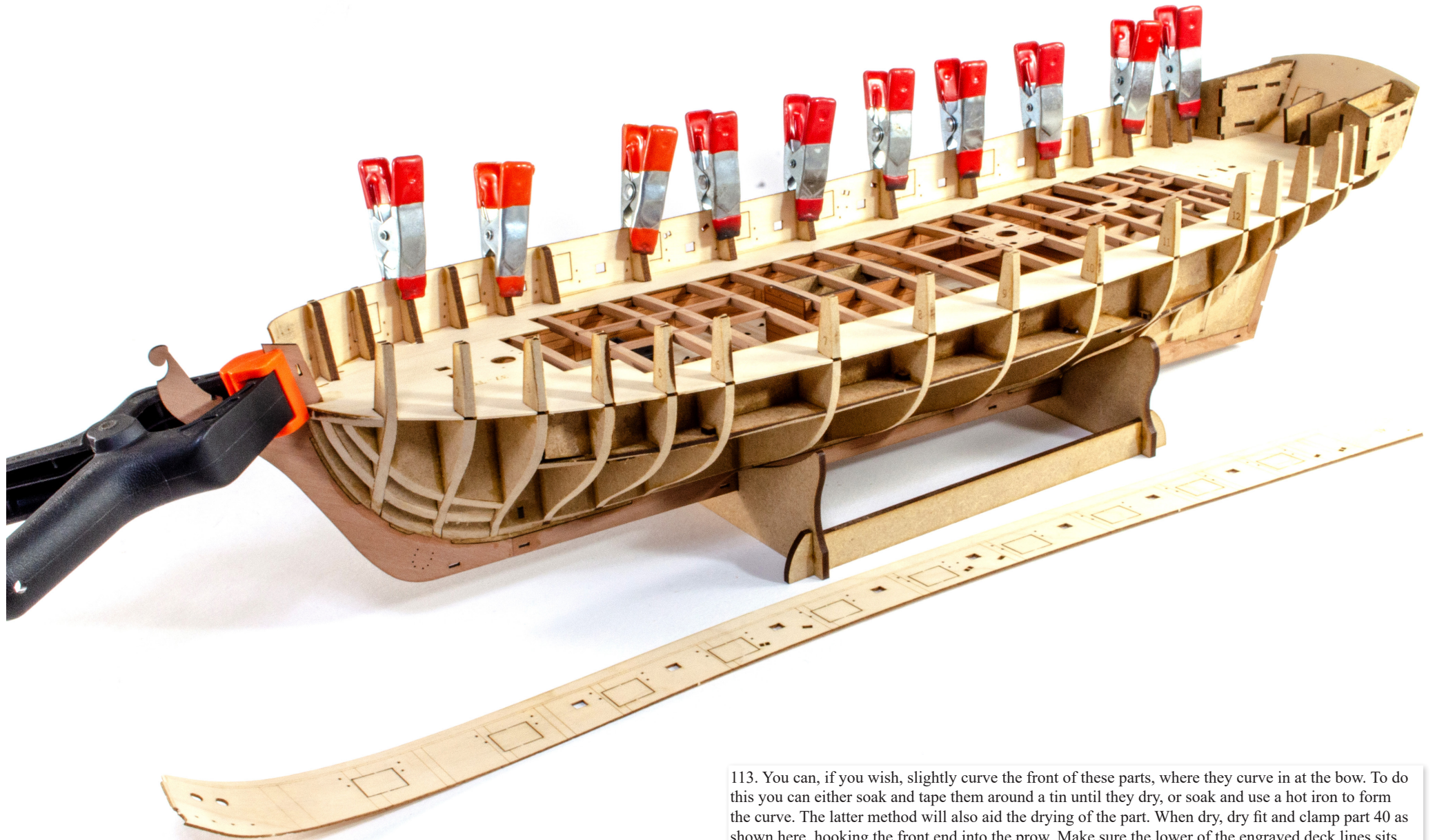

113. You can, if you wish, slightly curve the front of these parts, where they curve in at the bow. To do this you can either soak and tape them around a tin until they dry, or soak and use a hot iron to form the curve. The latter method will also aid the drying of the part. When dry, dry fit and clamp part 40 as shown here, hooking the front end into the prow. Make sure the lower of the engraved deck lines sits flush with the actual ply deck line. If you need to, use brass pins to tack into place. When you're happy with the position, brush glue into the underside joints and leave to dry.

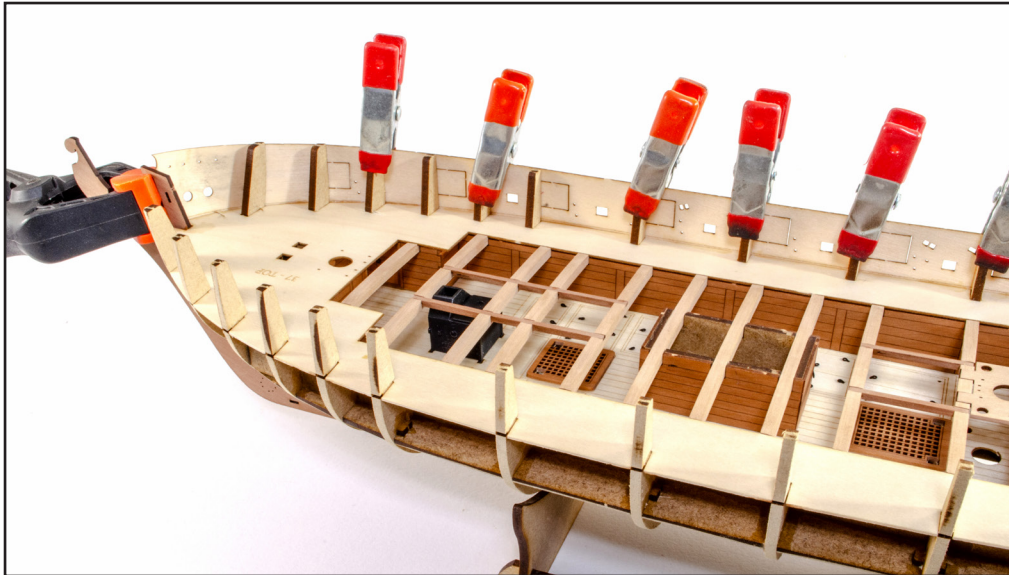

114. Now glue part 41 into place, in the same manner. When they are dry, if there is any overhang at the stern, sand this flush with the stern.



115. We now need to plank the hull with the first layer of 5mm x 1mm lime planks. To do this, hold your first plank under the ply bulwarks, and where it overlaps the bulwarks, running towards the bow, make a pencil mark on the plank. At the front end of the plank, bevel the plank slightly to match the angle at the bow, and then mark the front around $\frac{1}{2}$ to $\frac{1}{3}$ down from the top of the plank. Join the pencil marks together and then cut down the line to remove the scrap part.



116. You can, if needed, use a plank nipper on the inside of the plank, towards the front, to induce a curve. You are advised to also very slightly bevel the top edge of the plank in the forward portion. This will help the plank sit cleanly against the ply bulwark. This is the same for every subsequent plank you fit.



117. Again, if you feel the need to slightly curve the planks, whether at the bow or stern, nipping them on the inside is a nice and easy way to do this.



119. Here you can see the plank at the stern. The excess can be trimmed off later.

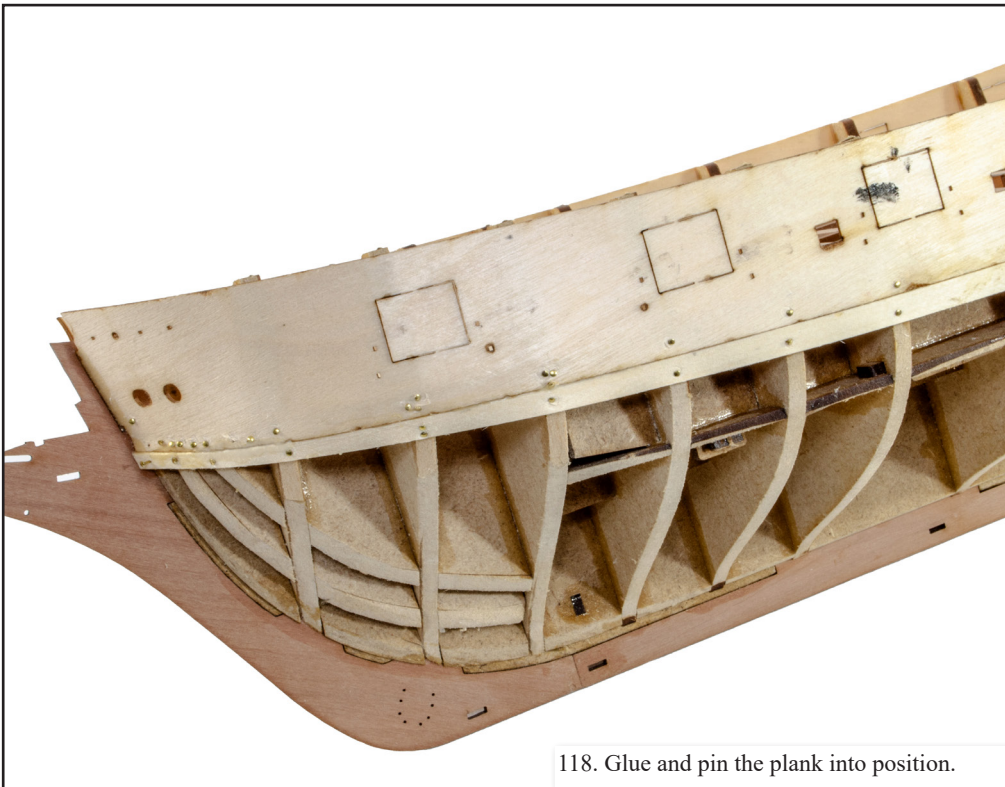

118. Glue and pin the plank into position.



120. You will be able to run many planks down towards the lower keel, in the same way. You may also have your own preferred way of planking. As you approach the keel, you will need to add a plank along that edge. This is called the 'garboard plank'. Feel free to add this in two parts if you feel happier. When fitted, continue to plank down towards the garboard plank. If you have small gaps in your planking, then use scrap limewood to make 'stealers' and fill in those gaps.

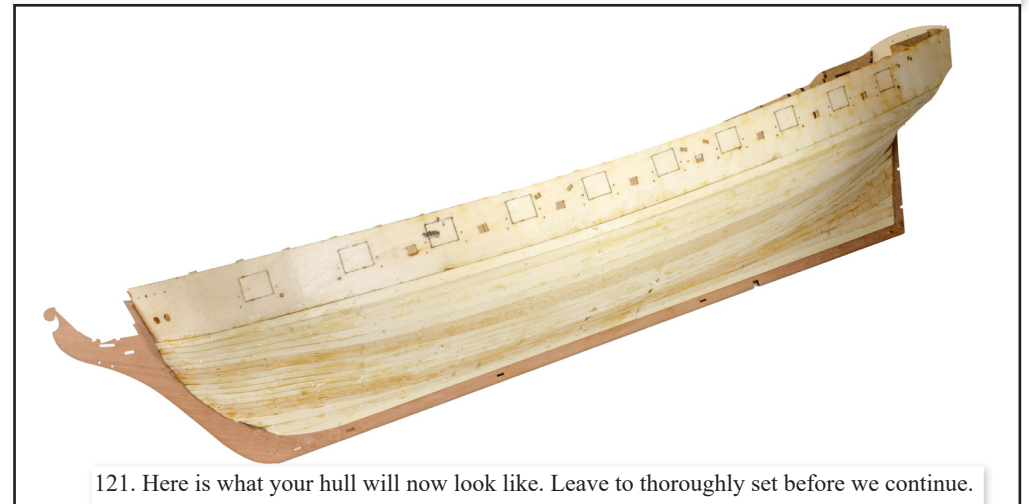

121. Here is what your hull will now look like. Leave to thoroughly set before we continue.



122. You will now need to sand the hull smooth. You can use various tools to do this, such as sanding block, sanding sticks, sanding mouse, or just sandpaper. A combination of any of them also works. This isn't a difficult task, and a good tip is you can 'see' as much with your fingers as with your eyes, with just touch. The planks at the stern also need to be gently feathered so they end up being the same thickness as the stern post. You can protect the stern post by covering in tape before sanding. This will let you know if you accidentally start to stray into that area with your sanding.

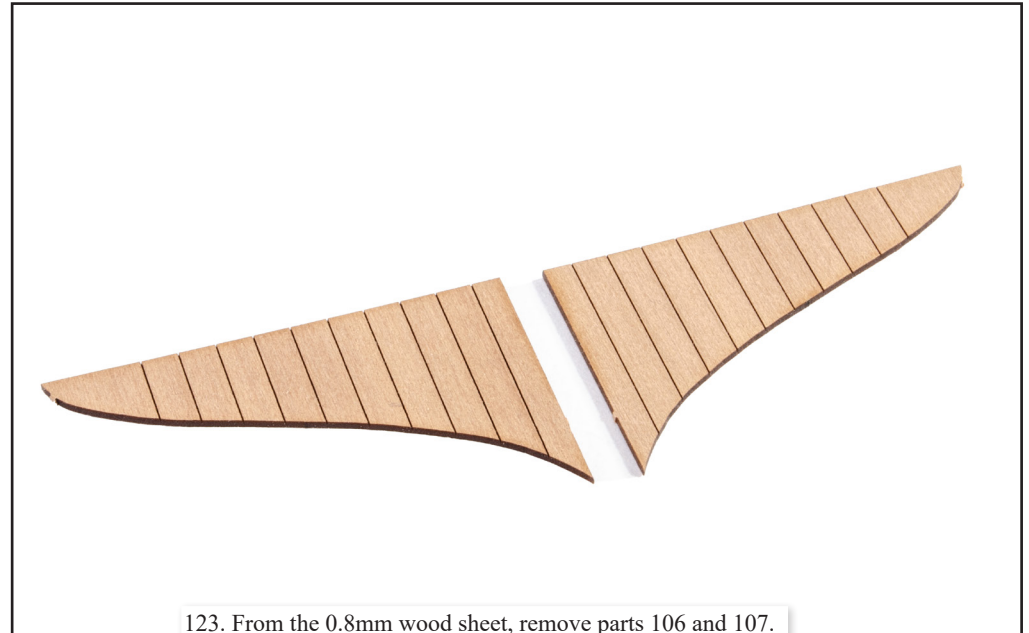

123. From the 0.8mm wood sheet, remove parts 106 and 107.



124. Glue them in situ as shown. The curved edges will sit slightly raised above the hull planking. If not, then sand a little more in that area before fitting these parts.

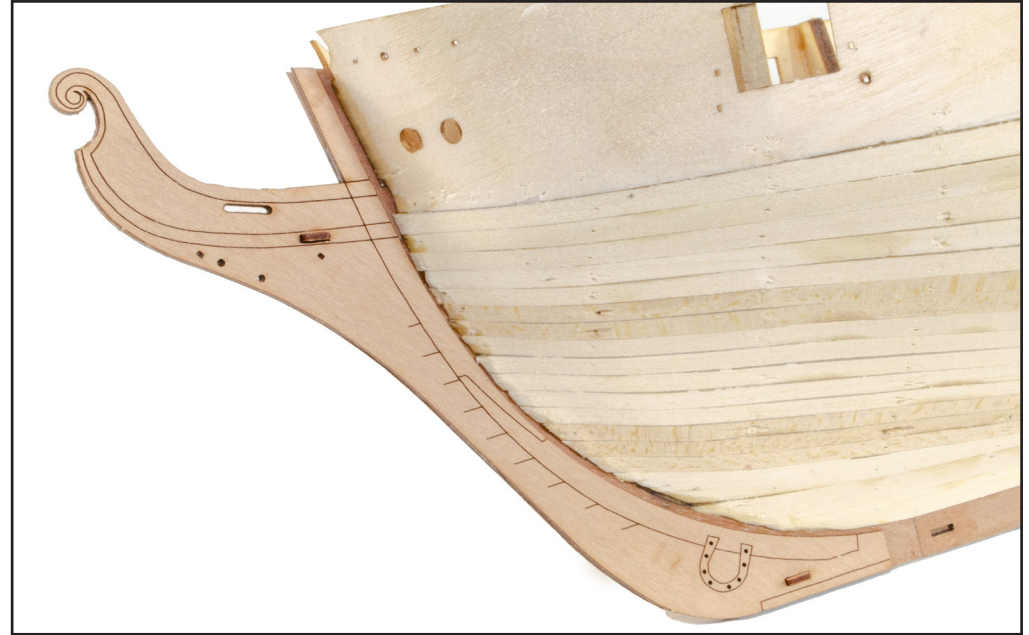

126. Glue part 135 as shown, ensuring perfect alignment. You can use the pegs to help with alignment. When set, glue part 136 to the opposite side of the prow.



125. From the 1mm wood sheet, remove parts 135 and 136. You will also need two pegs K3, from the same sheet.

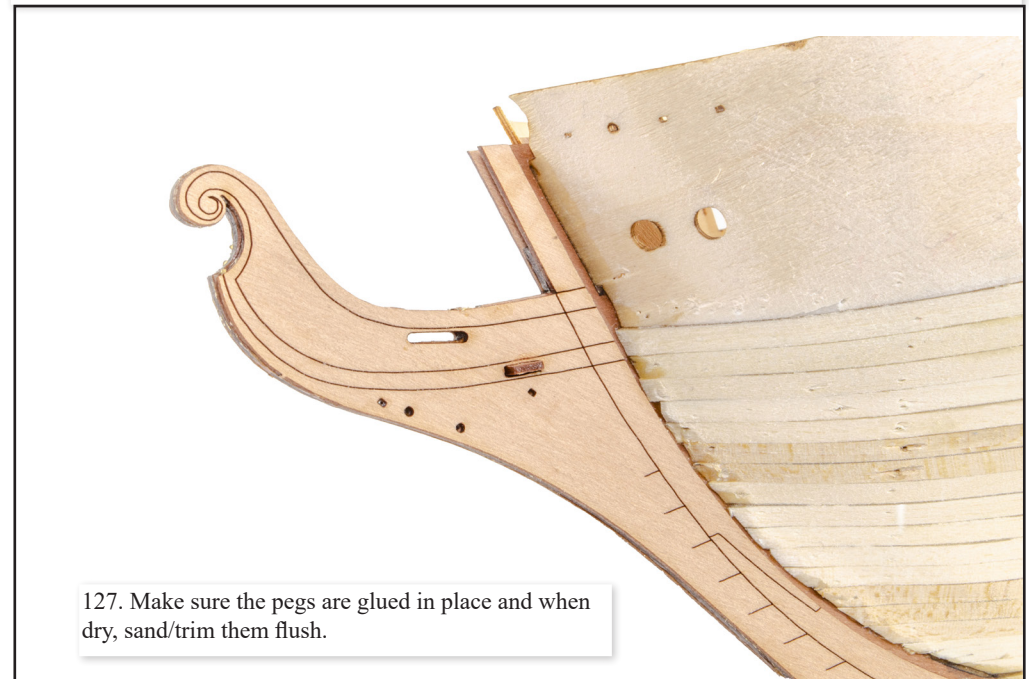

127. Make sure the pegs are glued in place and when dry, sand/trim them flush.

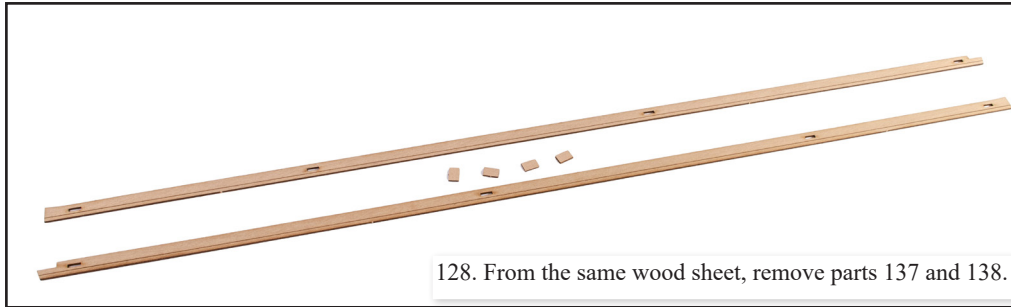

128. From the same wood sheet, remove parts 137 and 138.

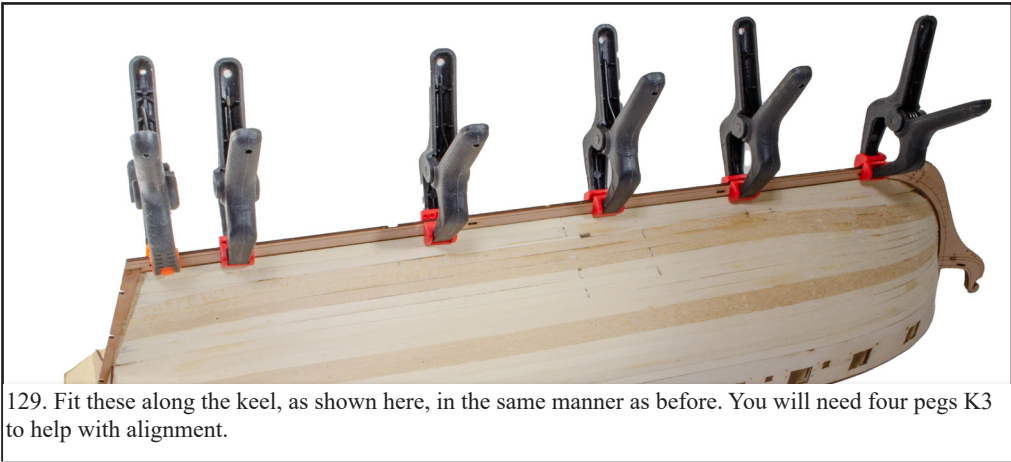

129. Fit these along the keel, as shown here, in the same manner as before. You will need four pegs K3 to help with alignment.

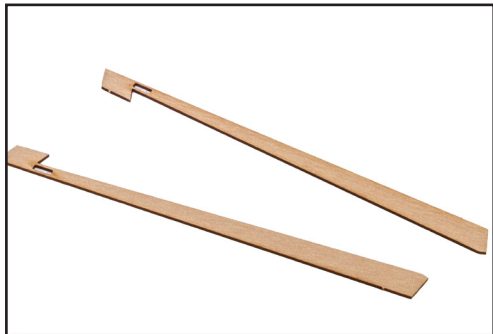

130. From the same wood sheet, remove both parts 139. These have no engravings on them, so they can be used either side of the rudder post.

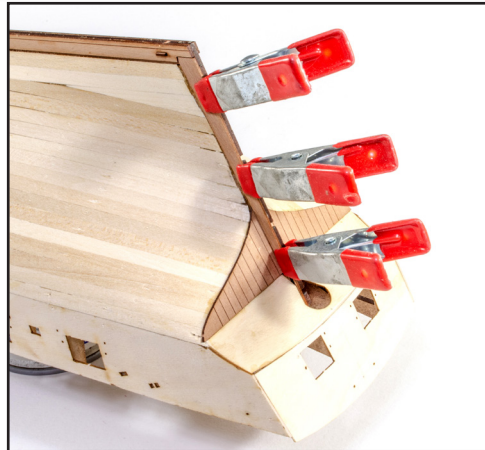

131. Glue in place as shown. NOTE: On your kit, we have moved the peg alignment slot into a better position, so please use this to help with alignment.

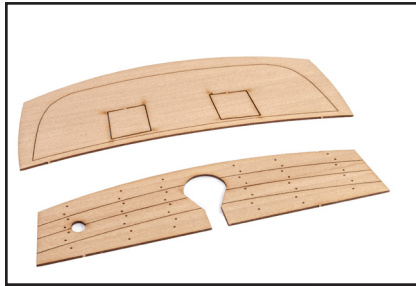

132. From the 0.8mm wood sheet, remove parts 110 and 113. For the moment, we'll only use part 110.

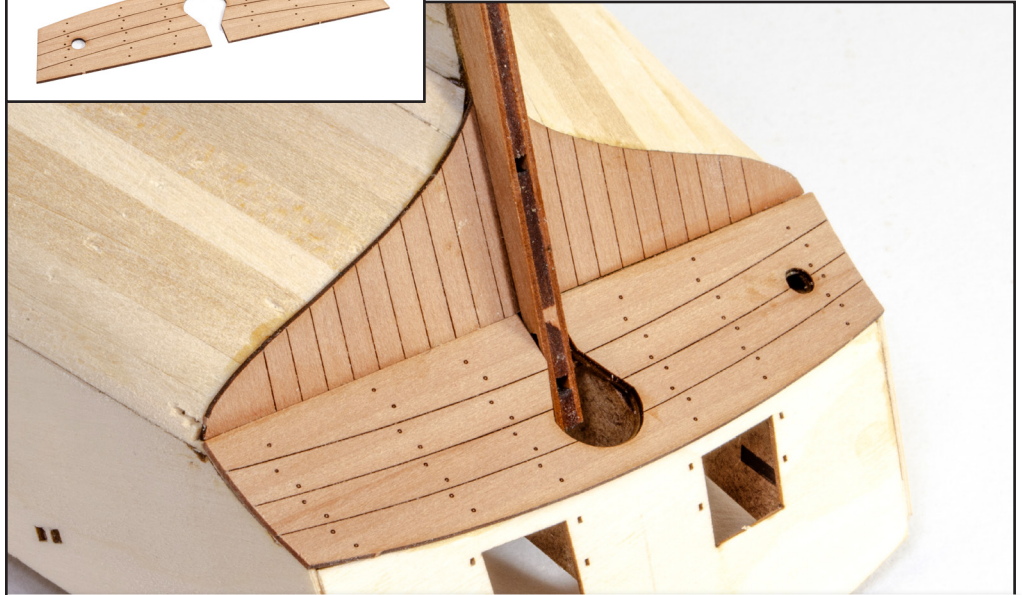

133. Glue part 110 into place as shown. This should naturally sit centrally due to the rudder post parts you just fitted, and the water closet hole on the left should align with the one in the ply level below. There isn't too much of a curve here, so you can just glue and hold this until it dries so you won't need to make pin marks in it. Sand the overhang of this part flush on both sides of the hull.



134. From the 3mm MDF sheet, remove both sets parts 2R to 10R, and both sets 2L to 10L. One of these will sit on top of the other in each set, and will be pegged together with parts GPJ3. Assemble the parts so you can see the part number for easy reference. These assemblies fit through the gun ports and will help you align the outer (and inner) bulwarks.

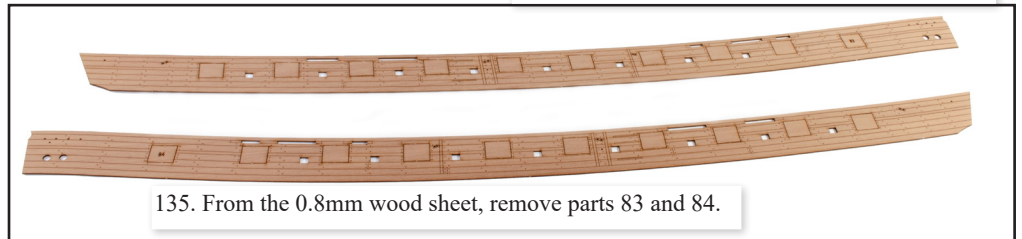

135. From the 0.8mm wood sheet, remove parts 83 and 84.



136. If you wish, you can soak the forward portion of each of these parts and leave them on the hull to dry so that retain a curve at the bow. If you do soak these, remember that you **MUST** leave the parts around 24hrs to thoroughly dry out as pear expands quite a lot when wet.



138. Wish both bulwarks fitted, Harpy will look like this.



137. Now glue each bulwark onto the hull, pinning if necessary, and also clamping. Use those gunport jigs to ensure correct port alignment, but make sure you don't accidentally glue them in situ! Don't worry about any overhang at the rear. That will shortly be fixed. Leave these parts to thoroughly dry.



139. In the same manner as with the first layer of planks, use the pearwood planks to create a second layer. We suggest that you **DON'T** use pins for this layer as it will be seen when finished. For our prototypes, we use Gorilla Glue CA gel for controllability and predictability when applying. We use small dots about 2mm diameter and 2 or 3mm apart down each strip and slowly apply each one, making sure the wood is bonding as you progress.



140. Once planked, mask off the areas with engravings, including the lowest engraved line on each bulwark. You will need those lines when it comes to fitting the wales. Now sand the hull smooth and evenly all over so no plank edges can be seen, or felt with fingers.

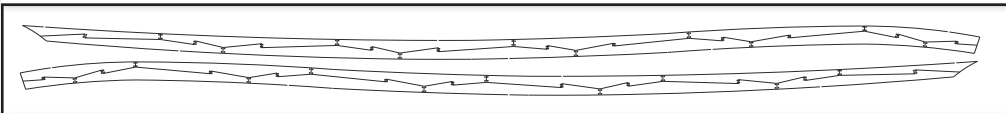

141. From the 0.8mm wood sheet, remove parts 85 and 86, starboard and port respectively.



142. Soak the forward edges of each part and then pin them into place on the hull until dry. Use the lowest engraved bulwark line as the position for the top of each wale. To sit the wales snug against the prow, you will need to gently bevel the inside forward edge. NOTE: Each set of engraved nails on the wales have one cut all the way through. Use these holes for your pins so you don't make these parts.



143. When removed from the hull, the wales will now have a good curve to them, which will make fitting them much easier.



144. You can now glue the wales to the hull, in exactly the same position as before, pinning as you go along.

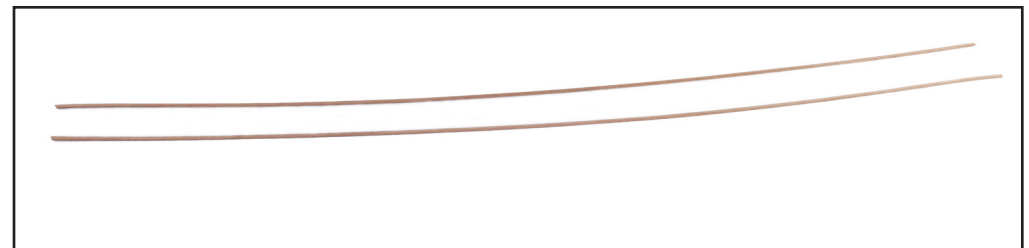

145. From the 0.8mm wood sheet, remove both parts 87. The straight, angled end will be the rear of the part, and the scalloped end is the front.



146. Glue these in place along the top side of each bulwark, along the top of the first engraved line down each part.



148. Using pliers or a suitable tool, twist off the MDF bulkhead ears above deck height. Also remove the two parts against the inner stern counter.



147. Use a piece of sandpaper to sand flush the bulwarks, wales and strips to the stern and stern counter areas.



149. Use both a knife and sandpaper to remove any remnants down to deck height.



150. Harpy is now starting to look very different.



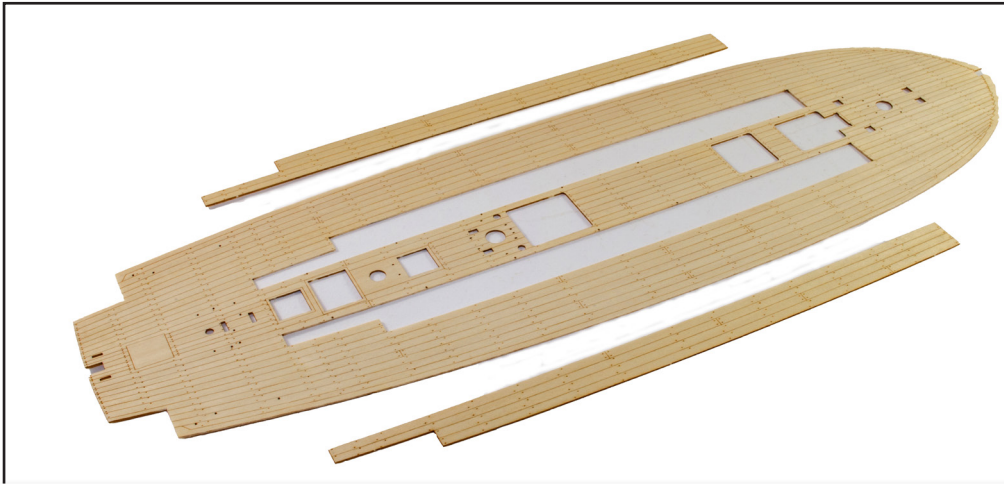

151. You will now need the engraved deck. Remove all the parts which are shown in grey. You can retain the two long portions if you wish to leave the deck complete, or simply not remove them at all.

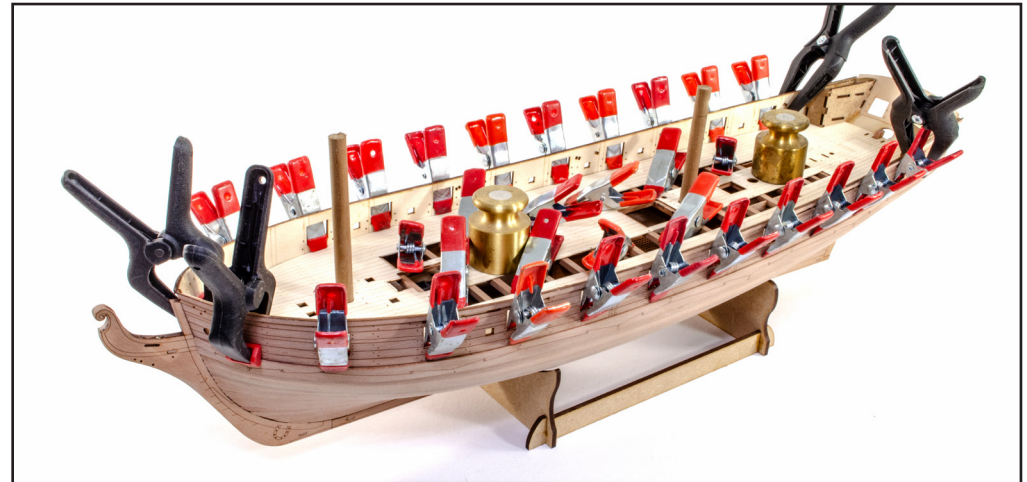

153. Now carefully glue the deck into place, clamping as you go. We highly recommend the 2-inch clamps seen in the gunports. These hold the deck down nicely at the edges.



152. Trial fit the deck into the hull but carefully flexing it. If any material needs removing from the deck, do this carefully until the deck sits flat down onto the ply sub deck. When in place (no glue), use a pencil to draw around the open areas of the deck. These lines will be used as a guide NOT to add glue into those areas!



154. Here's an 'achievement' photo for you, so you can step back and admire the wonderful work you've done so far.

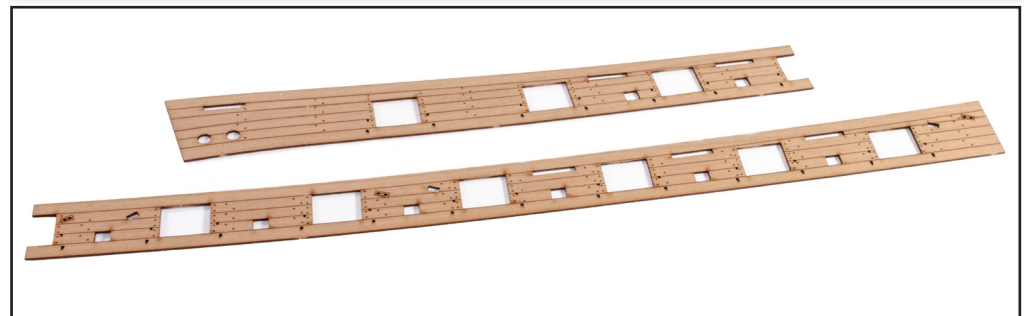

155. From the 0.8mm wood sheet, remove parts 98 and 98R. Mark these numbers on the reverse, as they are a pair.

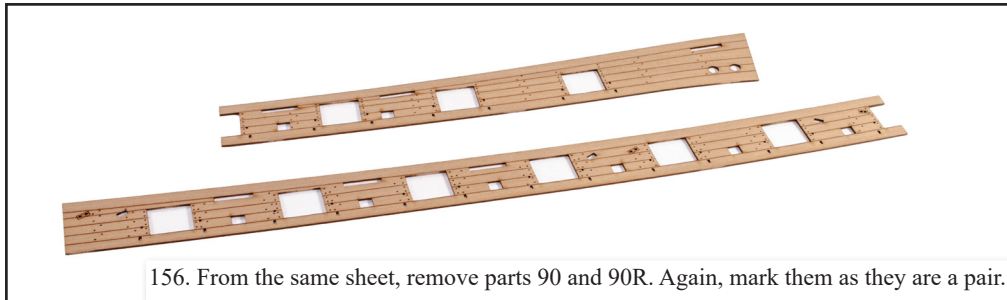

156. From the same sheet, remove parts 90 and 90R. Again, mark them as they are a pair.



157. There is no need to soak the shorter forward bulwark parts here, but it is a good idea to push them into position and clamp them for 24hrs so the fibres relax, and it will make it easier to fit when gluing the parts.



158. So as not to get red paint anywhere near the model, we suggest you mask the upper and lower sections of these parts, and then paint them red before gluing in place. We've also used scrap wood to protect the painted surface from the clamps. Here you see part 90 being clamped into place after glue. Leave to thoroughly set. NOTE: You will need to bevel the inside front end of this part so that it pushes fully into the inner prow. Make sure those gunports are fully aligned. Use the gunport jigs if you feel this will help you.

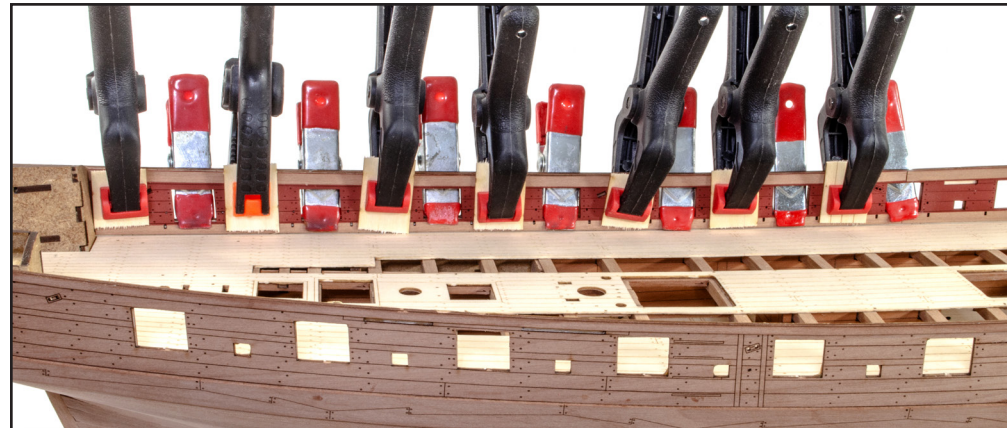

159. Now do the same for part 90R, seen here after gluing and clamping. You may need to trim this slightly at the rear so that it fits flat along the whole length.

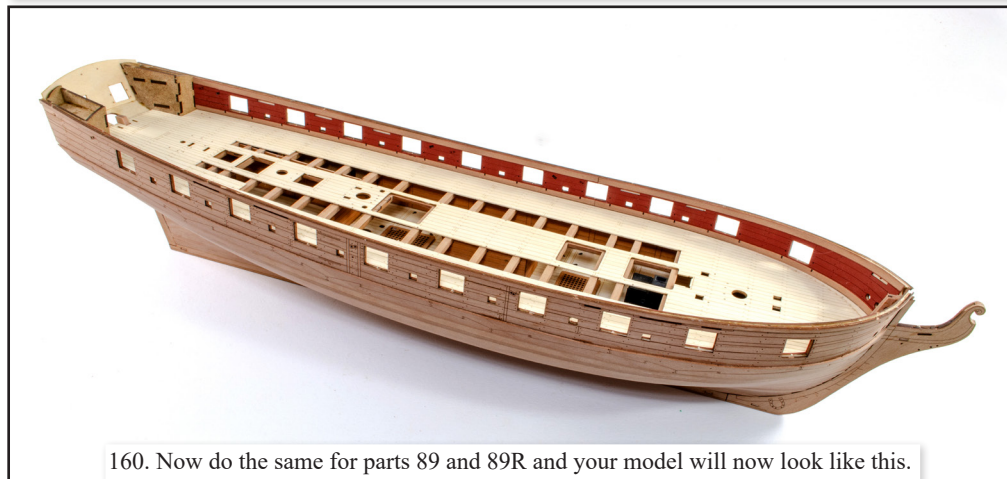

160. Now do the same for parts 89 and 89R and your model will now look like this.

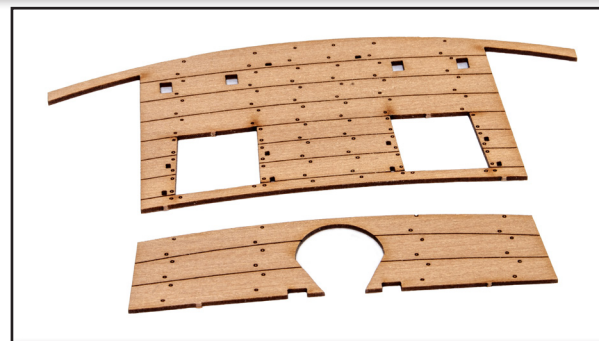

161. From the 0.8mm wood sheet, remove parts 108 and 109.

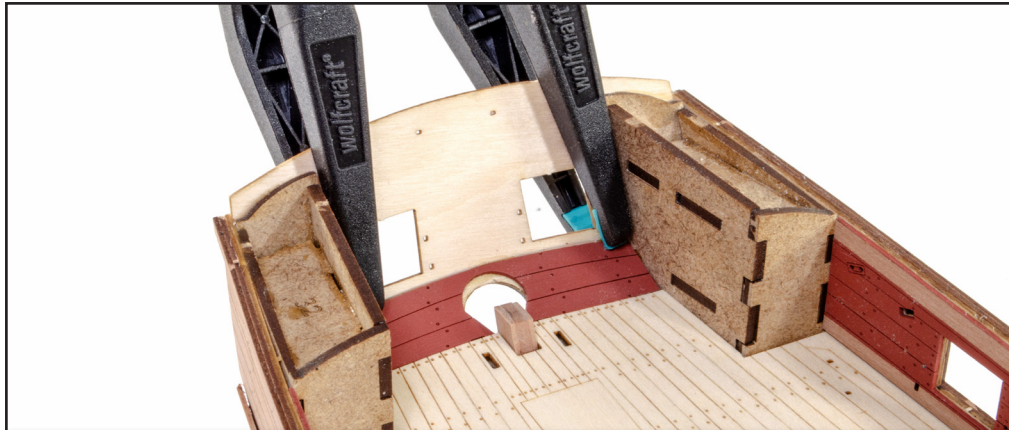

162. Paint these parts in red and first install part 108 as seen. The lower edge tucks down behind the back of the deck. Use clamps to help maintain the curve while the glue sets.

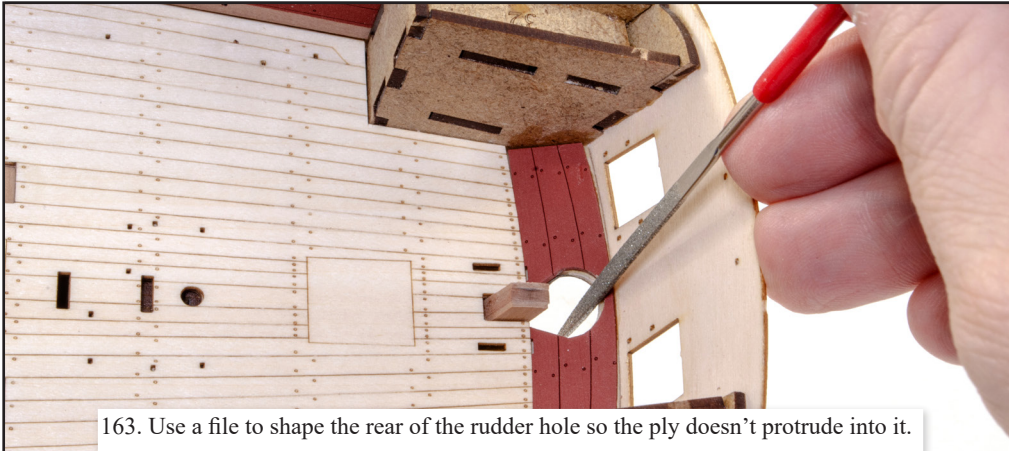

163. Use a file to shape the rear of the rudder hole so the ply doesn't protrude into it.



164. Now glue and clamp part 109 in place.

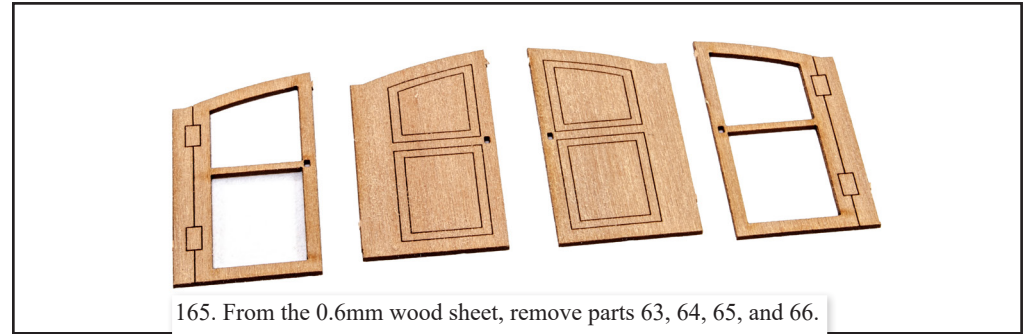

165. From the 0.6mm wood sheet, remove parts 63, 64, 65, and 66.



166. Assemble the parts as shown.



167. Glue the door assemblies in place as seen here.

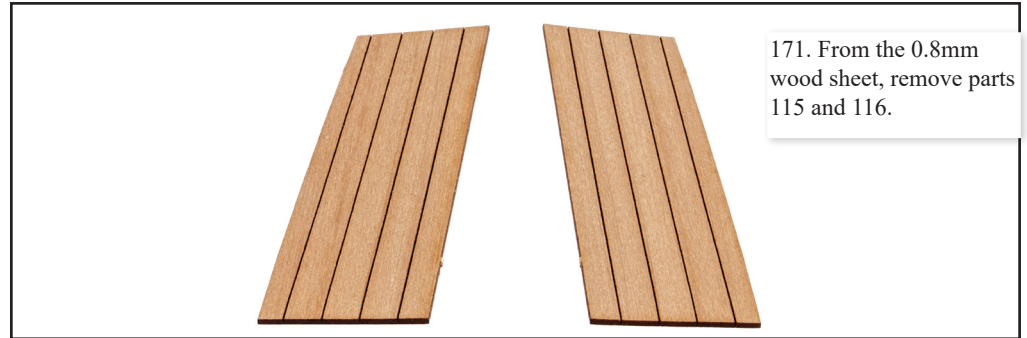
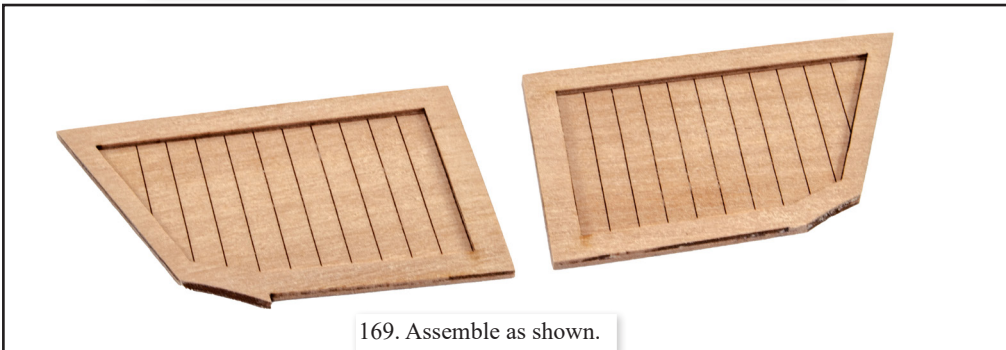
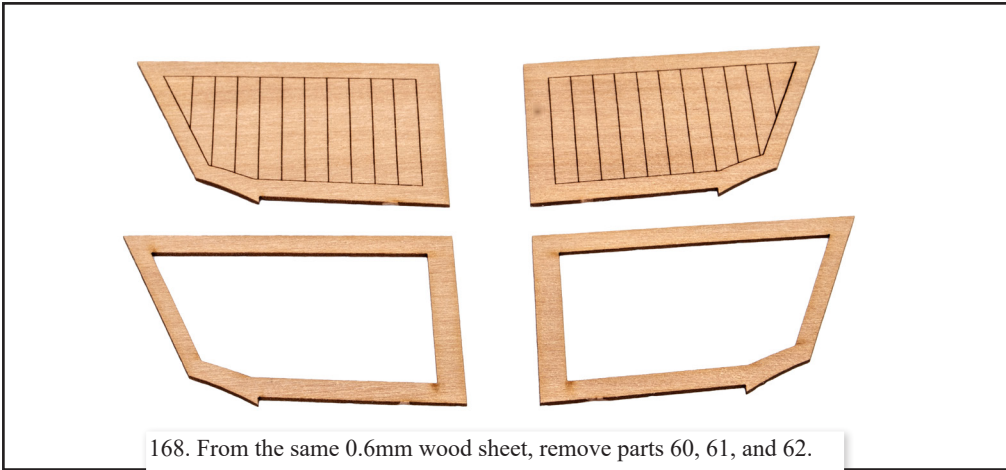

172. Glue into place as shown. You may need to do some final trimming work on the cabins before you fit the roof parts.



173. Use a rigid sanding tool or flat needle file and clean up the gun ports so they are even through the layers. You can use a small file for the Sweep holes.



174. From the 0.8mm sheet, remove parts 92 and 92a. You can number these on the reverse as they are a pair.



175. Paint both of these parts in red, and glue part 92 as shown here. Clamp until thoroughly set.

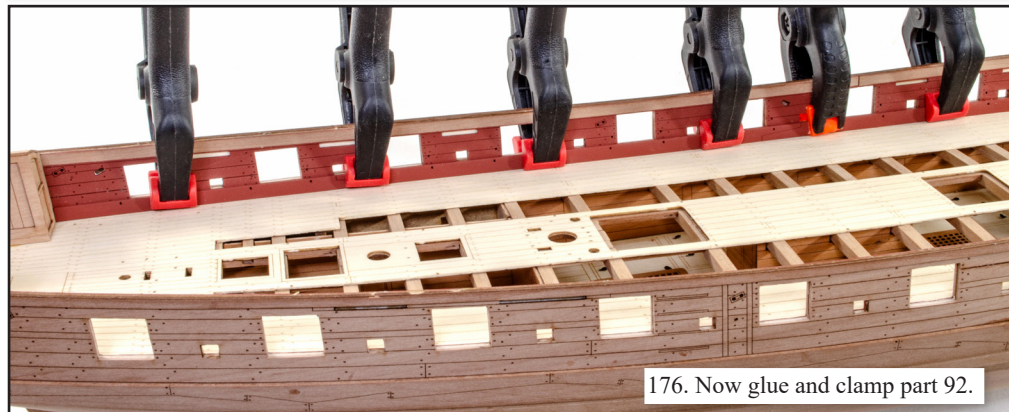

176. Now glue and clamp part 92.

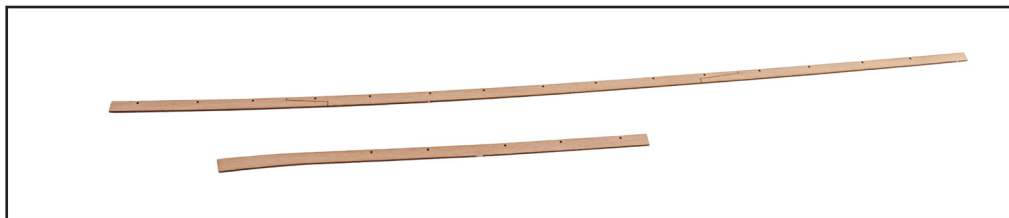

177. Remove parts 91 and 91a. Paint and glue these into place in the opposite side of the hull as you did with the previous parts.



178. From the 0.8mm wood sheet, remove both parts 88.



179. Paint these red and glue into place as shown here. NOTE: The scalloped end of these parts is the bow end. You may need to trim the parts slightly at one end, so they fit exactly.



180. Harpy will now look like this.



181. Take a 12-inch steel rule, or similar, and wrap it in sandpaper. Now even draw this across the tops of the bulwarks, equally levelling them.



184. The wales and upper strip now need to be painted black. To do this, we masked the rest of the hull and used an aerosol for the black paint.

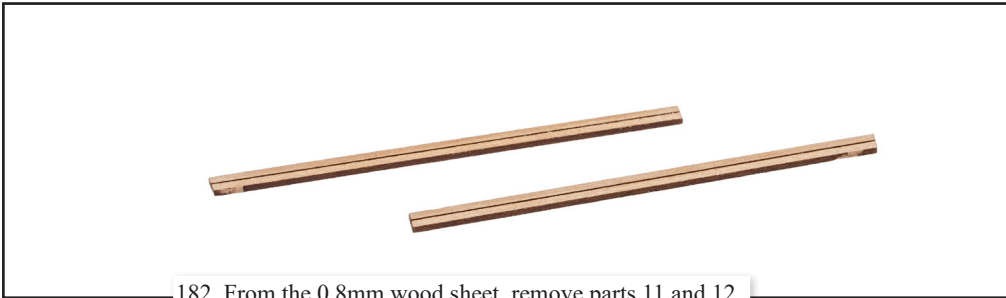

182. From the 0.8mm wood sheet, remove parts 11 and 12.



185. When painted, the hull should look like this.

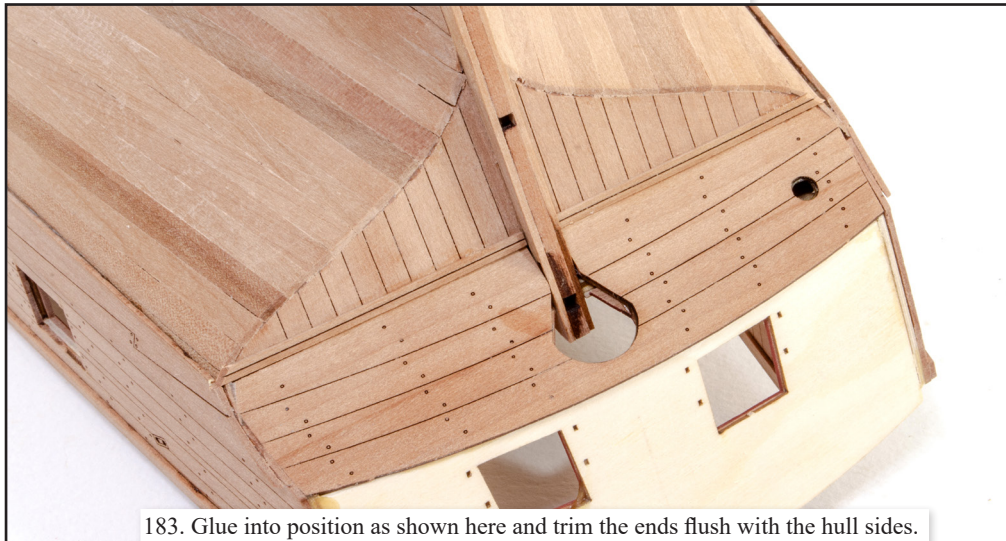

183. Glue into position as shown here and trim the ends flush with the hull sides.



186. We need to now prepare the hull under the waterline before we can copper it. To do this, add a waterline to the hull, and make it a few millimetres below the actual waterline shown on plan. The reason for this is that we don't want any filler appearing above the actual waterline, later in the build.



187. Now mask off the rest of the hull and fill/sand the hull until you have a good surface onto which you can add copper.



188. Take your copper tape and cut it into lengths that are 18mm long. You can leave a few meters of copper uncut on the roll.

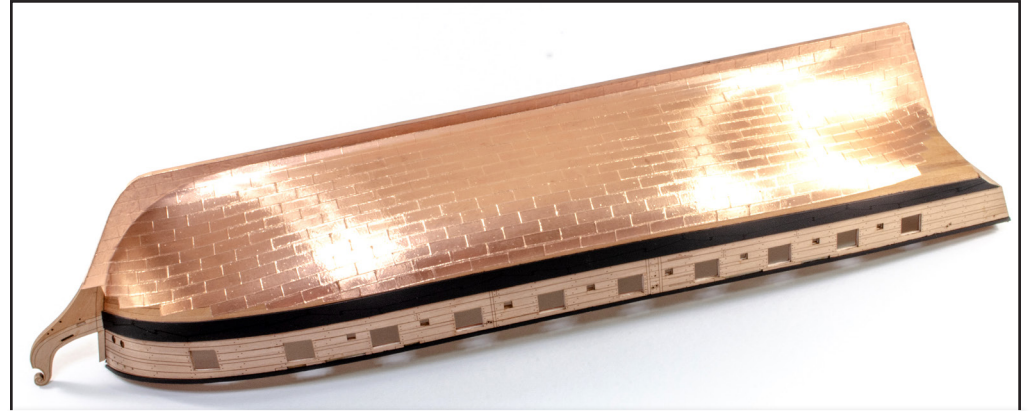

189. Start coppering at the lowest edge on the keel. On our prototype, we managed to add three whole lengths of copper tape, one after the other, before switching to the plates. **IMPORTANT:** When removing the backing from the copper, keep the copper as rigid as you can and peel the backing away from it, instead of peeling the tape from the backing. Doing it the right way will ensure you get minimal/zero wrinkles on the copper. You'll notice here that I have coppered well above where the waterline will be.

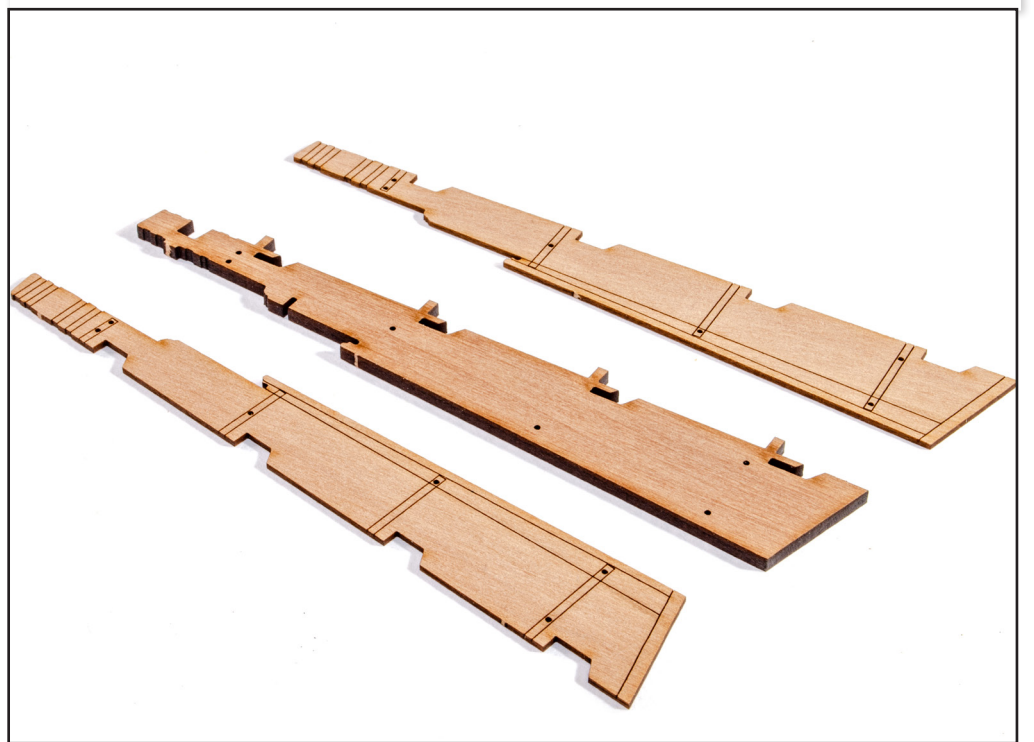

190. From the 1mm wood sheet, remove parts 141 and 142. These are the engraved outer rudder parts. From the 2mm wood sheet, remove part 239. That's the rudder core.



191. Glue the outer engraved parts to the inner core, clamping as you go to prevent any curling.



192. Now copper the rudder as you did with the hull. It's always better adding too much as it can be removed later.

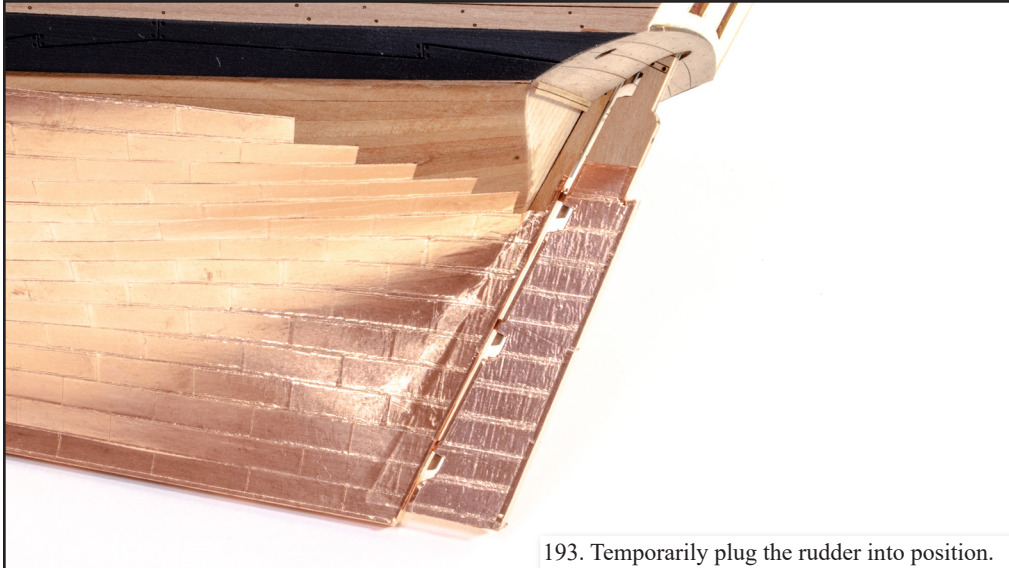

193. Temporarily plug the rudder into position.

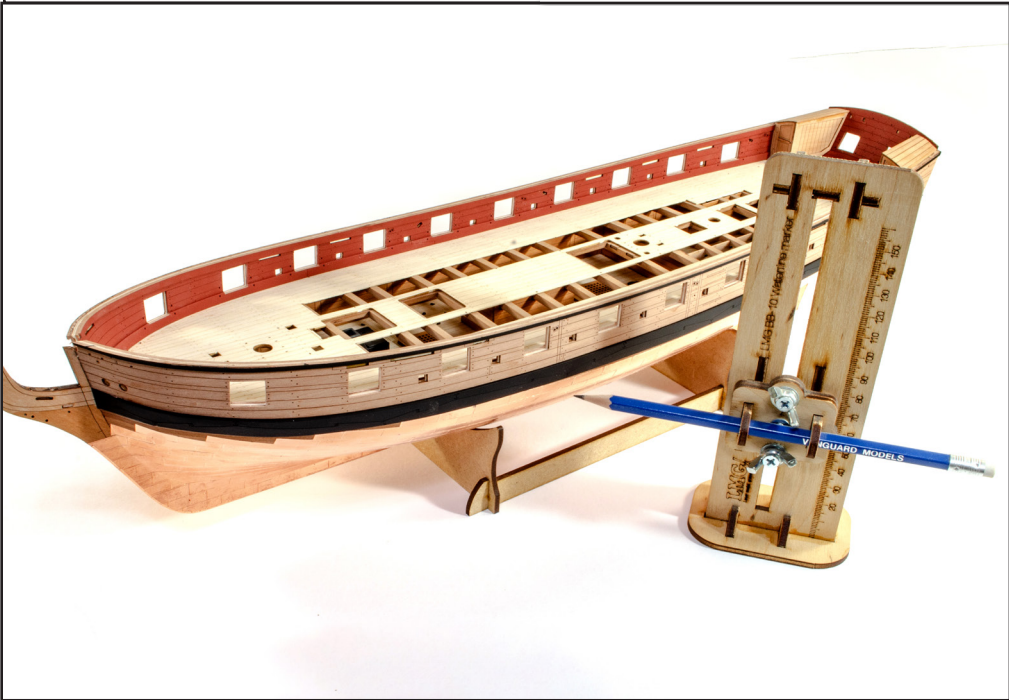

194. Sit the hull in the cradle, making sure the pin in the rear former sits into the hole in the underside of the keel. This makes sure your model is at the right attitude for a waterline to be marked. Use a waterline tool and lightly mark the waterline with the pencil. Check the position of this from the plan and ensure that the tool is at the correct height at bow and stern before you mark.



195. Use a sharp knife and gently cut along the waterline, enough to cut through the tape only. Remove all the copper from above the waterline. It's up to you at this stage if you wish to polish, degrease and seal the copper. Personally, we do this just before fitting out the hull and adding the stern. I'll explain my process in the place where I do this.



196. From the 4mm wood sheet, remove part 272. From the 2mm wood sheet, remove part 245.



197. Glue these together as shown. You can now paint this in the same colour as the inner bulwarks, or later, with the other deck fittings.



198. TEMPORARILY plug the assembly into the deck as shown and remove just enough material from the entry point at the bow, where the 6mm bowsprit will sit. Use your dowel to check that it will sit on the prow, and comfortably into the hole in the deck assembly. Once complete, remove both the dowel and the assembly from the deck.

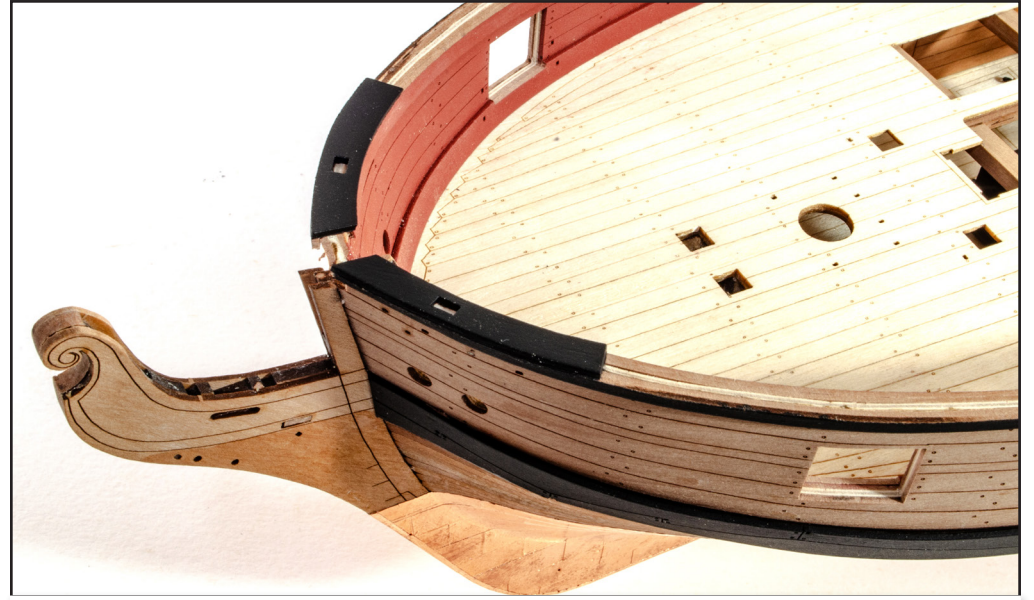

200. Paint all parts black. Now take parts 94 and glue into place at the bow, as shown, leaving space for that 6mm dowel to still be inserted.

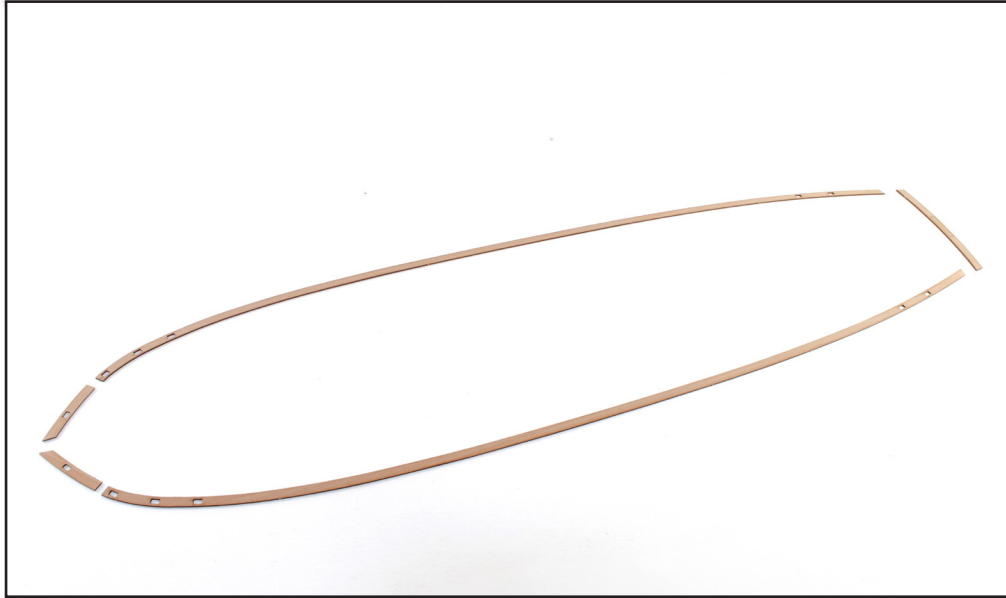

199. From the 0.8mm wood sheet, remove both parts 93, both parts 94, and part 95.



201. Before we can add the rest of the gunwale parts, we must build and add the catheads. From the 2mm wood sheet, remove parts 256, 257, 258, and 259. From the 1mm wood sheet, remove all parts 160, and both parts 161.



202. Glue the 2mm parts together to create two catheads. NOTE: These parts are paired. Parts 256 and 257 are a pair, and parts 258 and 259 are another pair.



203. Now glue the other parts into place as shown. Parts 134 are the end caps. Clean up the assemblies and paint them black, but not on the surfaces which will be glued to the hull.



205. Now glue parts 93 to the top edge of the bulwark, so it's flush with the outer black rail.



206. From the 0.8mm wood sheet, remove parts 98 and 99. These are the rails for the port side of the hull.



204. Glue both catheads into position. NOTE: Assembly from parts 256 and 257 is to be glued to the starboard side, and assembly from 258 and 259 is to be glued to the port side.

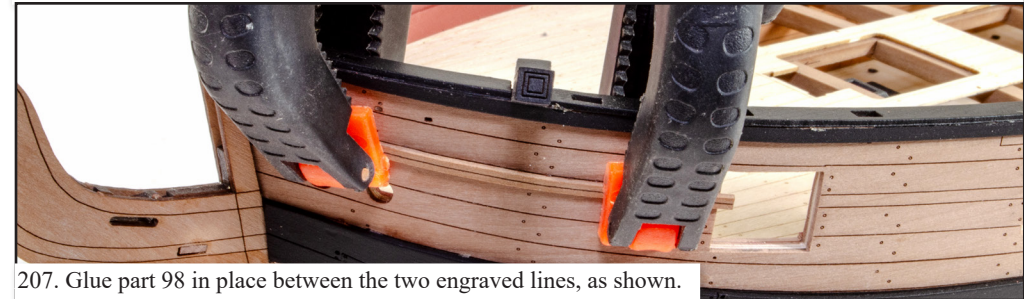

207. Glue part 98 in place between the two engraved lines, as shown.



208. Now glue part 99 into place as shown. The narrow sections are designed to span the gun port openings.

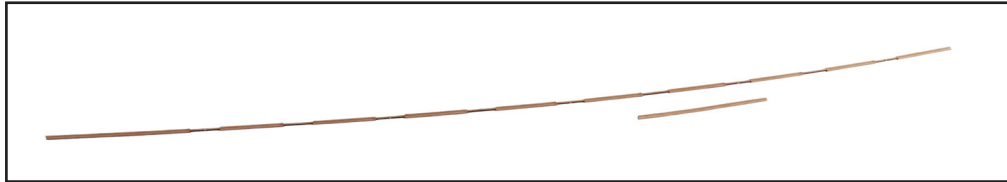

209. Now remove parts 96 and 97 and glue onto the opposite side of the hull, in the same way.



210. Use very sharp cutters or a razor saw and remove the sections that span the open gunports. Sand the edges of the rails flush with the gunport sides.



211. The rails and gunwales now need to be sanded flush with the stern.



212. From the 0.8mm wood sheet, remove parts 113 and 114.

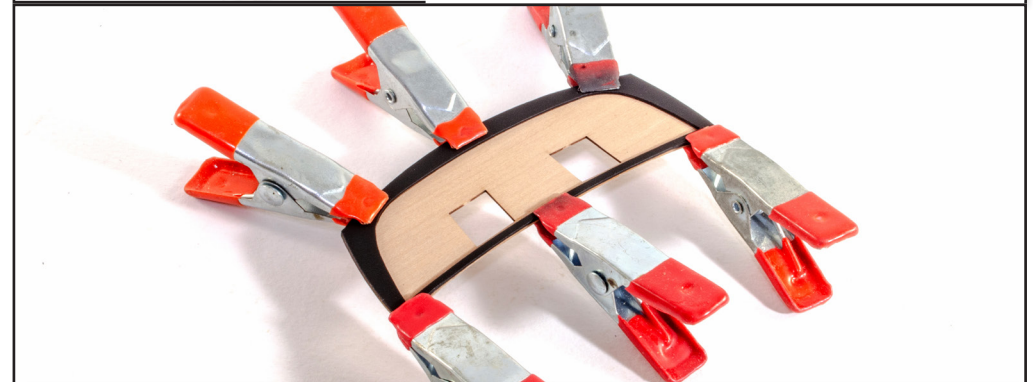

213. Paint part 114 in black and then glue the two parts together, using the engraved lines on 113 as your guide.

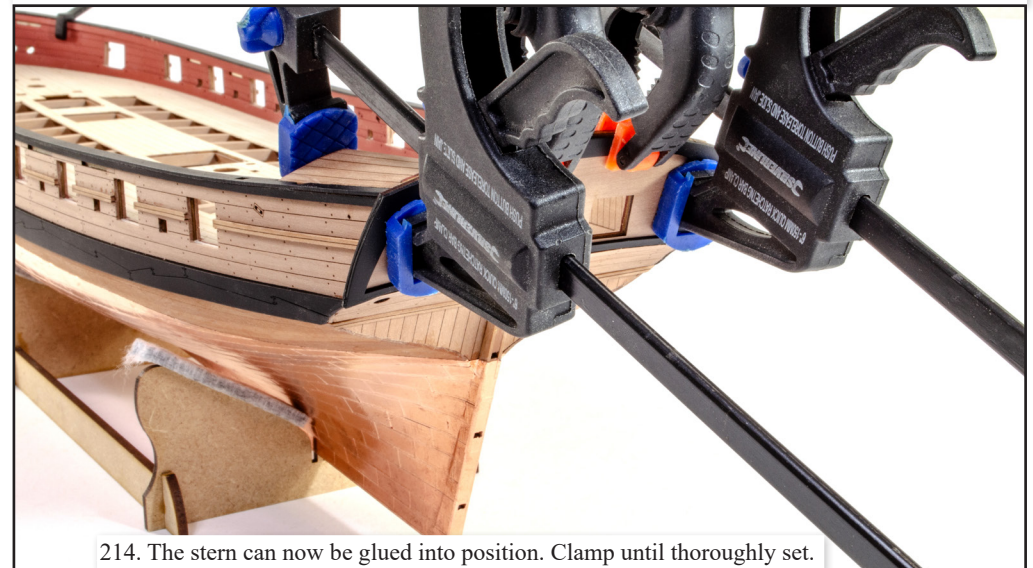

214. The stern can now be glued into position. Clamp until thoroughly set.

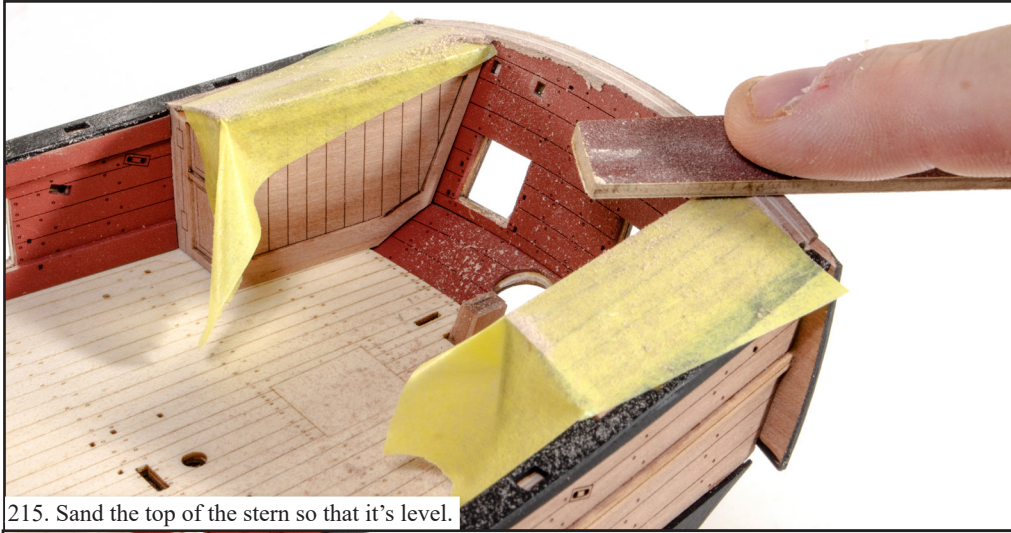

215. Sand the top of the stern so that it's level.



216. Now glue part 95 into place.



217. From the 0.8mm woos sheet, remove both parts 100.



218. Temporarily sit in position on each side of the hull and score the side rails where these parts sit over them.

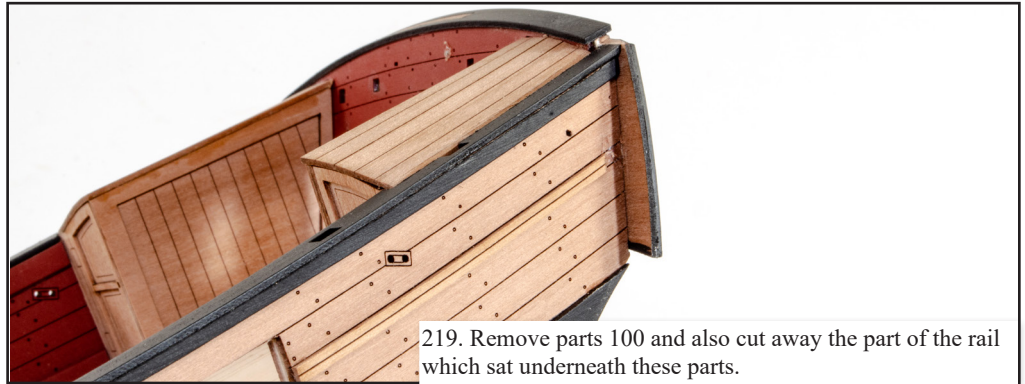

219. Remove parts 100 and also cut away the part of the rail which sat underneath these parts.



220. Parts 100 can now be glued into place, sitting flush with the rail. NOTE: It's a good idea to paint the forward edge of these parts so you don't mark the hull.



221. From the 0.6mm wood sheet, remove both parts 82, paint black and then glue into place as shown here. You should also paint the small visible area of the inside stern in black too. Now is also a good time to paint the gunport linings in the same red as the interior.



222. From the 1.5mm wood sheet, remove all parts 215.



223. Glue these to the side of the hull, in the vertical engraved areas.



224. From the same wood sheet, remove both parts 216. From the 0.6mm wood sheet, remove all parts 216a. Assemble as shown.

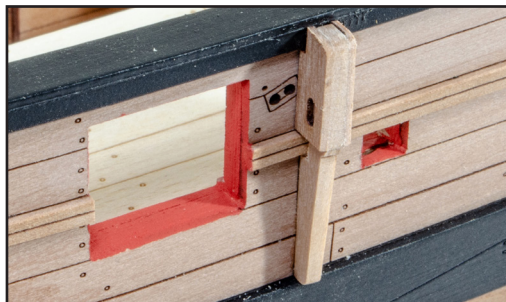

225. Glue into place on the sides of the hull, in the remaining vertical engraved areas.



226. From the 0.6mm wood sheet, remove all parts 56 and 57. Assemble as shown.

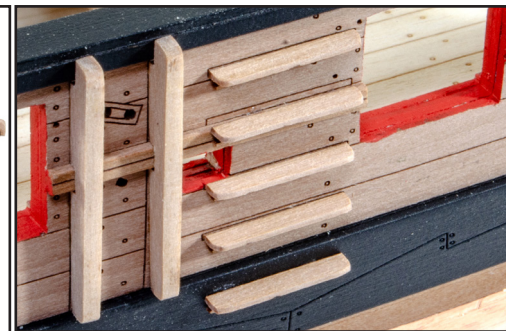

227. Glue the steps into place in the engraved areas as shown. One step will also be fastened to the wale, in the same sequence as the others.



228. From the 0.2mm PE sheet, remove two parts each of PE-1 and PE-2.



229. Cover these in copper tape (or paint copper) and glue into place as shown here. If you wish, you can use short brass pins to simulate rivets.



230. From the laser cut black card, add the straps to the top of the rudder (R9) and also the hinges R5, R6, R7, and R8 to both sides. From the 0.6mm PE sheet, remove part PE-49. Glue that into place as shown on the plan.

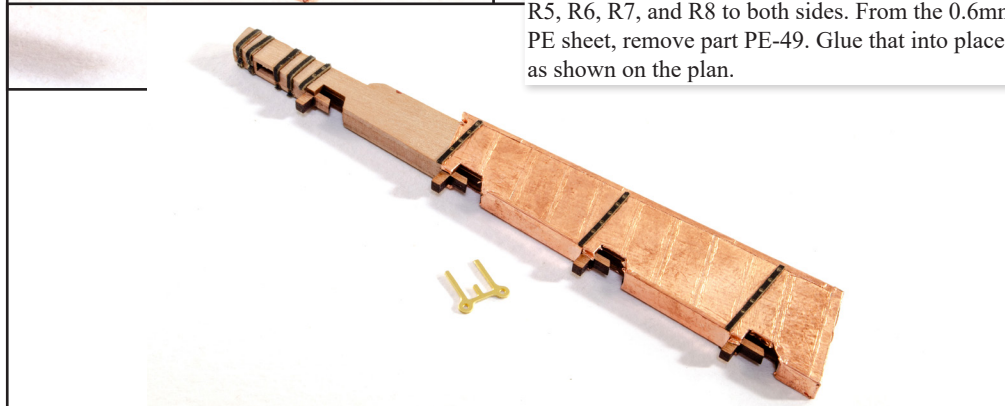



231. The rudder can now be glued onto the hull and the hull-side rudder hinges R1, R2, R3, and R4, now glued. Use copper tape to cover up the hinges below the waterline. At this point, the copper was finished. To do this, we advise you wear powder-free latex or nitrile gloves. This will prevent transference of grease during the next steps. Firstly, wipe the copper with ethanol or isopropyl alcohol to degrease it. Next, use 00000-grade steel wool to gently polish the copper. Lastly, use compressed air to remove any steel lint from the hull before applying another quick wipe with alcohol. At this point I airbrush matt varnish over the whole copper area and allow to cure overnight.

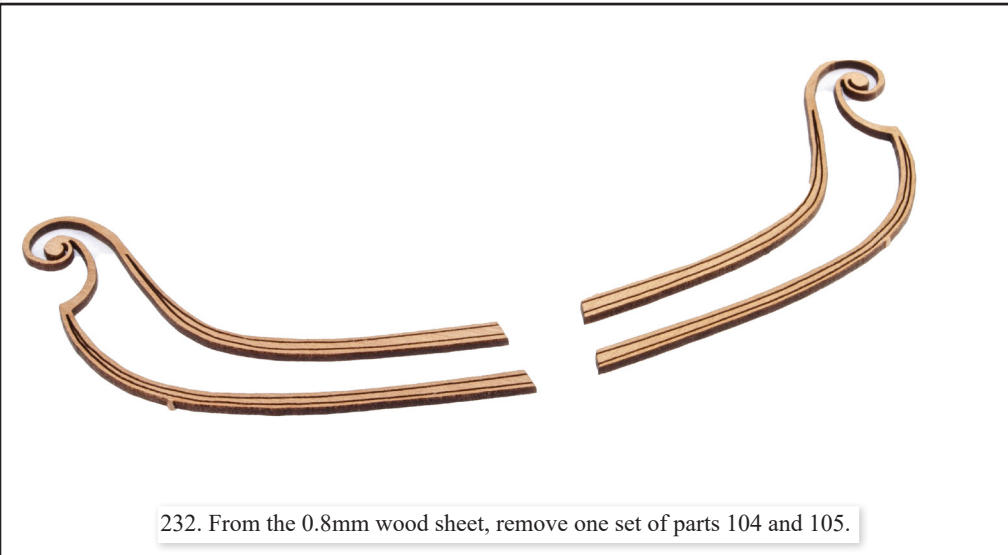

232. From the 0.8mm wood sheet, remove one set of parts 104 and 105.



233. Paint the area between the engraved lines in black and paint parts 104 and 105 in ochre. These parts can now be glued as shown, within the engraved areas. From the 0.2mm PE sheet, remove parts PE-10 and PE-11. Paint these ochre and glue into place as shown.



234. From the 2mm wood sheet, remove all parts 235.



235. Glue into place as shown here and on your plans. You will probably need to refine each part for maximum contact. Note that these sit on top of the tail of the ochre parts, with the upper part sitting on top of the wales.



236. From the 1.5mm wood sheet, remove both parts 209.

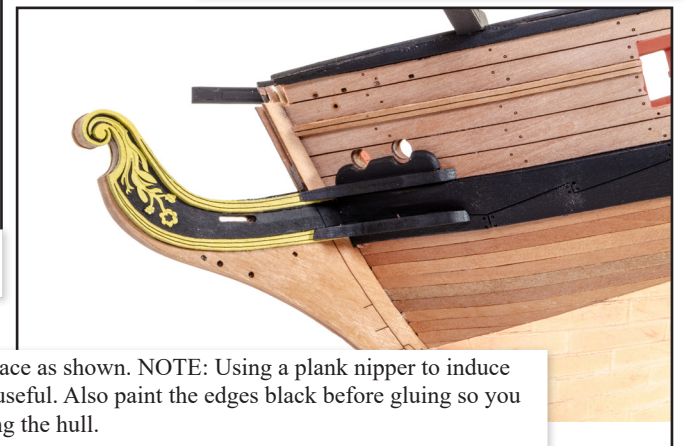

237. Glue into place as shown. NOTE: Using a plank nipper to induce a slight curve is useful. Also paint the edges black before gluing so you don't risk marking the hull.



238. From the 2mm wood sheet, remove part 240. From the 1.5mm wood sheet, remove one each of parts 203 and 204.



239. Glue as seen here and on plan.



243. From the 2mm wood sheet, remove both parts 242.



240. Paint the 'v' parts in black and glue the assembly into place on the prow, as seen here.



244. Paint black and glue into position between the ochre rails and the underside of the catheads. You may need to adjust these parts for maximum contact on both.

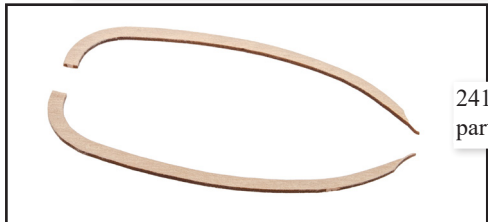

241. From the 1mm wood sheet, remove two parts 147.

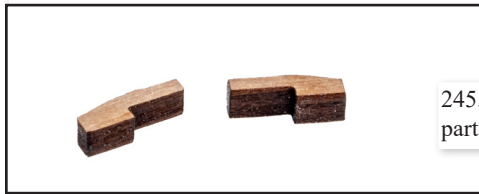

245. From the 2mm wood sheet, remove both parts 260.



242. After sanding the 'v' parts as shown on plan, paint parts 147 in ochre and glue into place as shown here and on plan. These parts should sit flat against the 'v' parts for maximum contact.



246. Glue these into position on the catheads, as shown. Paint black.



247. From the 0.2mm PE sheet, remove two sets of depth markings, paint black, and apply to the hull as shown. Marks are on the prow to assist with positioning.



248. From the 4mm wood sheet, remove both parts 234. From the 1mm wood sheet, remove all parts 133 and both parts 134.



249. Assemble as shown.



250. Paint the davits black and glue into position as shown.

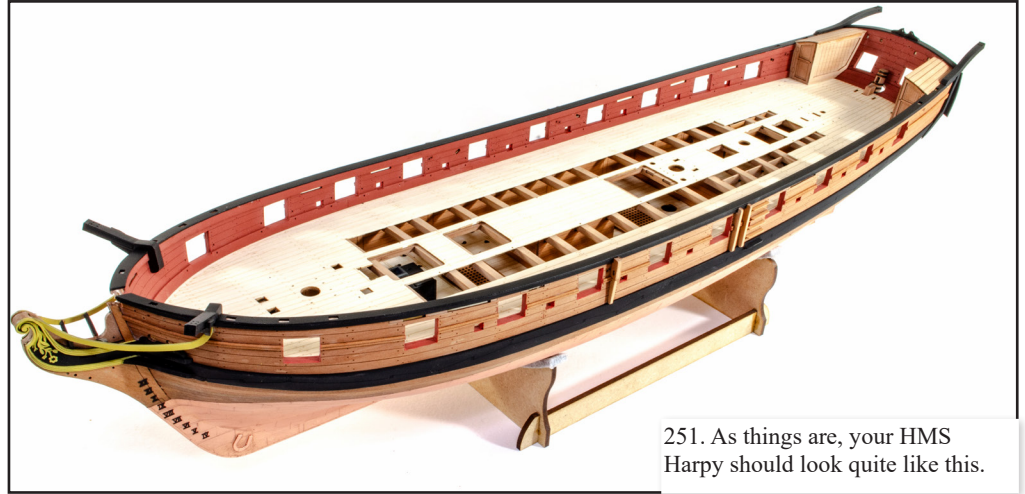

251. As things are, your HMS Harpy should look quite like this.



252. Following your plan sheet, you now need to install eyelets PE-14 from the 0.4mm PE sheet. There are four per gun port, including the inner stern ports, and also eyelets to add to the deck. Again, check your plans.

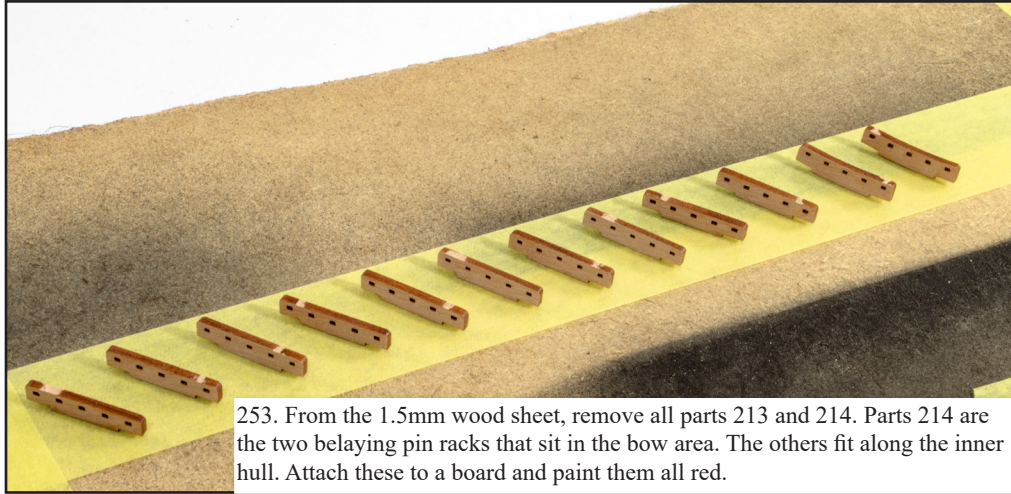

253. From the 1.5mm wood sheet, remove all parts 213 and 214. Parts 214 are the two belaying pin racks that sit in the bow area. The others fit along the inner hull. Attach these to a board and paint them all red.



254. Now fit them along the inner bulwark as per plans. From the same 1.5mm wood sheet, remove all parts 218 and 219. These are the inner bulwark cleats. Paint them red and attach as per plan.



255. From the 1mm wood sheet, remove parts 144, 145, and 146.

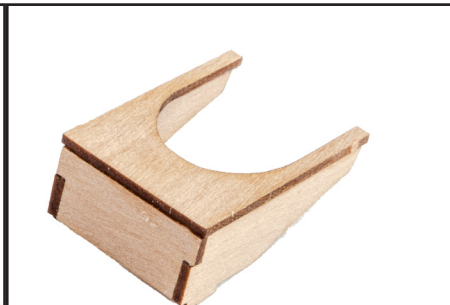

256. Assemble as shown.



257. From the 1.5mm wood sheet, remove part 200. From the 0.4mm PE sheet, add two eyelets for handles. From the 0.2mm PE sheet, add some hinges PE-8.



258. Fit the two previous assemblies into place. Also add the same hinges and eyelets to the cabin doors. From the 0.4mm PE sheet, remove part PE-39 and glue this into the remaining two holes in the inner stern.

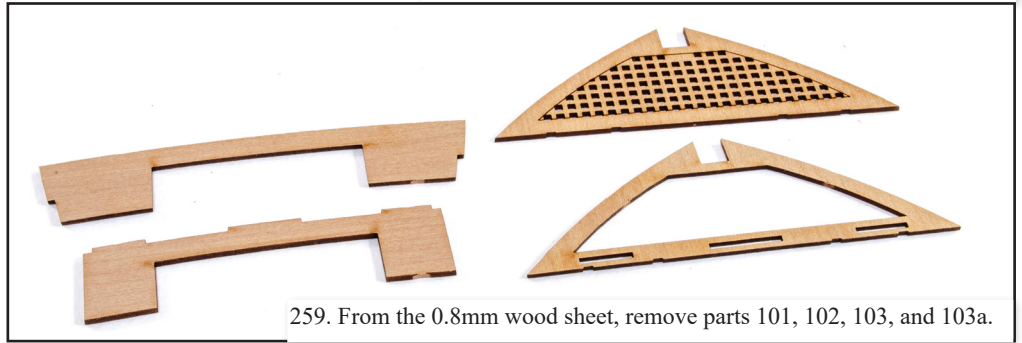

259. From the 0.8mm wood sheet, remove parts 101, 102, 103, and 103a.

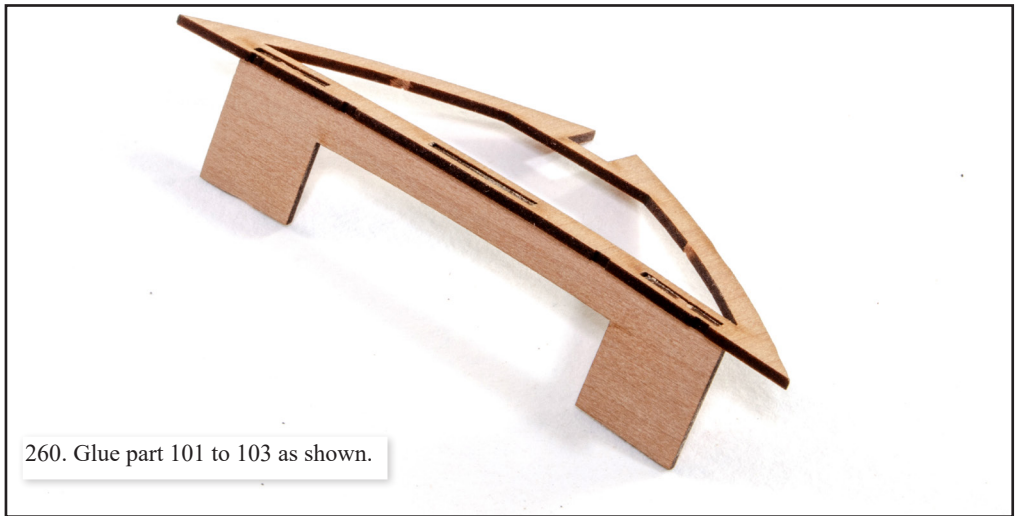

260. Glue part 101 to 103 as shown.



261. Make sure the upper part conforms to the curve on 101.



262. Now glue part 102 in front of 101 and then glue part 103a and top of 103.



266. Now add the remaining steps and add the engraved outer edges.



267. Your ladder will now look like this.



263. This assembly can now be painted and fitted into the bow of Harpy. Some adjustments may need to be made for your particular build. Test fit first.

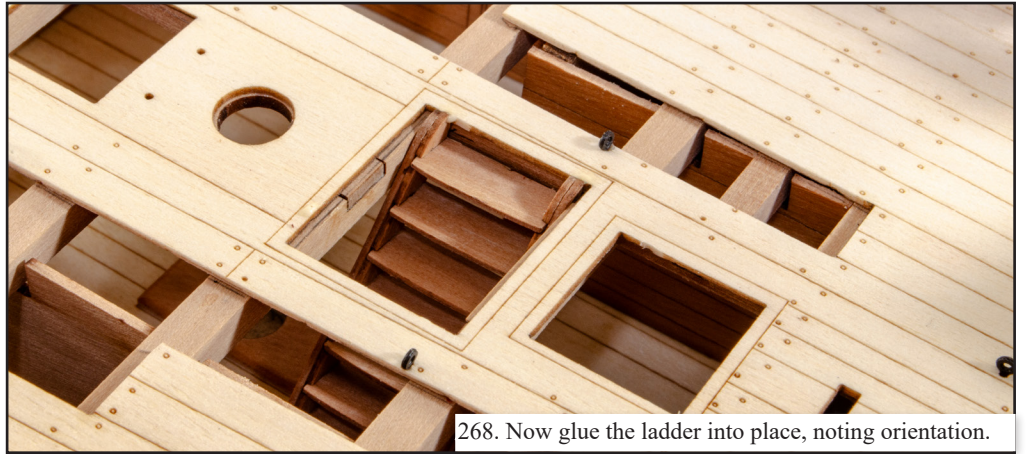

268. Now glue the ladder into place, noting orientation.



264. We now need to make our first ladderway, for the aft hatch. From the 0.6mm wood sheet, remove parts 67, 68, and 69.

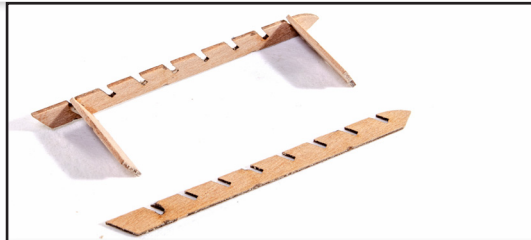

265. Glue two steps into the frames; one at the top and bottom and leave to set. When set, add the opposite frame.



269. From the 1mm wood sheet, remove parts 121, 122, and 123.

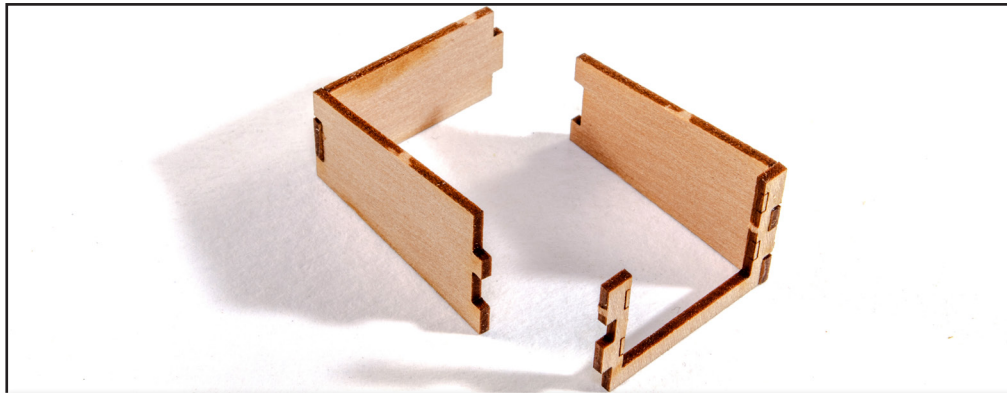

270. Assemble in halves so you can concentrate on making sure each set has a proper 90-degree angle between them.

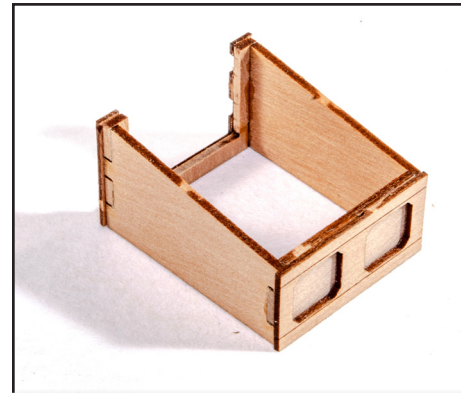

273. Here you can see the rear part attached.

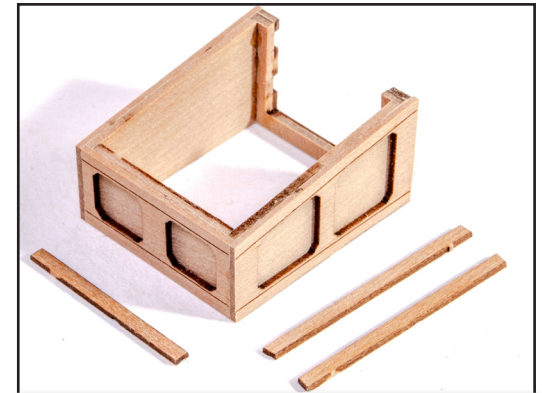

274. Now glue on the side panels and leave to dry before removing any overhang. From the 0.6mm wood sheet, remove parts 54 and 55.

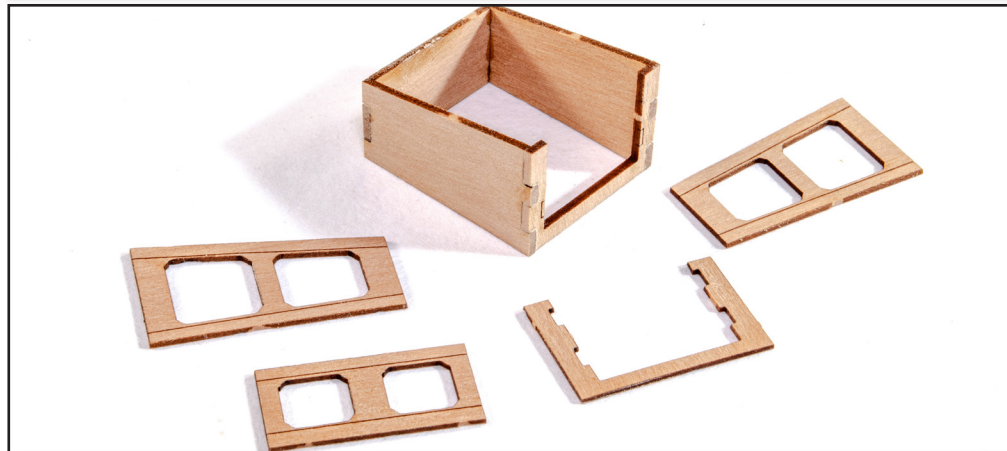

271. Now glue those halves together after they have dried. From the 0.6mm wood sheet, remove parts 44, 45, 46, and 47.

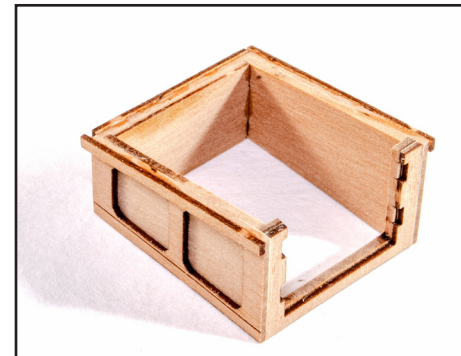

275. Glue part 55 to the top rear of the companionway and when dry, sand the ends flush. Now add parts 54 to the upper sides.

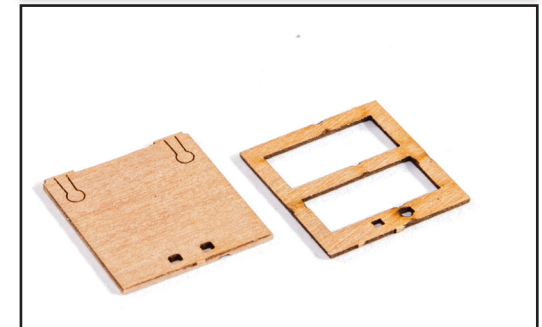

276. From the 0.6mm wood sheet, remove parts 51 and 52.

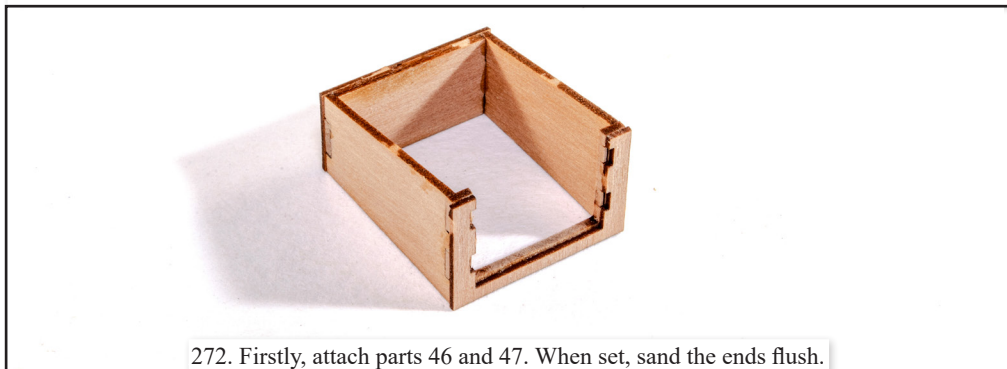

272. Firstly, attach parts 46 and 47. When set, sand the ends flush.



277. Glue together as shown.



278. From the 0.6mm wood sheet, remove parts 48, 49, and 50.



279. Glue those parts together as shown. From the 1mm wood sheet, remove part 124. Level the top of the companionway and then glue 124 onto the top of it.



280. Add two PE-14 eyelets to the doors to create handles. From the 0.2mm PE sheet remove four hinges PE-6 and add to doors. Fit the doors to the companionway.



281. Add two more PE-6 to the upper lid, and also the handle part 53 from the 0.6mm wood sheet. Glue the hatch as shown, or along with the doors, you may choose to pose them in a closed position.



282. From the 4mm wood sheet, remove part 278. From the 1.5mm wood sheet, remove parts 220 and 221. From the 3mm wood sheet, remove parts 271.



283. Refer to your plan and assemble the parts like this.



284. From the 1mm wood sheet, remove part 153, but don't fit quite yet. Also leave the centre infill in place for the moment.



285. From the 4mm wood sheet, remove part 276. From the 3mm sheet, remove part 270. From the 1.5mm wood sheet, remove parts 205 and 206.



286. Refer to your plan and assemble the parts like this.



287. From the 1mm wood sheet, remove part 150, but don't fit quite yet. Also leave the infill in place for the moment.



288. From the 4mm wood sheet, remove part 266. From the 3mm wood sheet, remove part 269. From the 2mm wood sheet, remove parts 243.

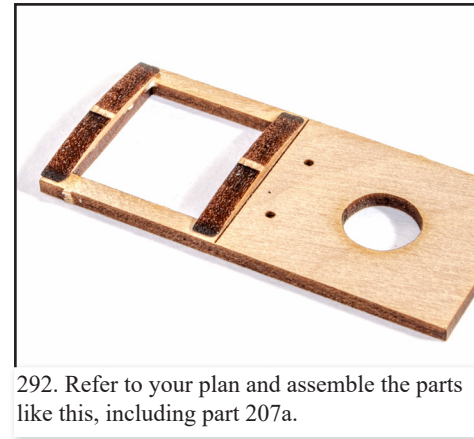

292. Refer to your plan and assemble the parts like this, including part 207a.

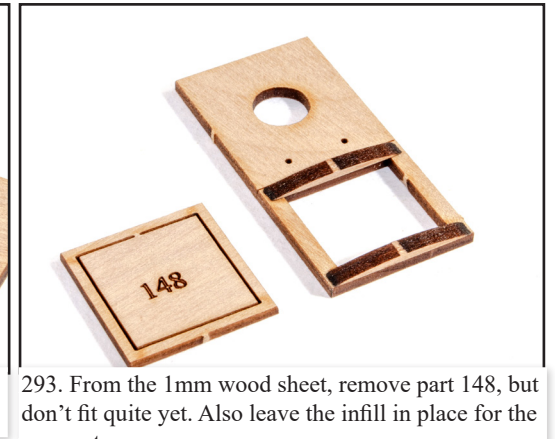

293. From the 1mm wood sheet, remove part 148, but don't fit quite yet. Also leave the infill in place for the moment.



289. Refer to your plan and assemble the parts like this.

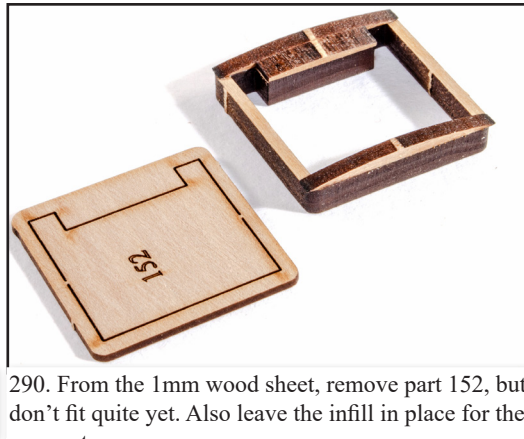

290. From the 1mm wood sheet, remove part 152, but don't fit quite yet. Also leave the infill in place for the moment.



294. The 1mm parts which we've so far left off the assemblies, now need to be curved slightly so they can be easily glued to the assemblies without cracking. To do this, the parts were soaked in water for about 15 minutes and then wrapped and taped around a 250ml paint tin. These were then left to dry for 12hrs to allow them to shrink back to more or less the correct size. Once removed from the tin, they were left a further 12hrs to fully shrink to the original size.



291. From the 1.5mm wood sheet, remove part 207. From the 2mm wood sheet, remove two parts 244. NOTE: Since design, part 207a has also been included, so you can also remove this from the 2mm wood sheet.

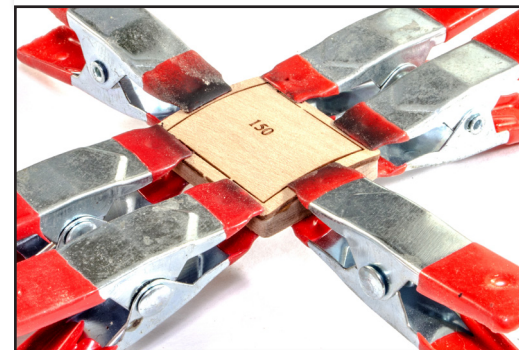

295. The curved parts can now be glued to their respective assembly.

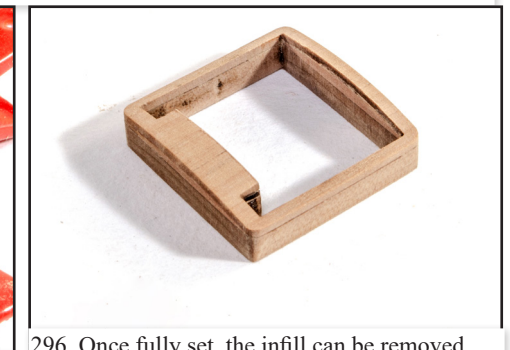

296. Once fully set, the infill can be removed. Now carefully sand and finish the assemblies to they can be painted.

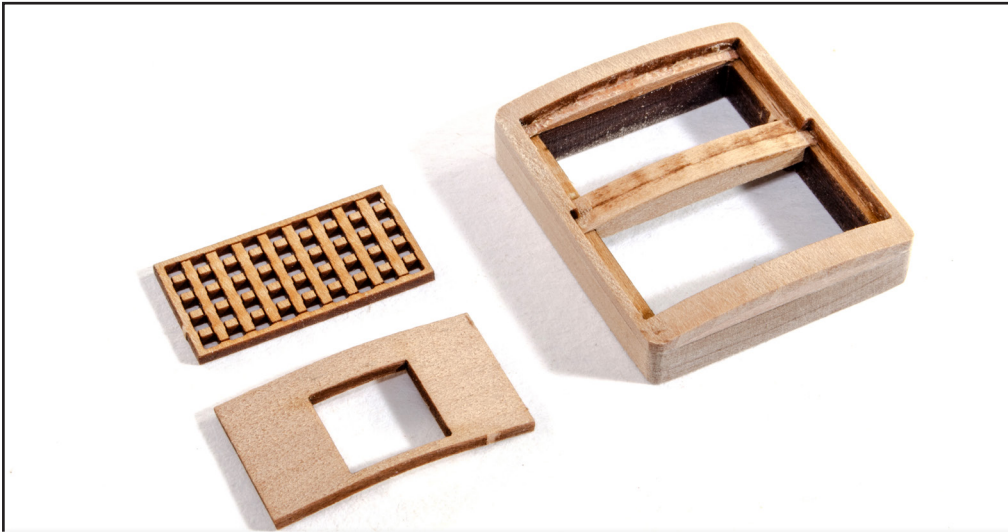

297. The forward hatch assembly also has another curved that needs to be curved and then glued into place, following the same procedure as before. For the forward hatch, this part can be found on the 1mm wood sheet and is part 155. The grates for the assemblies shouldn't need to be soaked to fit easily. For this forward assembly, you will need part 154 on the 1mm wood sheet.

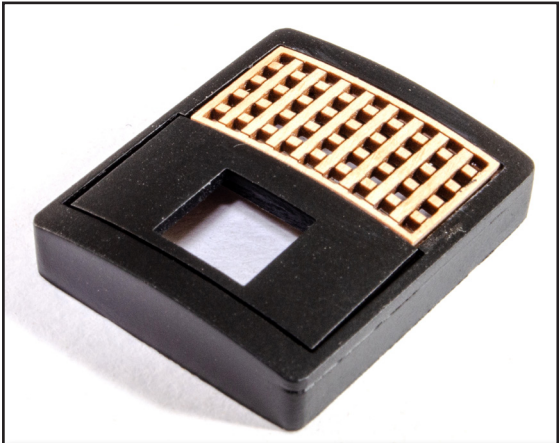

298. The finished forward grate/coaming assembly will look like this when complete.

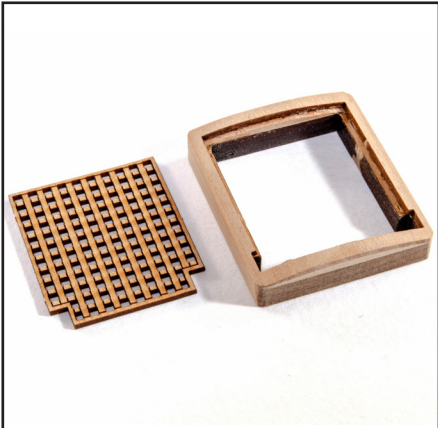

299. This assembly requires grate part 151, found on the 1mm wood sheet.

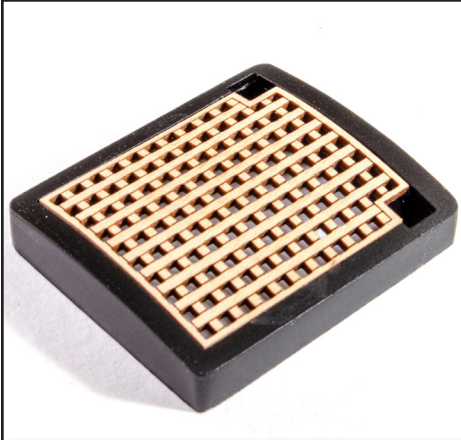

300. The finished assembly will look like this.

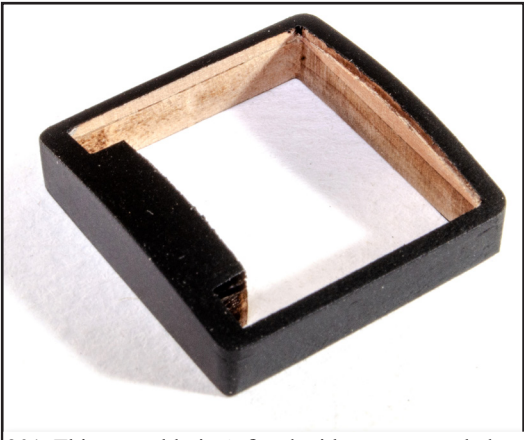

301. This assembly isn't fitted with a grate as a ladder will be used. Paint this black.

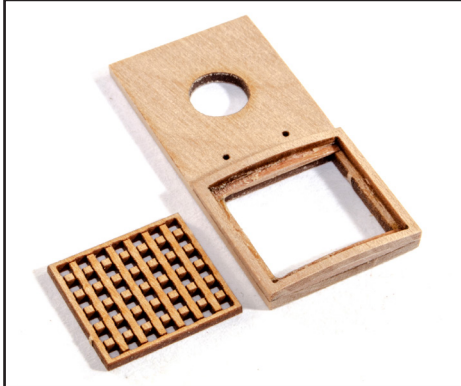

302. Remove part 149 from the 1mm wood sheet.

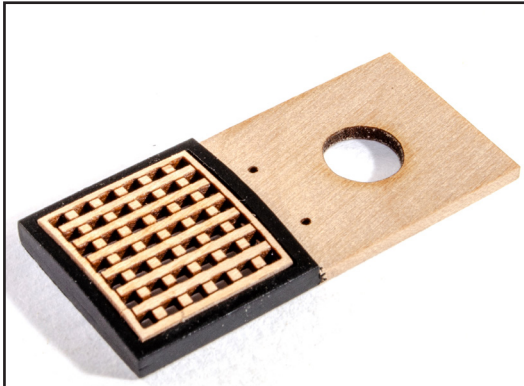

303. Finish this assembly as shown.



304. This last assembly can now be glued to the deck. Use a dowel to ensure that you get the mast hole properly aligned.



305. With that in place, you can now safely add the companionway alongside. Note the orientation of this assembly.

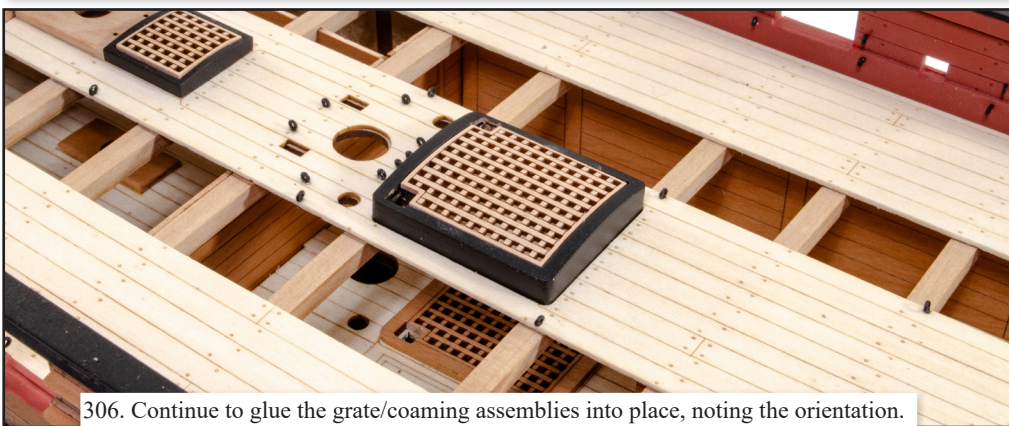

306. Continue to glue the grate/coaming assemblies into place, noting the orientation.



307. Now glue the fore ladderway into place, noting the orientation.



308. We now need to make a ladder for that opening. From the 0.6mm wood sheet, remove parts 78, 79, 80, and 81.



309. Glue two steps into one of the side frames, leave to dry and then glue the other side frame into place, making sure everything is 'square'.



310. Now glue the remaining steps into place and add the engraved sides.



311. The ladder can now be fitted to the ladderway, noting orientation.



312. The stove chimney can now be added, noting that the opening points towards the bow. NOTE: it's a good idea to check the fit into the opening on the corresponding grate/coaming assembly.



313. The grate/coaming can now be fitted.



314. From the 3mm wood sheet, remove both parts 263. From the 1mm wood sheet, remove two parts 157, and 158.



315. Glue parts 157 on either side of 158. When set, add parts 263.



316. This can now be painted red and fitted through the openings in the corner of the fore ladderway, making sure that it plugs into the corresponding holes in the lower deck. NOTE: You only need to paint this assembly red from above the upper deck.

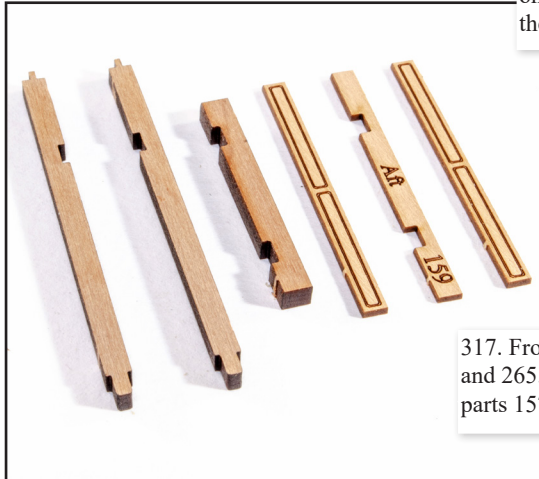

317. From the 3mm wood sheet, remove parts 264 and 265. From the 1mm wood sheet, remove two parts 157, and 159.



318. Assemble posts 264 with the beam 265 sitting into the slots. Ensure the assembly is 'square'. Also assemble the top of the gallows as with the previous gallows you just fitted.



319. Assemble the parts as shown.

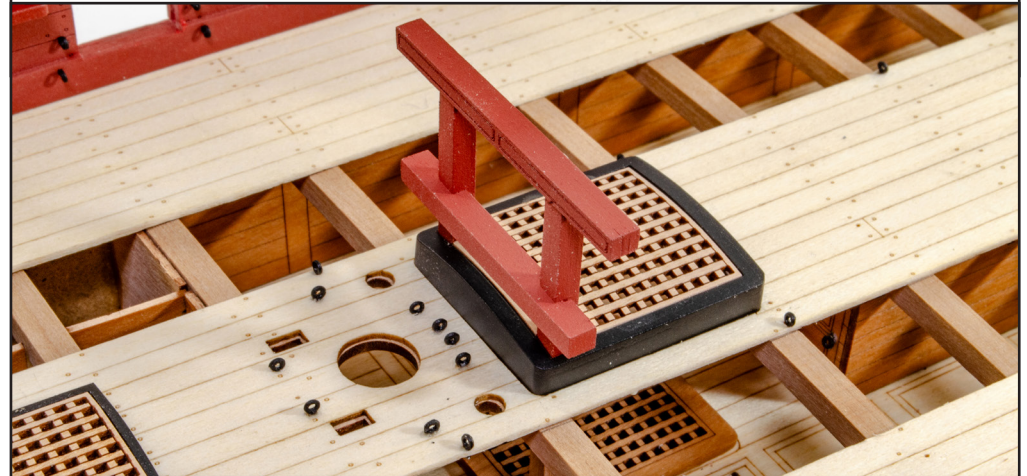

320. This should now also be painted red above deck height, and glued into position as shown, ensuring the bottom of the gallows plugs into the corresponding holes in the deck below.

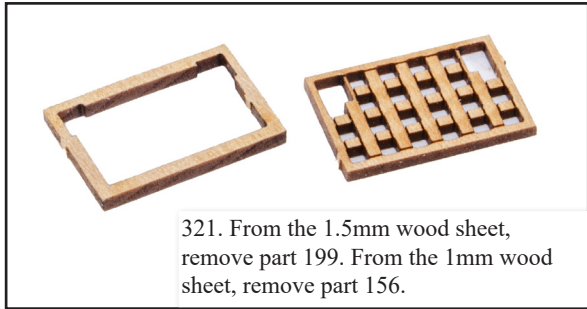

321. From the 1.5mm wood sheet, remove part 199. From the 1mm wood sheet, remove part 156.



322. Assemble as shown.



326. From the 3mm wood sheet, remove both parts 266.

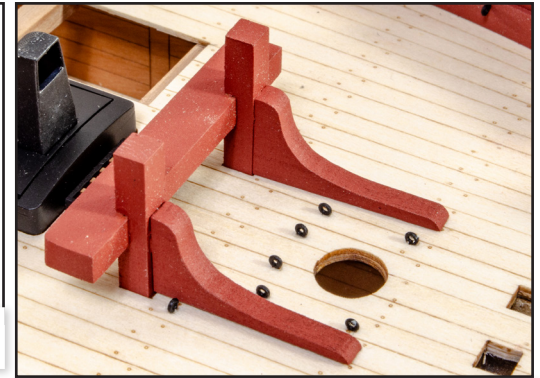

327. Glue those parts to the bits as shown. A tip is to dry fit the bits and then glue parts 266 against them to achieve the correct position. You can then remove the assembly, paint it red, and then glue into position as shown.

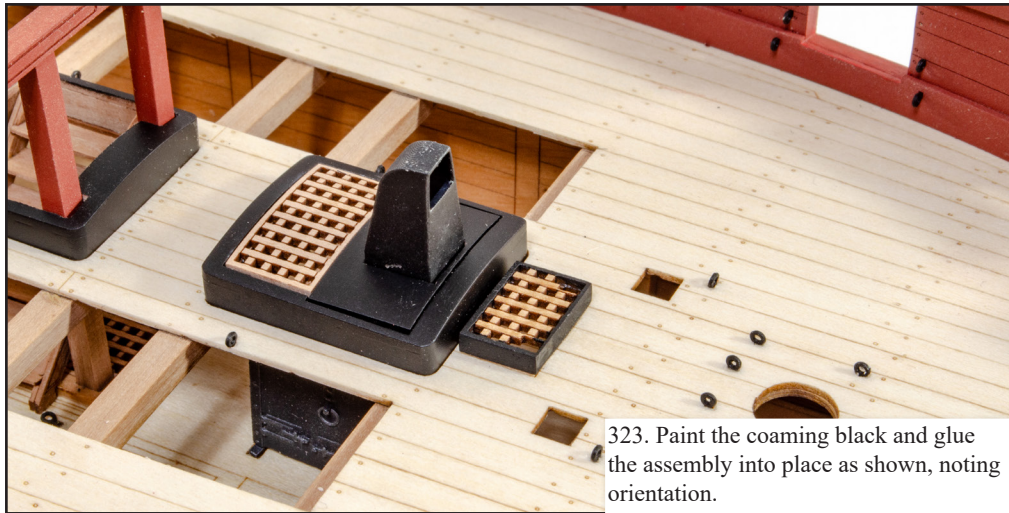

323. Paint the coaming black and glue the assembly into place as shown, noting orientation.

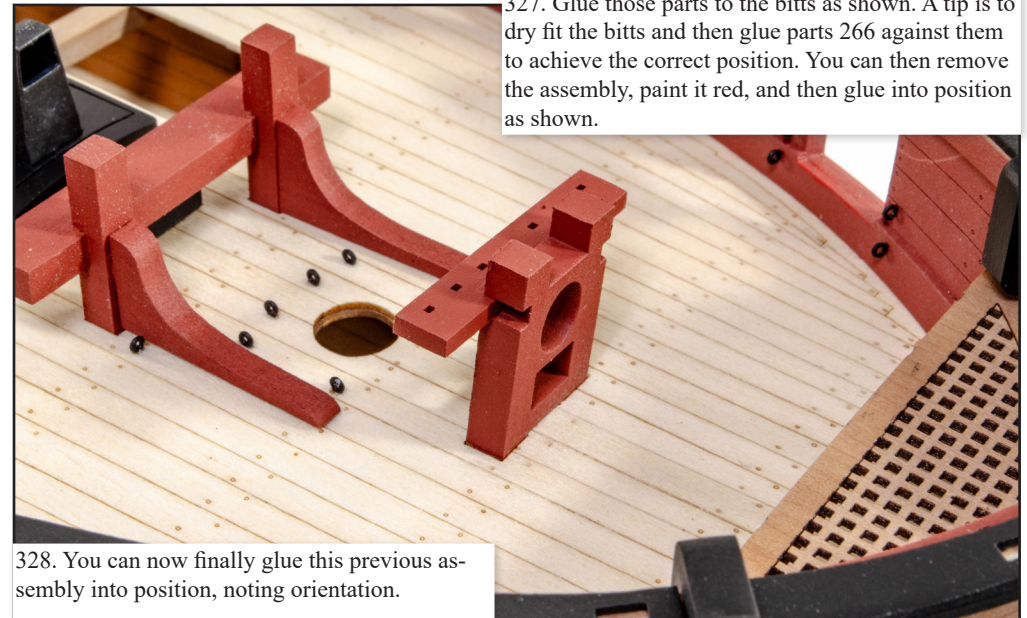

328. You can now finally glue this previous assembly into position, noting orientation.



324. From the 4mm wood sheet, remove parts 273 and 274.



325. Glue together as shown.

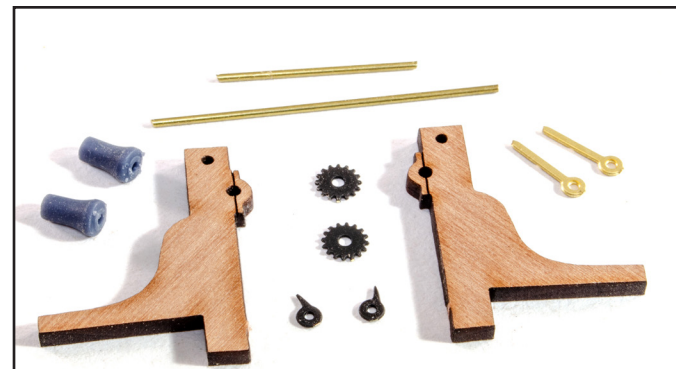

329. From the 2mm wood sheet, remove parts 253 and 254. You will also need the 3D printed winch drums F4. From the 0.4mm PE sheet, remove both parts PE-48, two parts PE-30 and two parts PE-31. You will also need two lengths of 0.8mm brass rod. One should be 19mm long and the other 32mm long.



330. Assemble these parts as per your plan and paint as you see here.

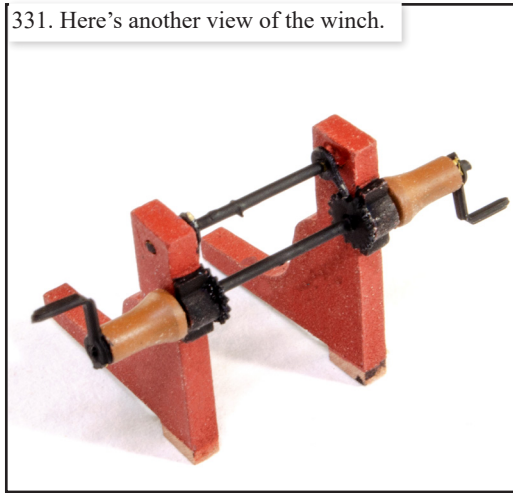

331. Here's another view of the winch.

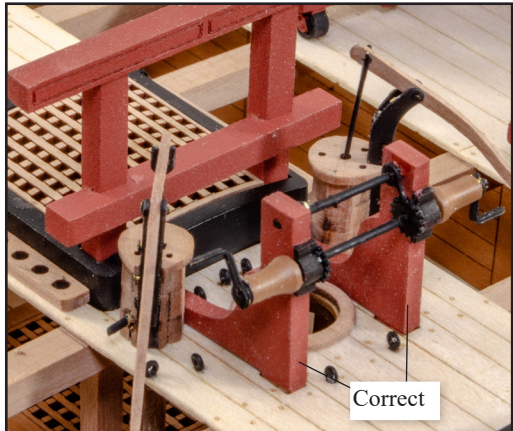

Correct

332. NOW...I always talk about orientation, and here I took the photo with it the wrong way around. Work smart, not like me! When you fit this assembly, make sure it points in the opposite direction. I've included an amended photo so you can see how it looks.

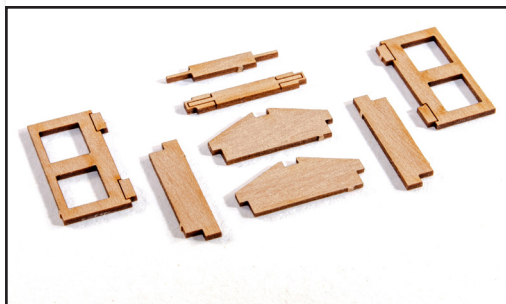

333. From the 1mm wood sheet, remove parts 125, 126, 127, 128, and 129.

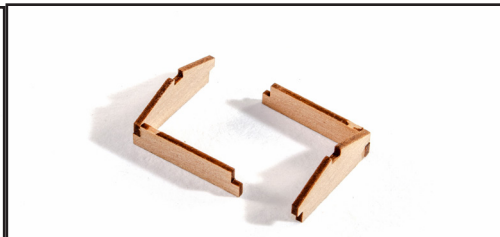

334. Assemble parts 125 and 126 like this...gluing the assembly as halves and making sure the parts are 'square' to each other before finally gluing the two sections together.

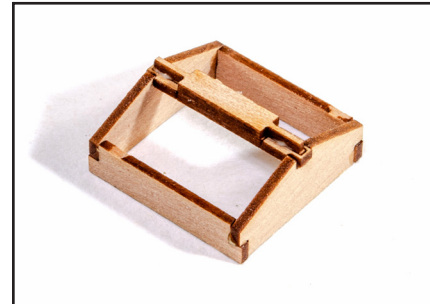

335. Glue 127 into the slots at the top of the assembly, with the engraved side upwards. Now glue 128 on top of that, using the engraved lines to correctly place.



336. We now need to fit the doors to the main body. These can be positioned either open or closed. On our prototype, we posed them in a closed position.



337. Before you fit the doors, glue the windowpanes, parts PE-33 from the 0.4mm PE sheet, into the openings. Now glue the doors to the skylight and then add the PE hinges PE-8 from the 0.2mm PE sheet.

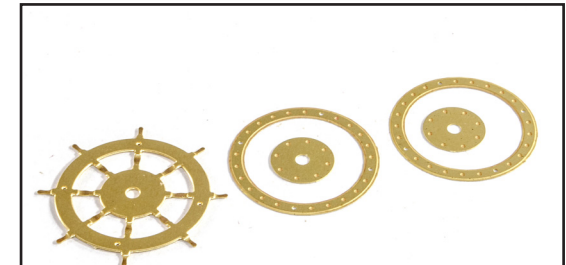

338. We can now build the ship's wheel unit. From the 0.6mm PE sheet, remove part PE-50. From the 0.2mm PE sheet, remove both parts PE-4.



339. Glue together as shown. There are holes in all parts that you can use to align them, along with temporary brass pins.



340. From the 1.5mm wood sheet, remove both parts 208. From the 3mm wood sheet, remove both parts 267. From the 1mm wood sheet, remove both parts 132. You will also need a 13mm length of 2mm dowel.



341. Glue parts 267 together and clean them up. You can now glue parts 132 to each end. It's advisable to use the 2mm dowel to ensure good alignment, but don't glue it in yet.

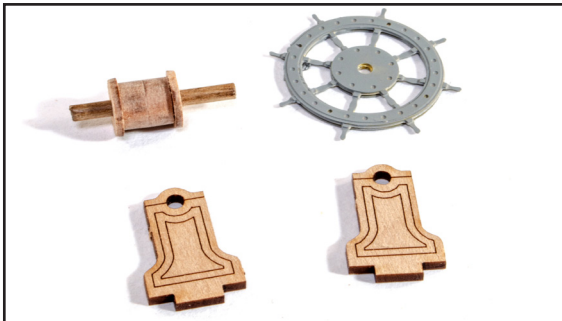

342. Prime and paint the wheel and you're ready to assemble the unit.



343. Add one part 208 to one side of the drum, and then slide the wheel onto the other end, followed by the other part 208. Don't glue anything yet as you can do this when you align to the deck.



344. You can now glue the wheel unit to the deck, noting orientation.



347. The binnacle should look like this when you have assembled these parts.

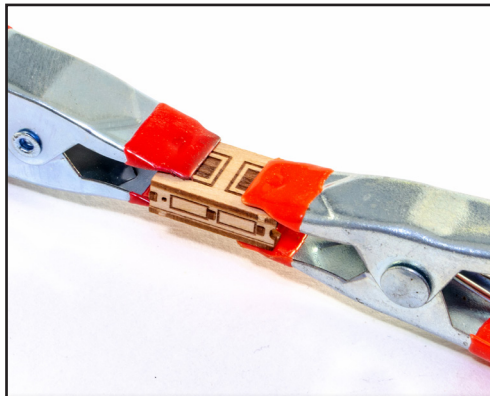

348. Glue the main side parts in place, clamping as you go.

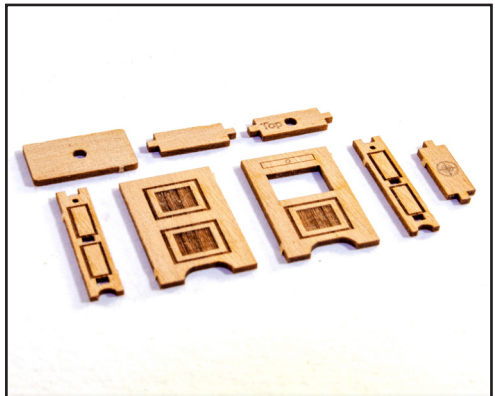

345. From the 1mm wood sheet, remove parts 163, 164, 165, 166, 167, 168, and 169.



346. Slot the inner three parts into one of the side walls. The upper part has the chimney hole, and the middle part has the engraved circle. Please note that the scalloped end of the side walls denotes the bottom of the binnacle. You will also need one of the PE-3 parts from the 0.2mm PE sheet. Paint this and add to the engraved circle on the middle inside part. This is the compass.



349. You can finally add the top panel part 167 and 3D-printed binnacle chimney F-6.



350. Glue the binnacle into place as shown.



351. From the 1mm wood sheet, remove part 130 and fit to the fore mast base as shown. You can use dowel here to ensure perfect alignment.

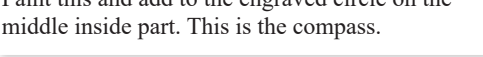

352. From the 0.6mm wood sheet, remove parts 70, 71, 72, and 73. There are parts here for two ladders.

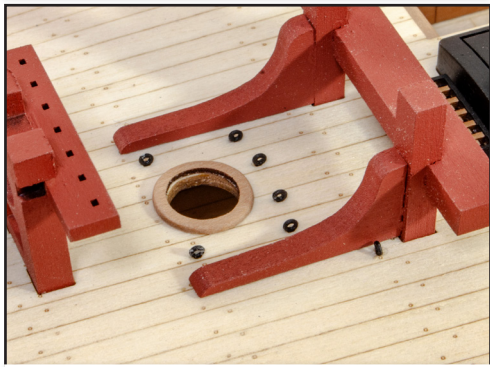

351. From the 1mm wood sheet, remove part 130 and fit to the fore mast base as shown. You can use dowel here to ensure perfect alignment.



352. From the 0.6mm wood sheet, remove parts 70, 71, 72, and 73. There are parts here for two ladders.



353. Build these exactly as before.

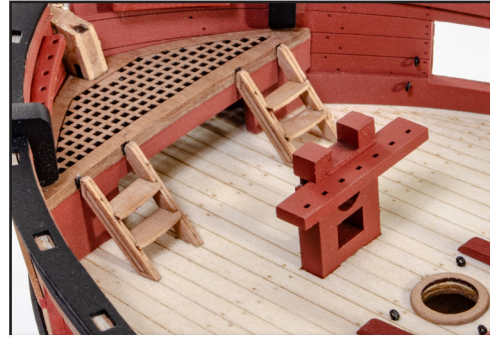

354. Now glue them into position inside the bow area at the points located.



358. From the 0.4mm PE sheet, remove parts PE-27 and PE-28. You will also need a few brass nails.



359. Sandwich one part PE-28 between two parts PE-27, using pins to align the parts and superglue to secure the parts.



355. From the 1mm wood sheet, remove part 131 and fit to the main mast base as shown. You can use wood dowel here to ensure perfect alignment. (Again, please ignore the orientation of that winch!)



360. Cut the brass pins short and glue the metal assemblies to the pump bodies as shown. The metal assemblies have a shoulder on the back. This is what will lean on the top of the pump cap.

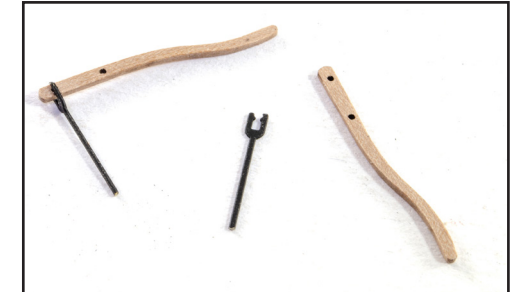

361. From the 0.8mm wood sheet, remove both parts 117. From the 0.4mm PE sheet, remove two parts PE-29. Fit together as shown. You will need to splay out the metal fork a little so the wooden handle will fit within. Carefully push the metal back together when in situ.



356. From the 3mm wood sheet, remove all parts 268. From these you will make the bodies for TWO pumps. Carefully glue them together whilst aligning them on a 3mm dowel length. Ensure the recessed sides are in alignment.

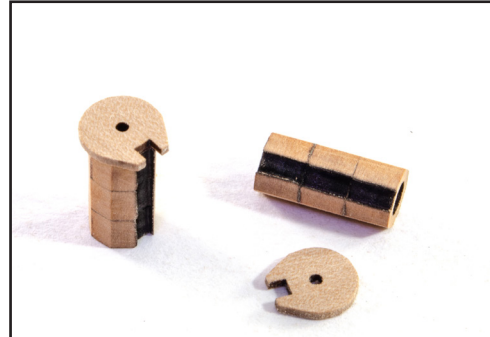

357. To the top of each pump body, glue a part 162, from the 1mm wood sheet. Again, make sure the recess is aligned with those on the pump bodies.



362. Fit the handles to the pumps as shown, using a brass pin to secure. You should clip the pin short when glued into place.



363. Drill a small hole near the base of each pump and attach a small length of 0.8mm brass rod. This is the drain spout.

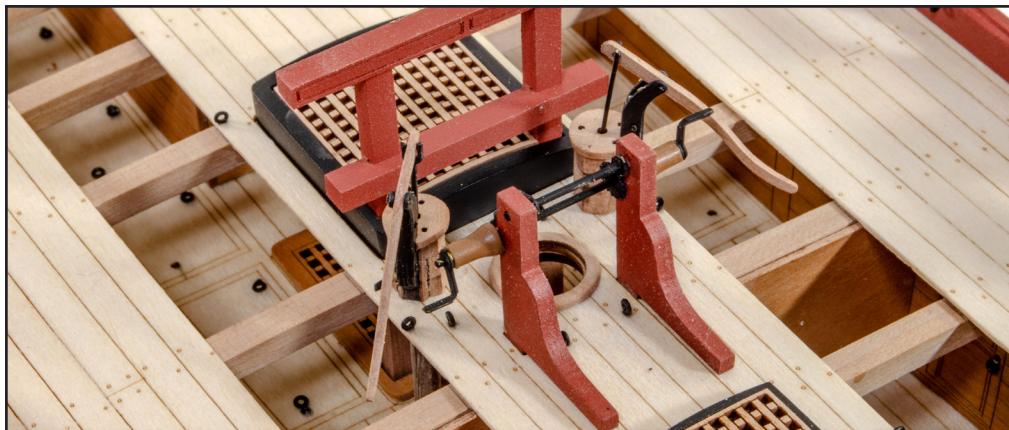

364. Cut two lengths of 3mm dowel 40mm long. Use these to attach the pumps to the deck so that the bottom of the dowel sits into the holes in the lower deck.



365. Capstan time. From the 2mm wood sheet, remove all parts 252. From the 1mm wood sheet, remove parts 143. From the 0.8mm wood sheet, remove part 118.



367. From the 1.5mm wood sheet, remove part 198. From the 0.6mm wood sheet, remove both parts 58.

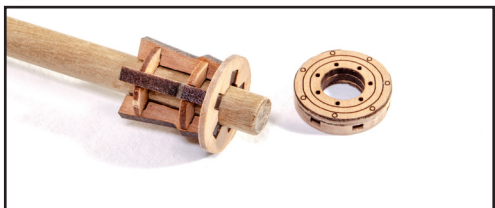

369. Glue that part on top of the drum that you just built.



366. Assemble the parts as shown here, using a length of 6mm dowel to align. Do NOT glue the dowel.



368. Sandwich part 198 between parts 58. Use pins to align. From the 0.8mm wood sheet, remove part 119.



370. Glue the drum to the top of the capstan. Now cut the 6mm dowel so that it's 52mm long. Glue the dowel into the capstan so the top of the dowel is flush with the top of the drum. From the 0.8mm wood sheet, remove part 120. Glue this to the centre top of the capstan.



371. You can now paint the assembly in red.

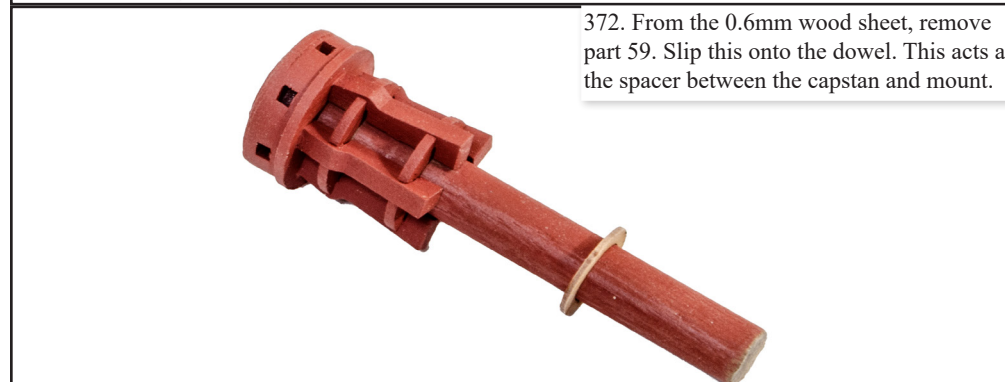

372. From the 0.6mm wood sheet, remove part 59. Slip this onto the dowel. This acts as the spacer between the capstan and mount.



373. The capstan can now be fitted, locating the dowel into the hole in the lower deck.



374. From the 1.5mm wood sheet, remove two parts 222. Fit these into position as shown, using two brass pins.



375. Now glue the stove chimney F-9 into place.



376. On the 1.5mm wood sheet, you will find a series of shot garlands which are specific to their deck locations, adjacent to the various black coamings. Remove these from the sheet and place into positions shown on the plan.



377. From the 2mm wood sheet, remove parts 230, 231, 232, and 233. From the 3mm wood sheet, remove parts 230a.



378. Glue 230a to 230, using brass pins to aid alignment. Also glue parts 232 into the engraved area on the underside of the gun bed.



379. On the sides of parts 231, you will see an engraved slot. Using a 0.8mm drill bit, drill a hole in the middle of that slot, a couple of millimetres deep.

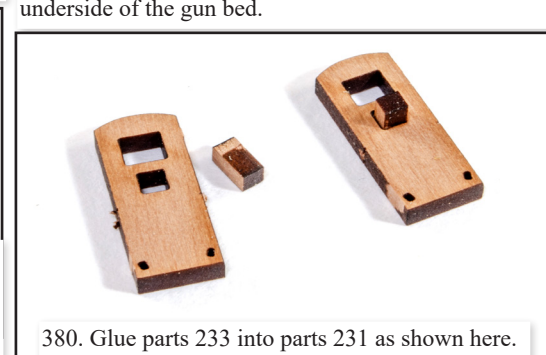

380. Glue parts 233 into parts 231 as shown here.



381. Take the 3D-printed carronade wheels and remove them from their blocks. Use superglue to glue them into the underside of the carronade carts.



382. You can now sand the part flush with the upper side of the carronade carts.



383. Fit the carronade bed to the upper side of the carronade carts, as shown here.



384. Paint the carronade carts in red and paint all the 3D printed carronades themselves (F-1) in a unifying black colour. From the 0.4mm PE sheet, remove all parts PE-16 and PE-17 and fit as shown. This also applies to the eyelets PE-14. When complete, glue the carronades to the carts.

385. Your full armoury of carronades will look like this. Menacing.



386. From the 1.5mm wood sheet, remove parts 223, 224, 225, and 226. There are enough parts here for two cannon. Glue parts 224 to 225 and 226. Don't glue the other side of the cart into place...although you may temporarily use it to make sure the cart is the correct shape.



387. Paint the carts in red and the cap squares in black. Slot the barrel into the half-completed cart, making sure the gun's emblem faces upwards, and then slide and glue the other side of the cart into place.

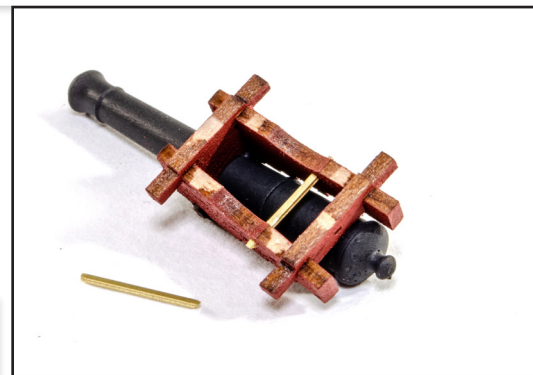

388. From the 0.6mm PE sheet, remove two parts PE-47. Glue into position as shown. Paint black.



389. From the 1.5mm wood sheet, remove parts 227 and paint red. Fit these as shown here.

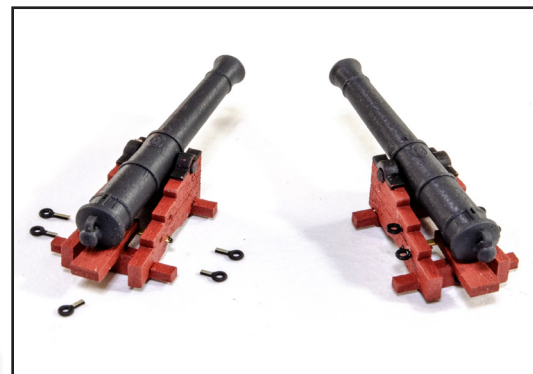

390. Use eyebolts PE-14 to fit into the 5 locations on the cannon carts.



391. From the 1.5mm wood sheet, remove parts 229 and 229. Fit 228 to the front axles of the cart, and 229 to the rear axles.



392. The finished guns should look like this.



394. Harpy is now looking very handsome. Catch a few moments to admire your work.



393. All the cannon and carronades can now be fitted to the deck as shown. Note that the forward two gunports are unoccupied.

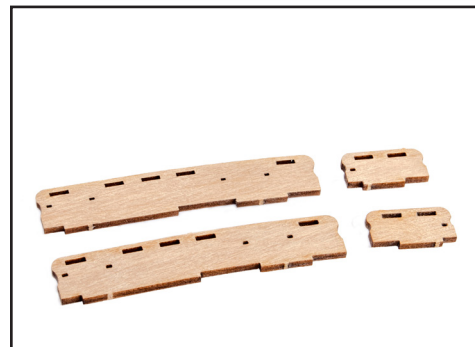

395. From the 1.5mm wood sheet, remove both parts 210 and 211.



396. Glue into position in the slots on the outer hull.

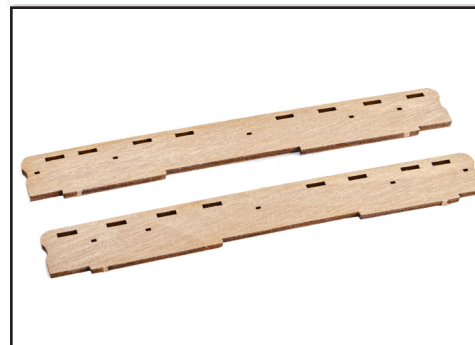

397. From the 1.5mm wood sheet, remove both parts 212.

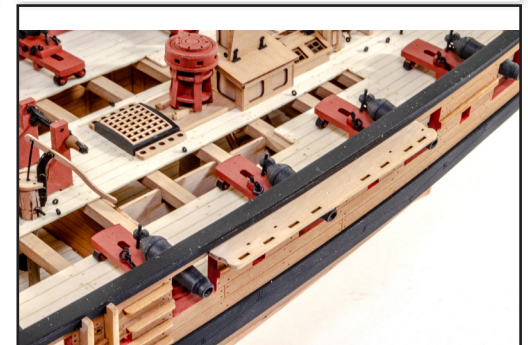

398. Glue into position in the slots on the outer hull.



399. From the 2mm wood sheet, remove all parts 241. From the 4mm wood sheet, remove both parts 275. Glue into place as shown here and on the plans.



400. Here you see those timberheads installed on the rear gunwales.



401. From the 0.6mm PE sheet, remove parts PE-54. Install these into all of the belaying pin racks.

402. Harpy has now taken another leap in appearance.





403. From the 2mm wood sheet, remove part 251. From the 0.6mm wood sheet, remove parts 251L and 251R.

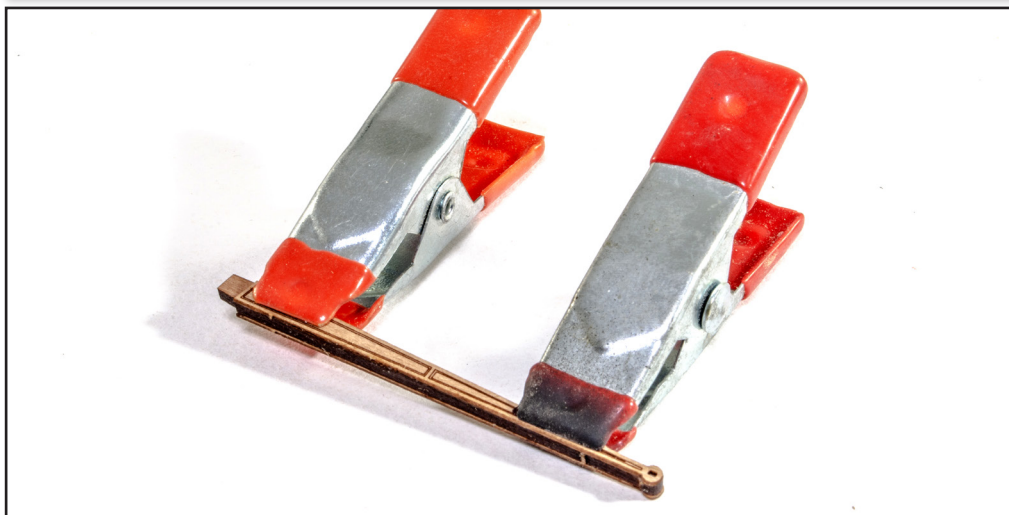

404. Glue the engraved parts to either side of the 2mm part, and clamp until set.



405. When set, remove any laser char from the edges.



406. This assembly is now glued into place onto the top of the rudder, and then rigged as per the plan sheet. Here you can see this rigged.



407. We now need to add the deadeyes to the channels, using the PE strips. From the 0.4mm PE sheet, remove all parts PE-16 and PE-22. You will also need your 5mm and 3mm deadeyes. Take the PE parts and splay them with pliers or a suitable tool. Pop the deadeye into the part and then squeeze the PE back together again. We find it best to prime and pre-paint these parts before assembly.

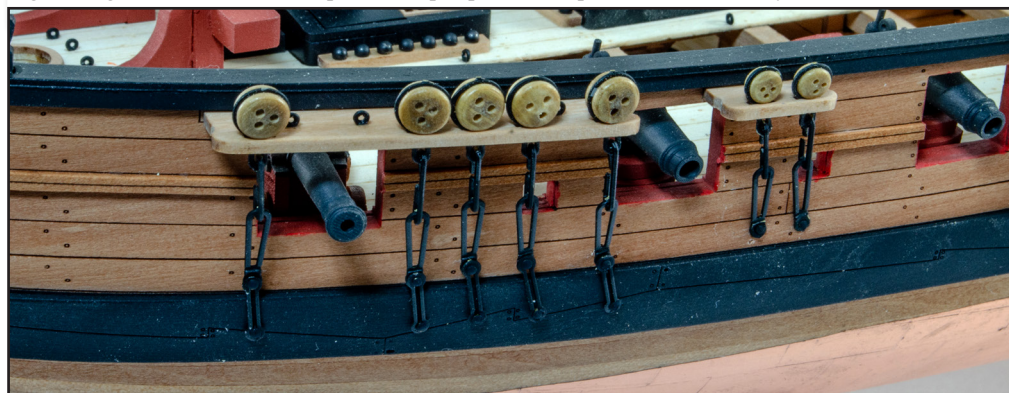

408. These assemblies now need to be slipped into the holes on the channel, noting specifically where the 5mm and 3mm deadeyes need to fit. From the 0.4mm PE sheet, remove all the chainplate parts PE-19, PE-20, PE-21, PE-23, and PE-24, putting them into tubs for each specific part number. Now follow the plan sheet and add these chainplate links to the deadeye assemblies and securing to the hull using brass pins. From the 0.4mm PE sheet, also remove parts PE-14 and glue these eyelets to the channels as seen here and on plans. We find it best to prime and pre-paint these parts before assembly

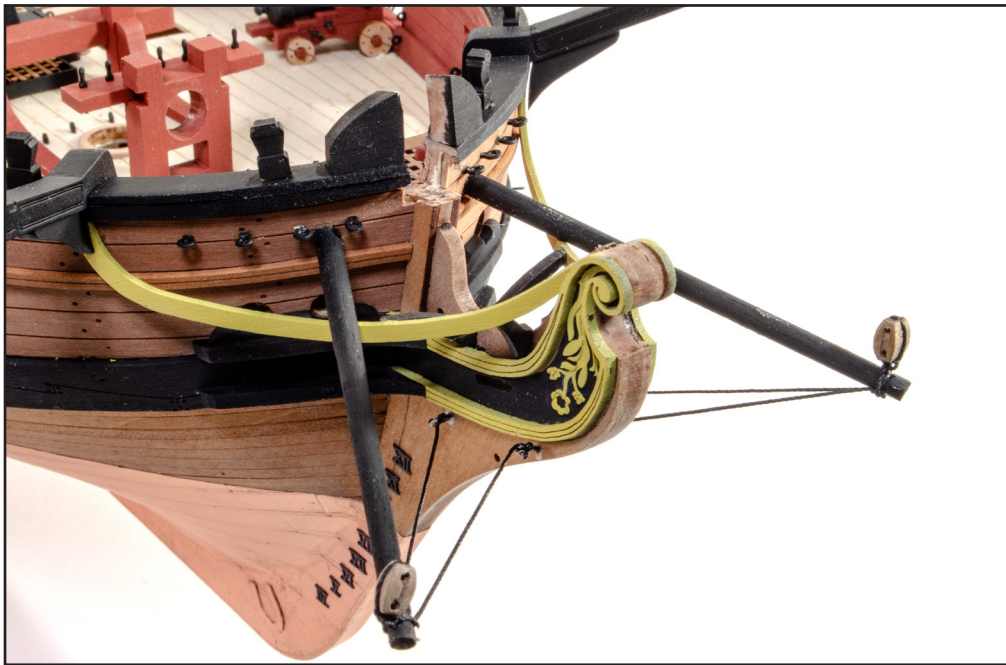
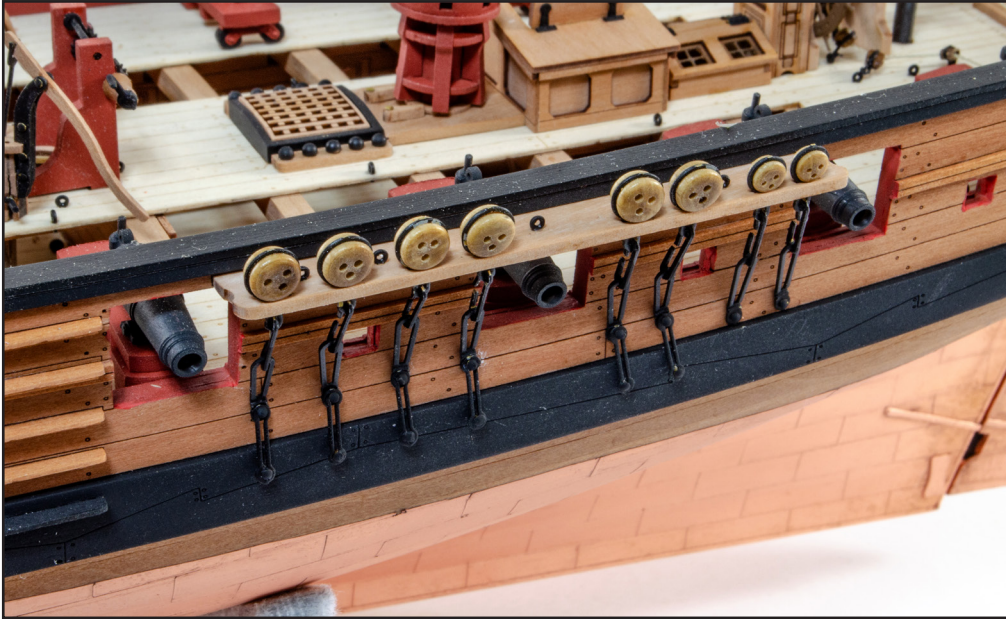

409. The boomkins now need to be added. Follow your plan to make these parts and secure them to the hull via a brass pin, for strength. You can now rig them as shown, to the hull, adding the 5mm single blocks.



410. After building your 22ft Cutter as shown on the plan, you can then add this to the deck using the cradle parts 262 and 262, found on the 2mm wood sheet. You will also need some eyelets PE-14, found on the 0.4mm PE sheet. Use 0.25mm natural thread to lash the boat to the cradles.

411. HMS Harpy will now look very much like this.





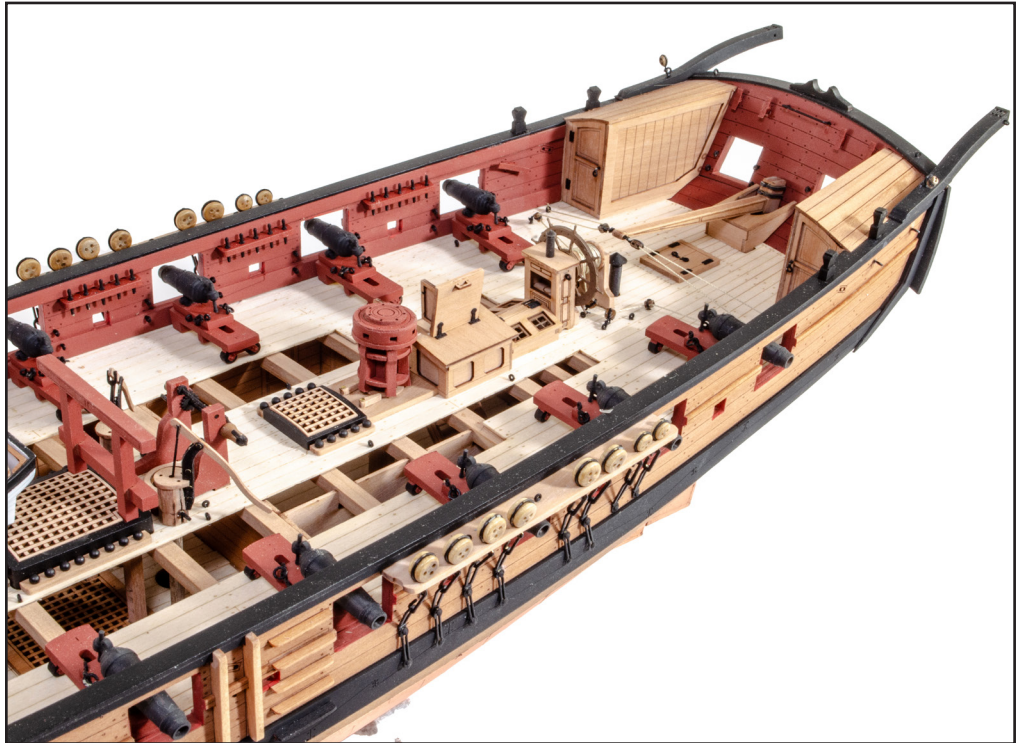
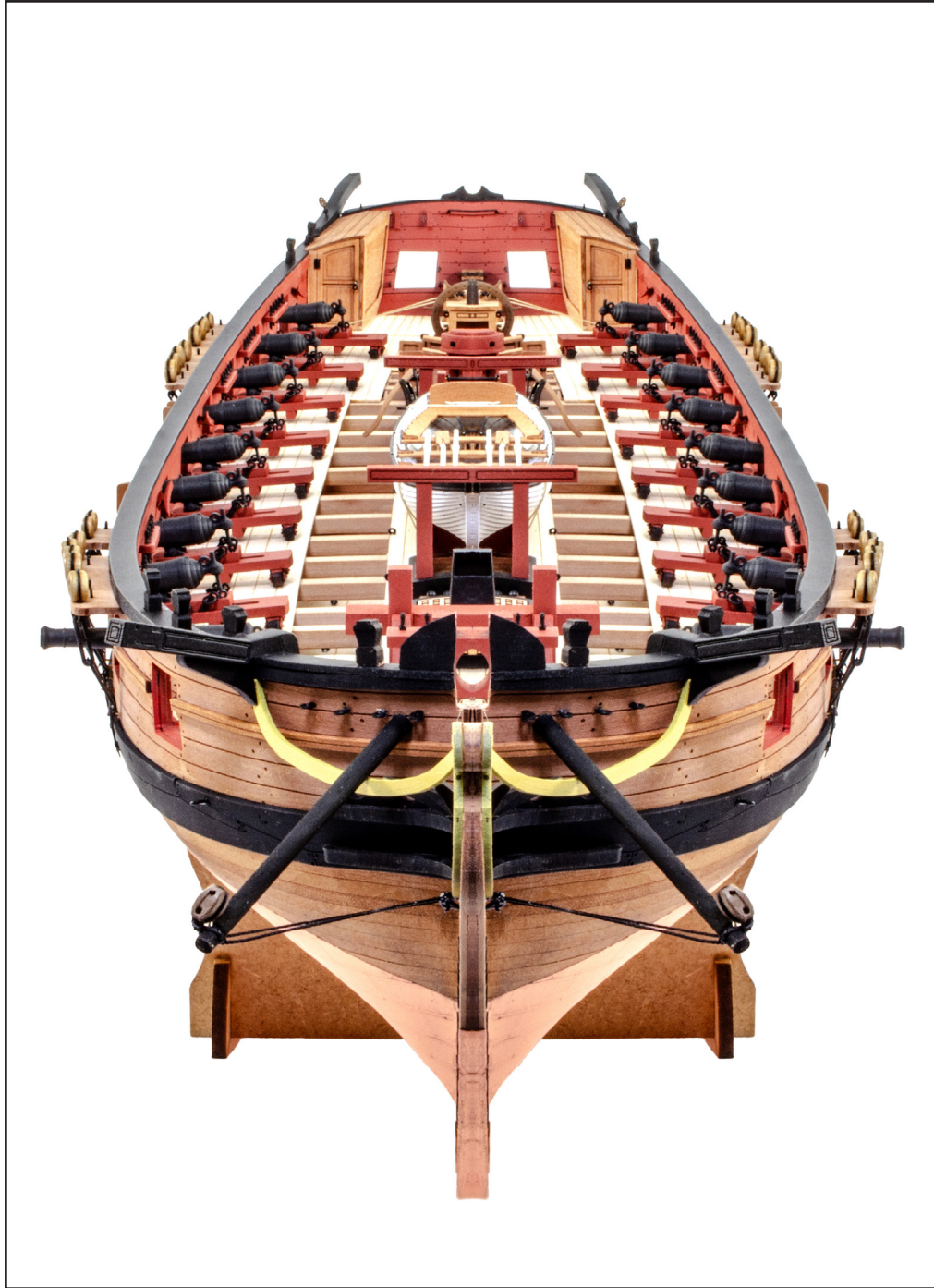



412. It's now time to build the bowsprit. Use your plan to cut the three dowel sections needed for this assembly. You will also need part M35 from the 4mm wood sheet.



413. Using your plan as reference for dimensions, slightly taper the thickest dowel and then remove a section of the dowel into which this part M11 can be fitted. This part can be located on the 1mm wood sheet.



414. With this glued into place, you can now also add part M35. You WILL need to internally chamfer the holes on this part so it can attain the correct angle in relation to the dowel. ALWAYS check against your plans. From the 1mm wood sheet, remove part M12, and glue into place as shown, checking the position.

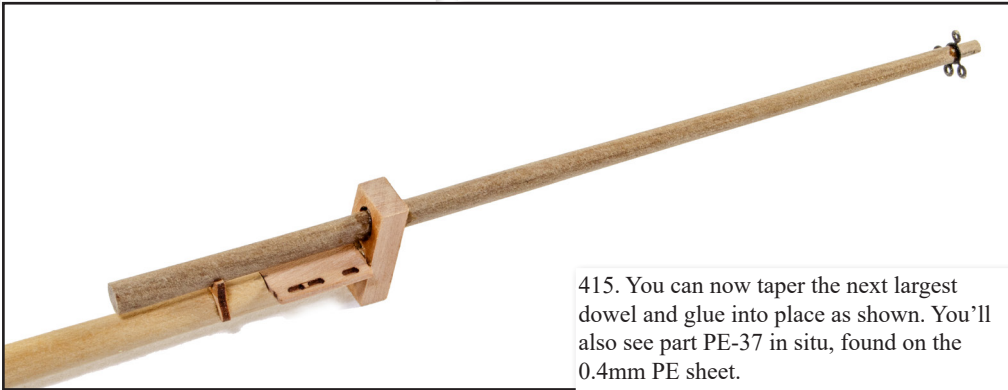

415. You can now taper the next largest dowel and glue into place as shown. You'll also see part PE-37 in situ, found on the 0.4mm PE sheet.

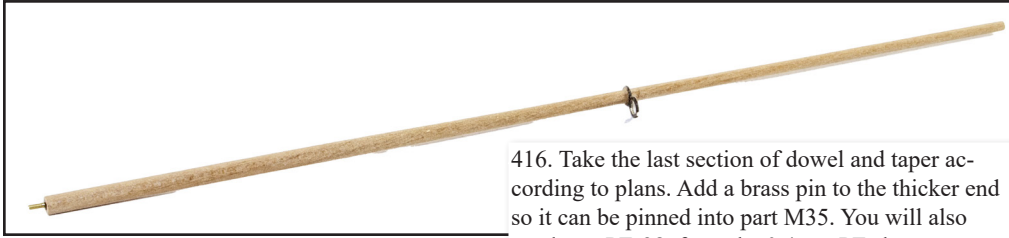

416. Take the last section of dowel and taper according to plans. Add a brass pin to the thicker end so it can be pinned into part M35. You will also need part PE-38, from the 0.4mm PE sheet.



417. Assemble the parts as shown. You should also now bevel the top and bottom of M35 so they flow with the angle of the bowsprit parts.

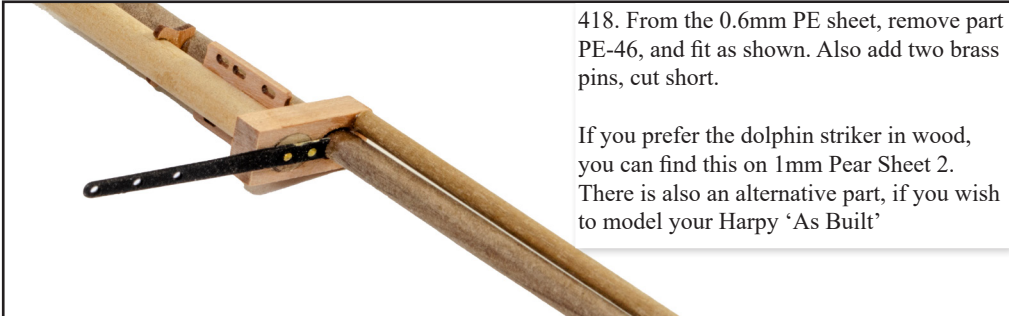

418. From the 0.6mm PE sheet, remove part PE-46, and fit as shown. Also add two brass pins, cut short. If you prefer the dolphin striker in wood, you can find this on 1mm Pear Sheet 2. There is also an alternative part, if you wish to model your Harpy 'As Built'



419. Now add the remaining wooden parts for this, as shown. These are parts M1 and M36 from the 1mm wood sheet.



420. Your bowsprit should now look like this.



421. Paint the section in black as shown and then finally add the various rigging blocks and deadeyes to complete this assembly.

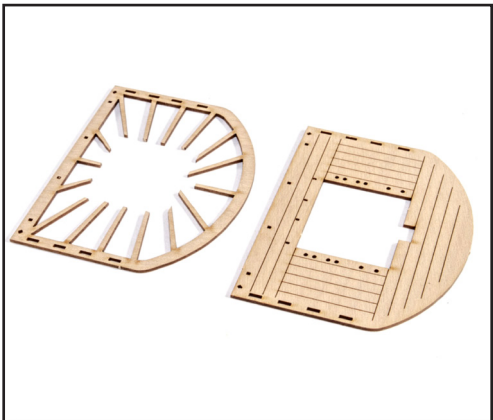

422. From the 1mm wood sheet, remove parts M6 and M7.



423. Glue together as shown, clamping until set. This is the main mast's 'mast top'.



424. From the same wood sheet, remove parts M3 and M4.



425. Glue together as shown, clamping until set. This is the fore mast's 'mast top'.



426. From the 2mm wood sheet, remove parts M27, M28, and M29. From the 3mm wood sheet, remove part M30.

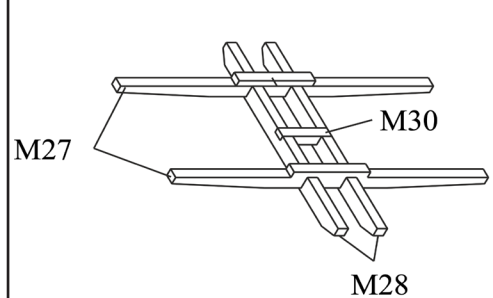

427. Glue together as shown here on the plan sheet. This is the main mast's trestle tree.



428. From the 2mm wood sheet, remove parts M24, M25, and M29. From the 3mm wood sheet, remove part M30.

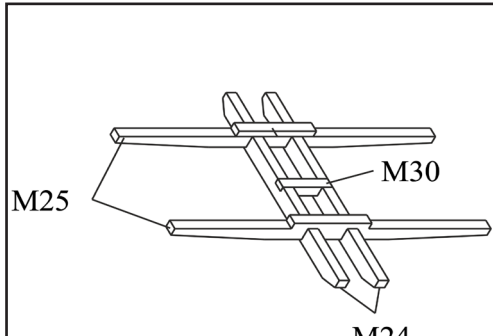

429. Glue together as shown here on the plan sheet. This is the fore mast's trestle tree.

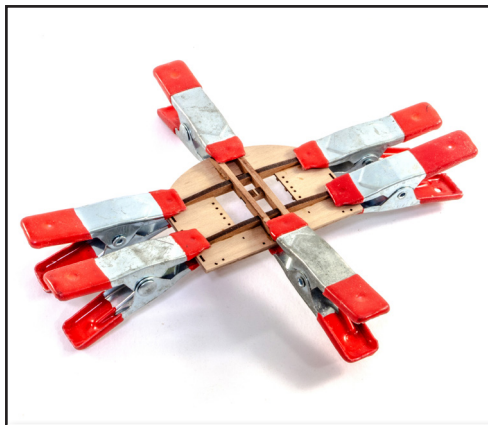

430. Take each trestle tree assembly and glue to the corresponding mast top assembly as shown. Clamp until dry.

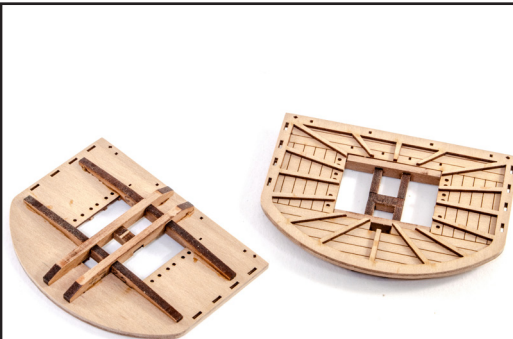

431. The mast top assemblies will now look like this.



432. In turn, cut the three main mast section dowels for both masts, making sure you temporarily label them as per mast. NOTE: the upper two sections of both masts are identical. It's only the lower sections which vary in length, so assembly of these is almost. The main mast is raked slightly aft, and you will need to ensure the mast top and top mast cross trees are angled as per plan so they are level to the waterline.



433. The first part of building the masts involves adding a 0.8mm deep flat edge to opposite sides of the lower section, as per plan. It's up to you how you do this. I made a jig for this, shown here.



434. The upper part of this area now needs to be shaped as per plan, so it will allow the mast top to be slid comfortably over it, but not too loose.

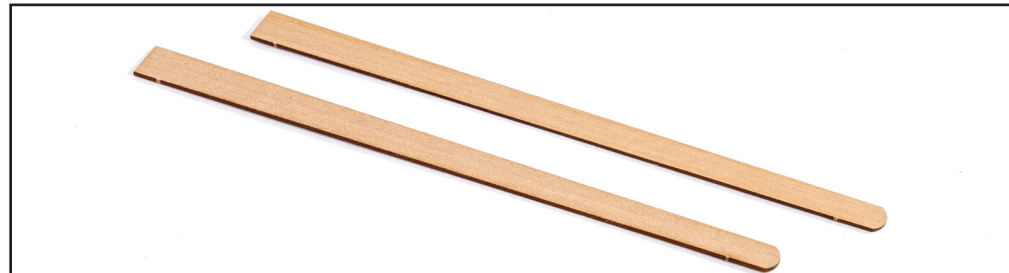

435. From the 0.8mm wood sheet, remove parts M19 (for main mast) and parts M17 if you are building the fore mast.



436. Glue to the corresponding lower mast sections as shown.

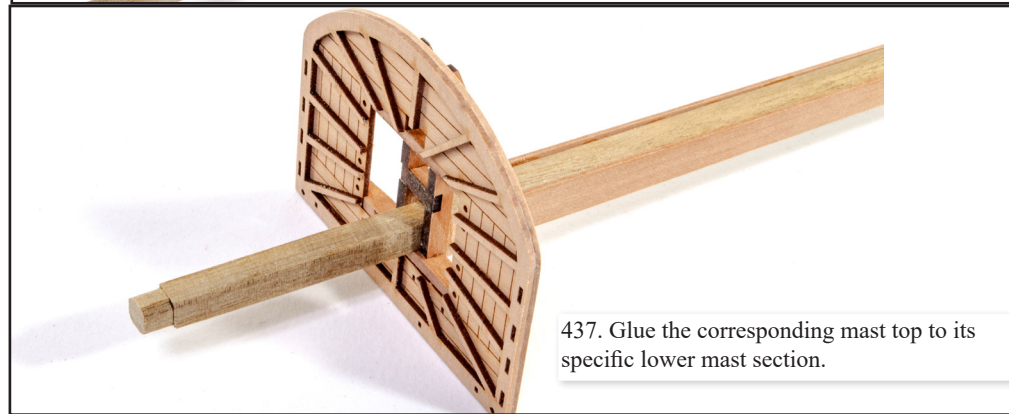

437. Glue the corresponding mast top to its specific lower mast section.



438. From the 0.8mm wood sheet, remove parts M16R and M16L (for the main mast) and M15R and M15L for the fore mast.

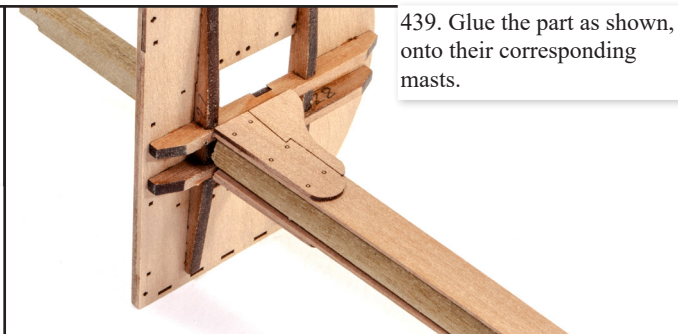

439. Glue the part as shown, onto their corresponding masts.

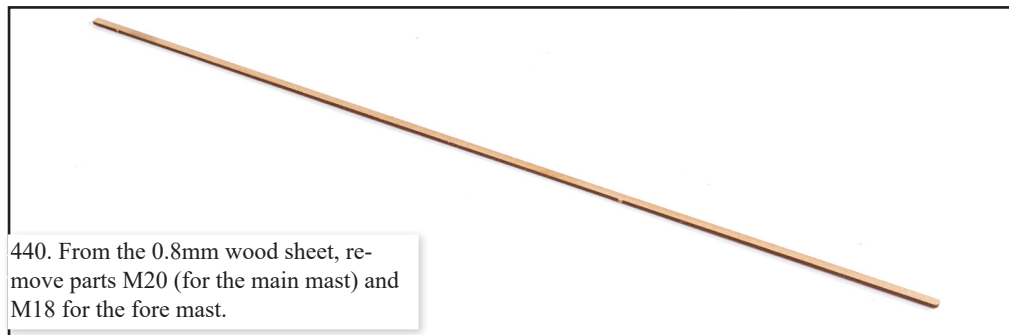

440. From the 0.8mm wood sheet, remove parts M20 (for the main mast) and M18 for the fore mast.

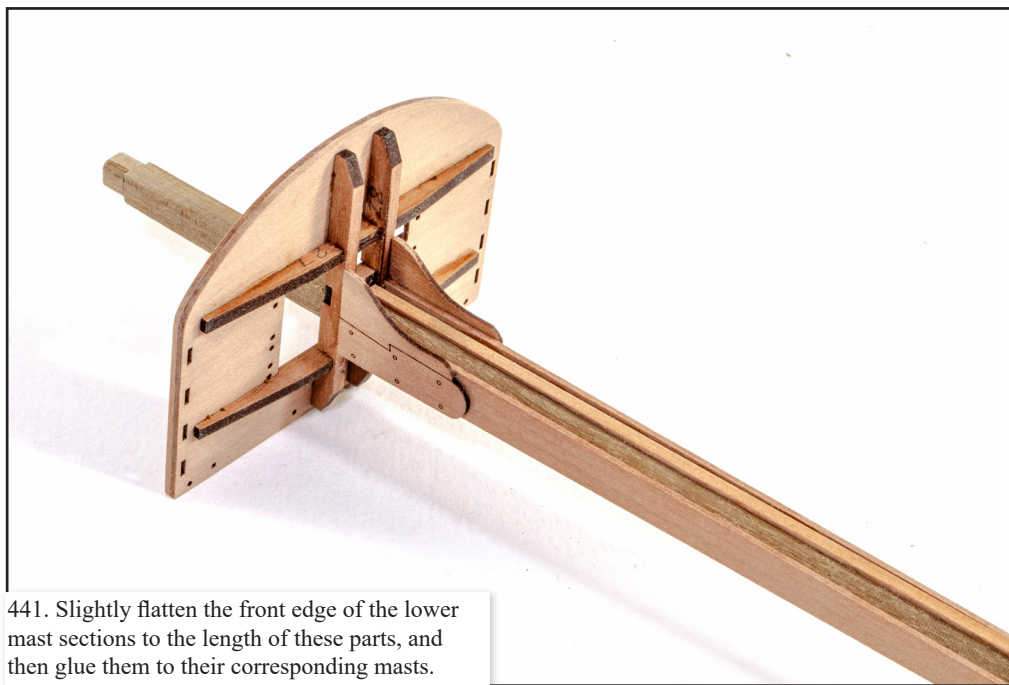

441. Slightly flatten the front edge of the lower mast sections to the length of these parts, and then glue them to their corresponding masts.



442. Take the parts M29 that you removed earlier...

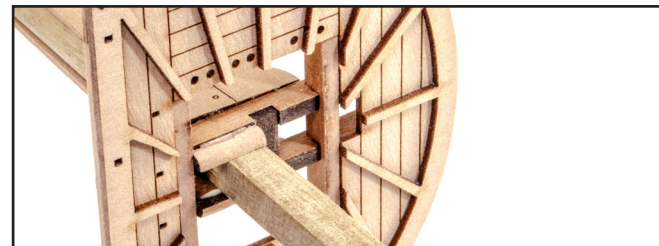

443. ...then shape and glue them into place as shown here. These are the 'Bolsters' for the shrouds.

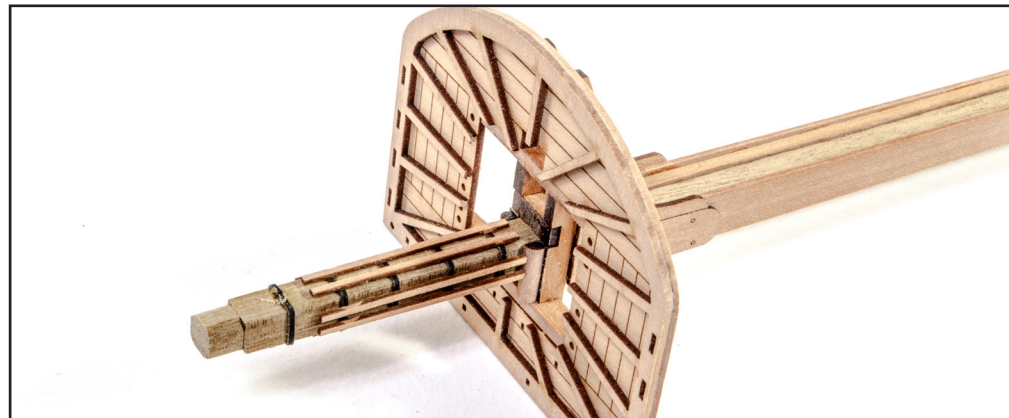

444. Add the laser cut black paper bands As-3, and glue them to the mast section as shown. From the 0.6mm wood sheet, remove parts M37 (for the main mast) and M36 for the fore mast. Glue into their positions on the corresponding masts, as shown here.



445. From the 0.6mm PE sheet, remove part PE-44. From the 2mm wood sheet, remove parts 22. These parts are for the main mast crossstrees.

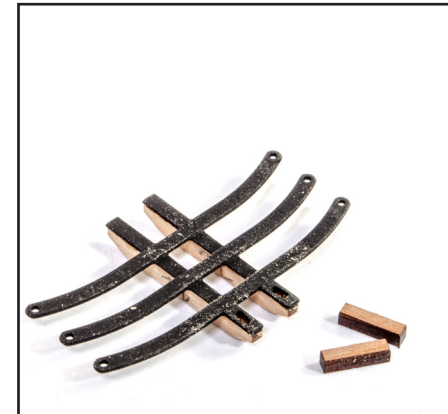

446. Glue these to the underside of the PE. You will also now need parts M26 from the 2mm wood sheet.



447. Shape as shown on plan and glue into place. Now drill a 0.5mm hole through the holes in the PE, so they extend through to the other side of parts M22. Create the same assembly for the fore mast cross trees, using parts M21, M26, and PE-45.

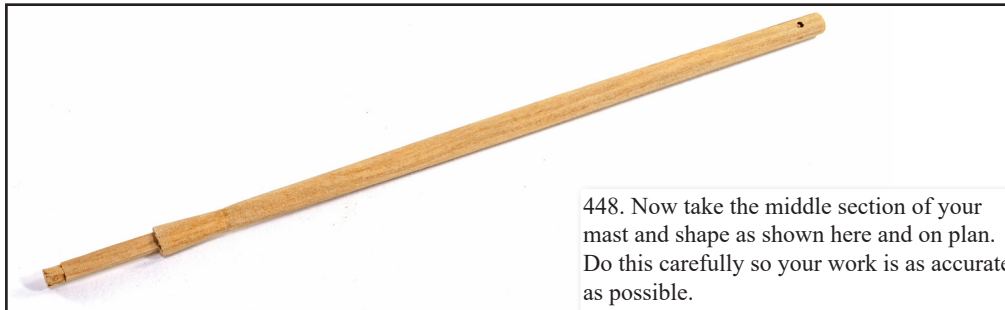

448. Now take the middle section of your mast and shape as shown here and on plan. Do this carefully so your work is as accurate as possible.

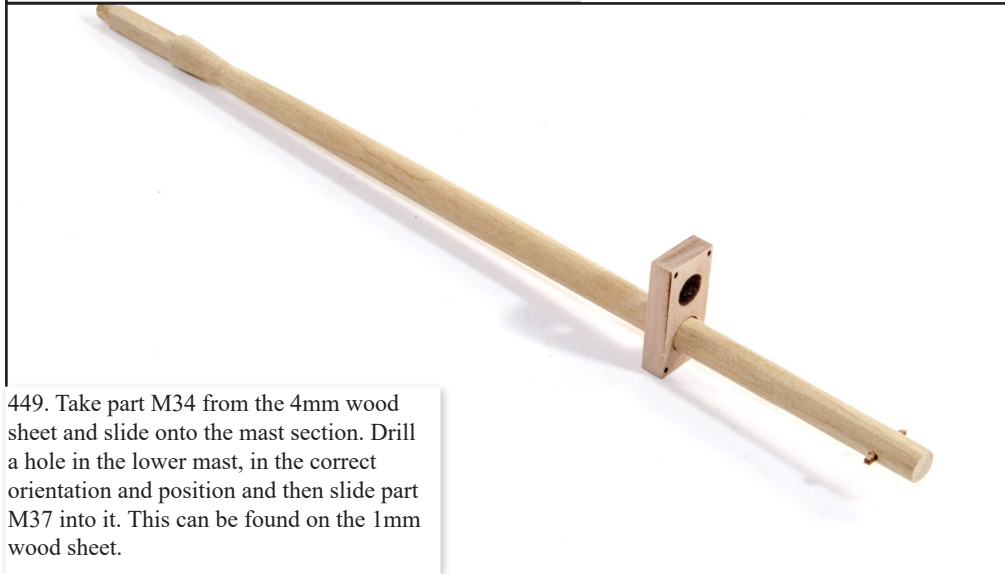

449. Take part M34 from the 4mm wood sheet and slide onto the mast section. Drill a hole in the lower mast, in the correct orientation and position and then slide part M37 into it. This can be found on the 1mm wood sheet.

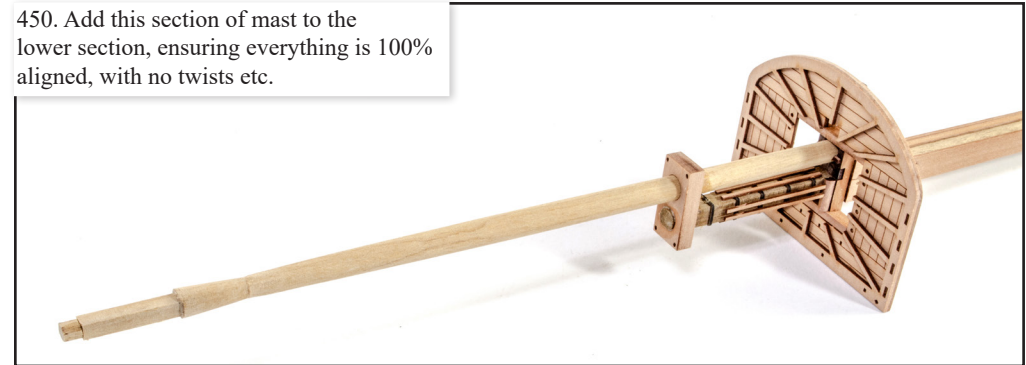

450. Add this section of mast to the lower section, ensuring everything is 100% aligned, with no twists etc.

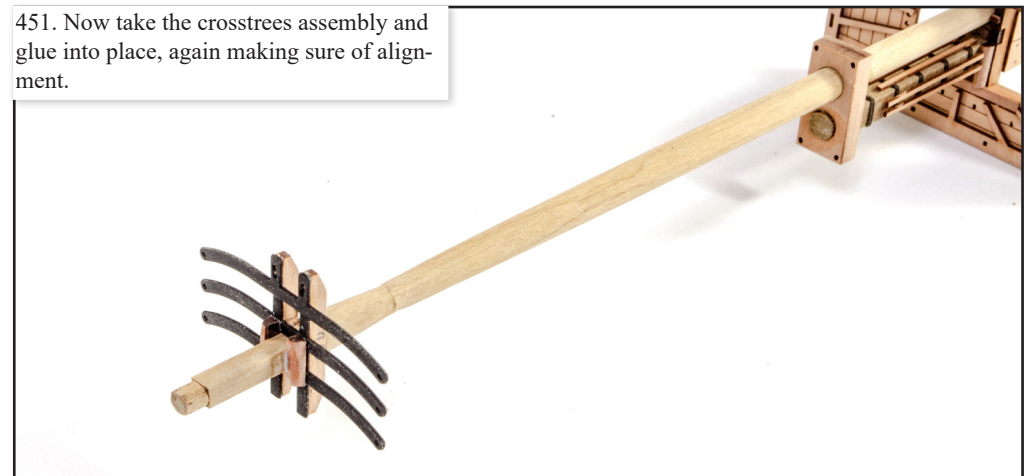

451. Now take the crosstrees assembly and glue into place, again making sure of alignment.

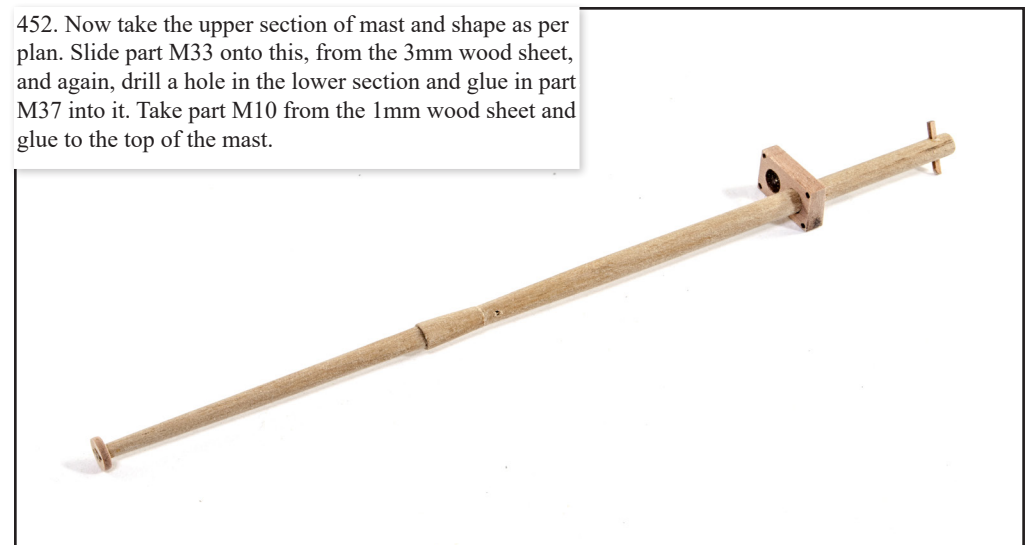

452. Now take the upper section of mast and shape as per plan. Slide part M33 onto this, from the 3mm wood sheet, and again, drill a hole in the lower section and glue in part M37 into it. Take part M10 from the 1mm wood sheet and glue to the top of the mast.

453. Now glue this mast section into place, ensuring alignment and orientation.



454. The main mast will now have parts M13 and M14 added to it, from the 0.8mm wood sheet. Also, fit part M9, from the 1mm wood sheet. The fore mast will only have part M9 fitted.

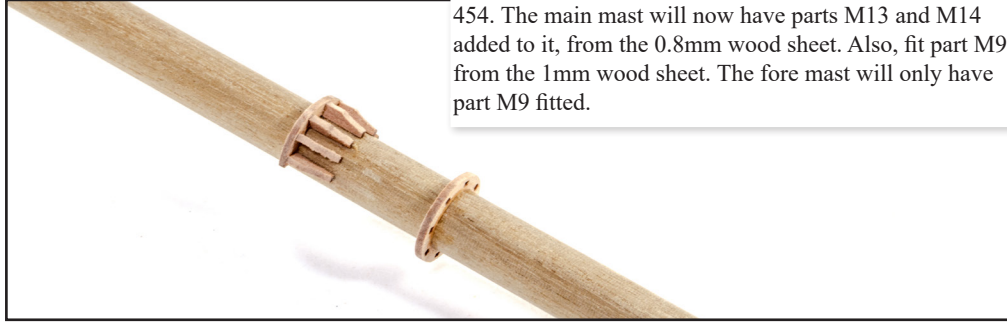

455. Add parts M23 from the 1.5mm wood sheet.

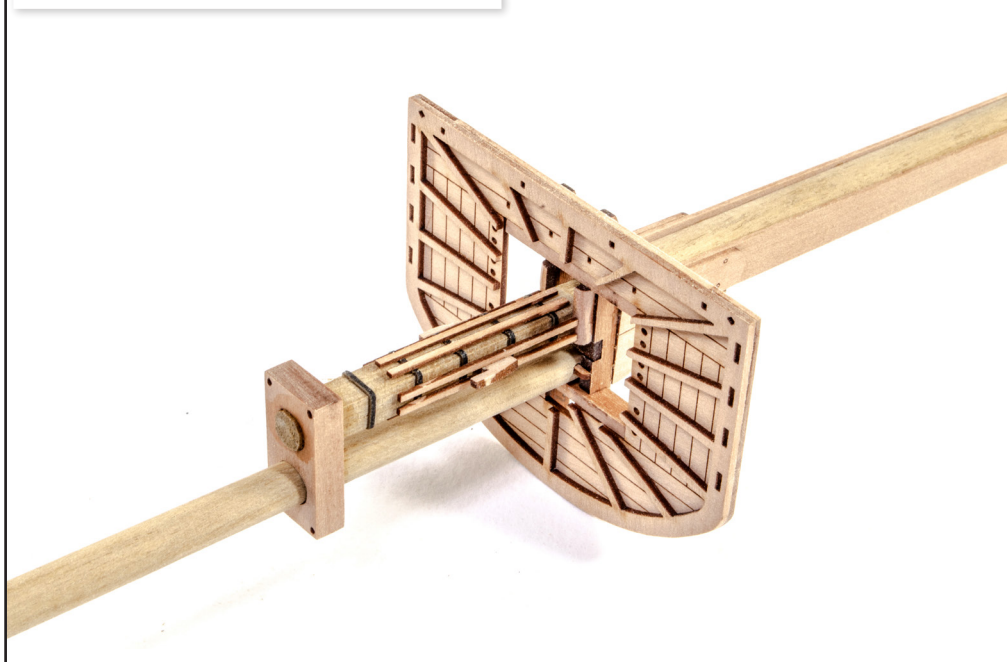

456. Now add parts M1 from the 1mm wood sheet.

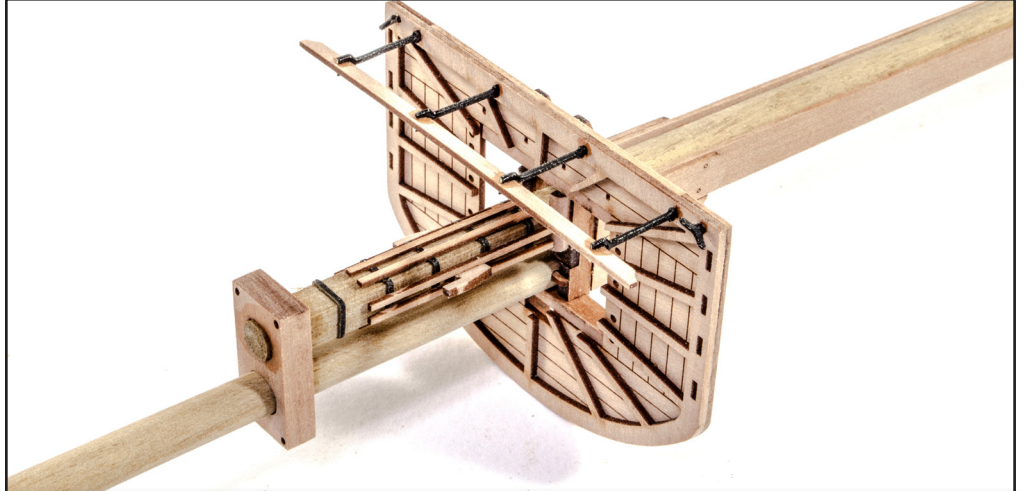

457. From the 0.6mm PE sheet, remove parts PE-52. For the main mast, remove part M8 from the 1mm sheet (part M5 for the fore mast). Glue the stanchions and rail into position on each mast top. Also glue in parts PE-55 from the 0.6mm PE sheet.



458. Paint and varnish the masts as shown and also add the black paper bands to the lower sections. Fit out the masts with their various blocks.



459. Your masts should now look like this.

460. Glue both masts into place on Harpy, checking the alignment.





461. Cut to length a section of 4mm dowel as per plan, and also take part M32 from the 3mm wood sheet. Shape and assemble these as shown on your plans, adding parts M2 from the 1mm wood sheet. Also add eyelet PE-14 from the 0.4mm PE sheet.

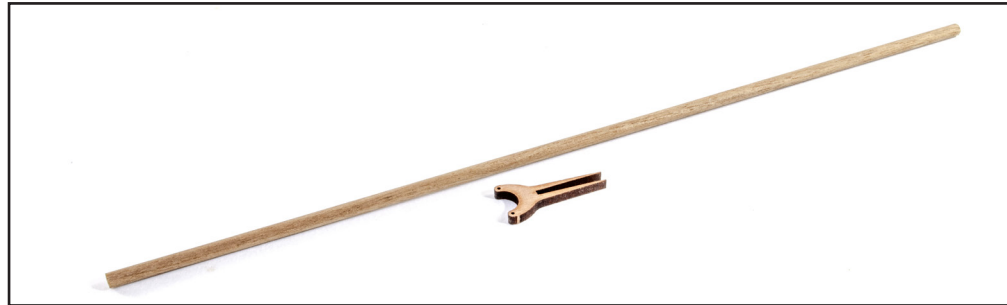

462. Cut to length a section of 4mm dowel as per plan, and also take part M31 from the 3mm wood sheet. Shape and assemble these as shown on your plans, adding parts M2 from the 1mm wood sheet. Also add part PE-55 from the 0.6mm PE sheet.



463. The finished timber work will look like this.



464. Paint and finish these as shown here and on your plans.



465. We'll now show how to build the mast yards. These are quite generic instructions and apply in some degree to all yards. Firstly, cut all six dowel lengths from the 6mm and 4mm diameter dowels. Shape/taper each length as shown on your plans. Now for each one, fine the centre and add a cut off brass pin. This will be used to secure the yard to the mast when the time comes. Glue parts M23 from the 1.5mm wood sheet into place as shown here, for both of the larger of the two assemblies. For the smallest yards, use part M2 from the 1mm wood sheet.



466. For the largest of the yard assemblies, you will need parts PE-12 and PE-13 from the 0.2mm PE sheet; PE-42, PE-43, PE-40, and PE-41 from the 0.6mm PE sheet. Refer to your plans for the placement of each of these parts on the larger yard assemblies. You will also need some black card, cut into 1mm strips. Parts M1 and M2 will also be needed, from the 1mm wood sheet.

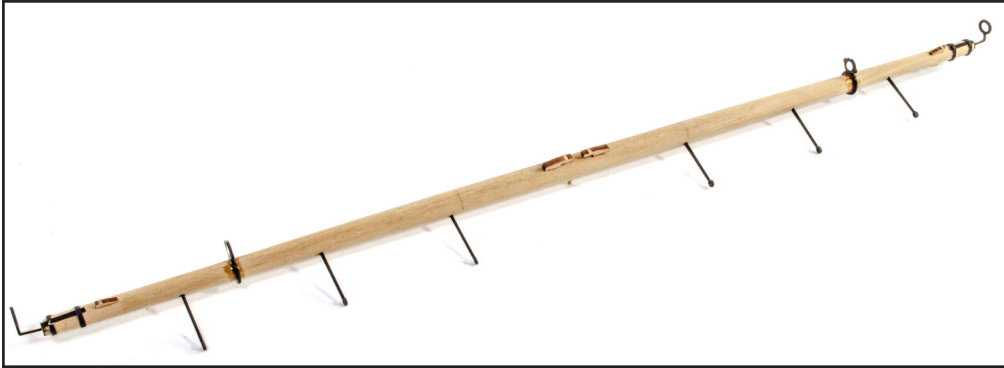

467. Now add parts PE-53, from the 0.6mm PE sheet. These are the stanchions for the foot ropes. You can now build the spritsail yard, as per plan, as shown here. Again, use a brass pin to attach this to the bowsprit assembly.



468. Paint and fit out all of these assemblies. The lower and middle yards will also need some lengths of 3mm dowel to build the stunsail booms. Here are the mast yards, completed.



469. Here is the completed spritsail yard.

470. Refer to plan sheet 1 & 2 and add the shroud lines making sure they are attached in order, alternating sides.



471. These are now carefully measured and the deadeyes attached. Lanyards are now used to tether these to the deadeyes on the channels, making sure they are taut.

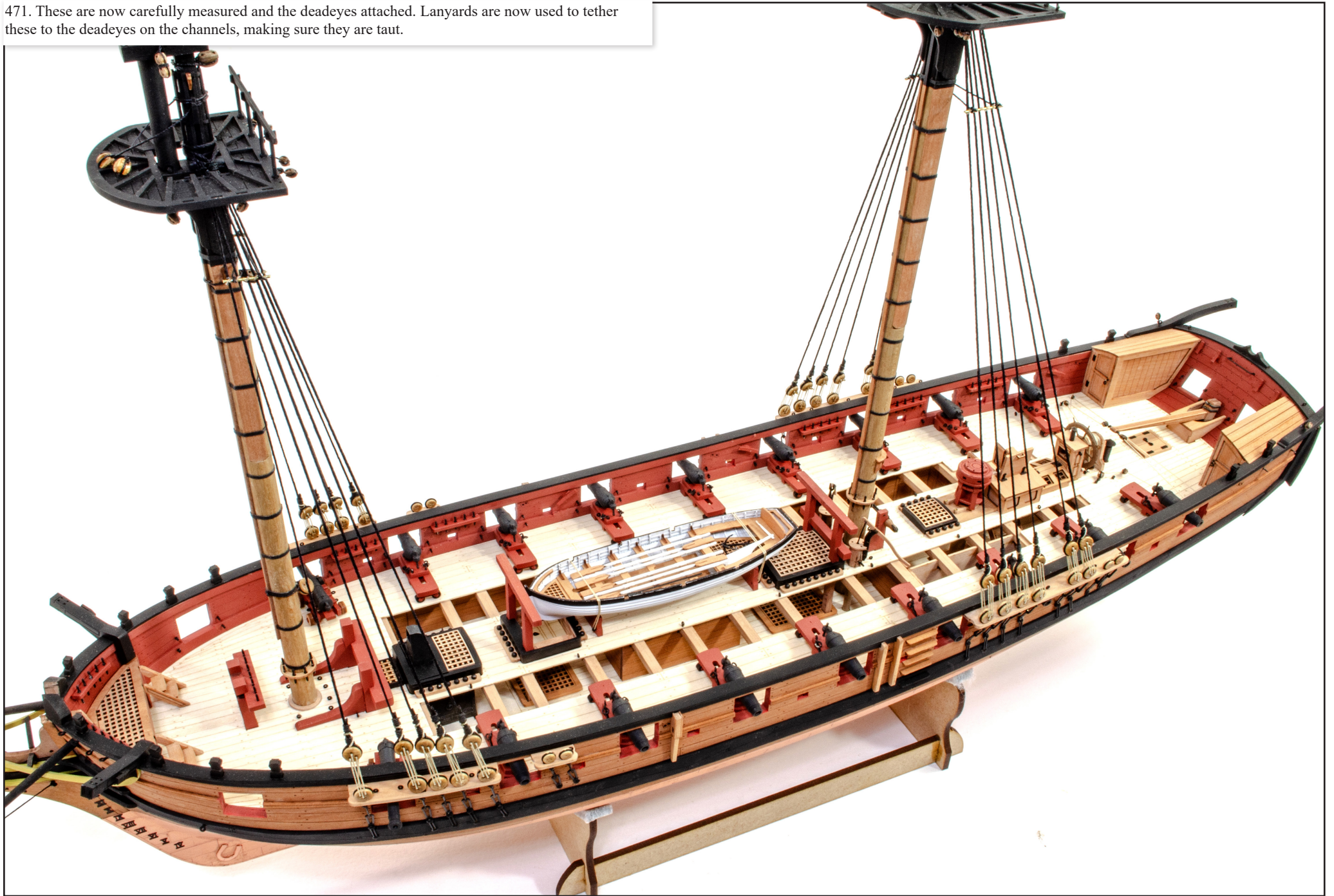

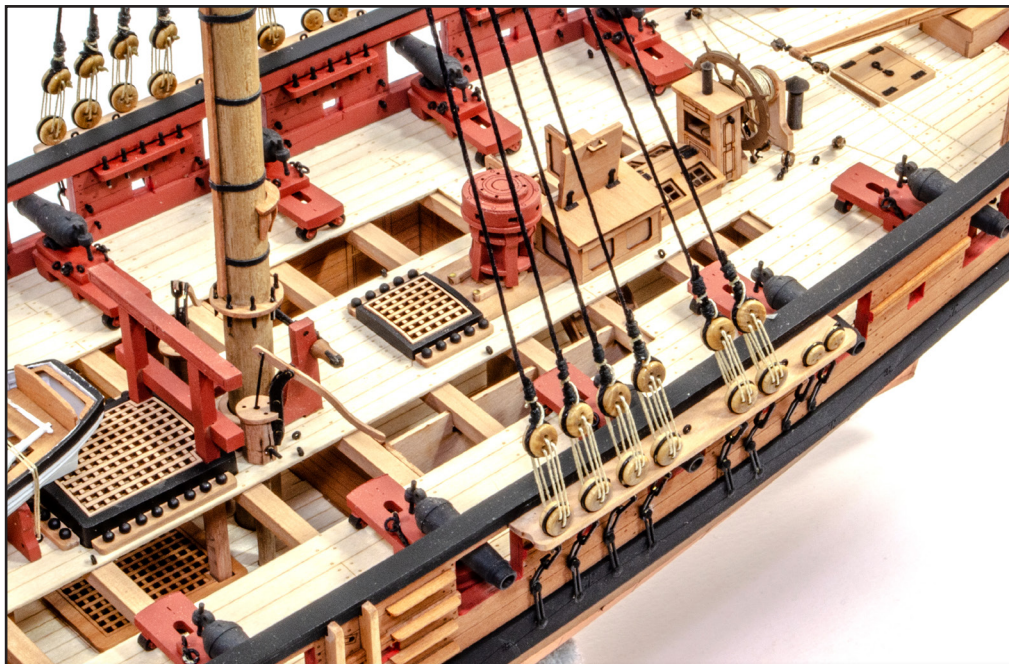

472. Here you can see the main mast shrouds connected via the deadeye arrangement. At this stage, I am not adding the backstays, as these may interfere with the rigging process....although order of rig can be to the modeller's own preference, if they are experienced enough.

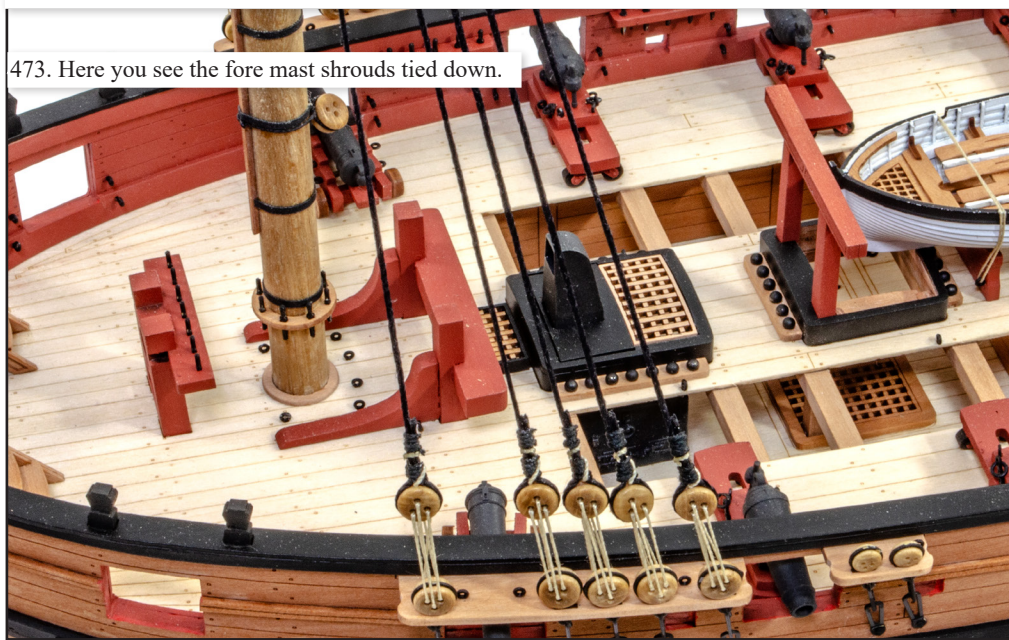

473. Here you see the fore mast shrouds tied down.



474. As per the same plan sheet, you now need to use brass rod and thread to add the catharpins to both main and fore mast shrouds. These provide stability to the shrouds and stop them from being pulled out of shape.

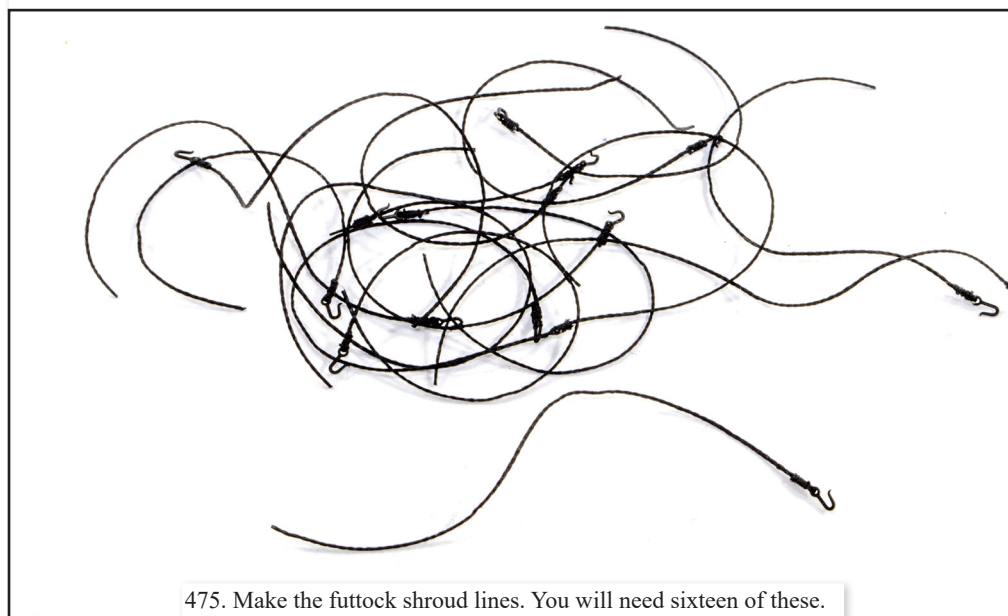

475. Make the futtock shroud lines. You will need sixteen of these.

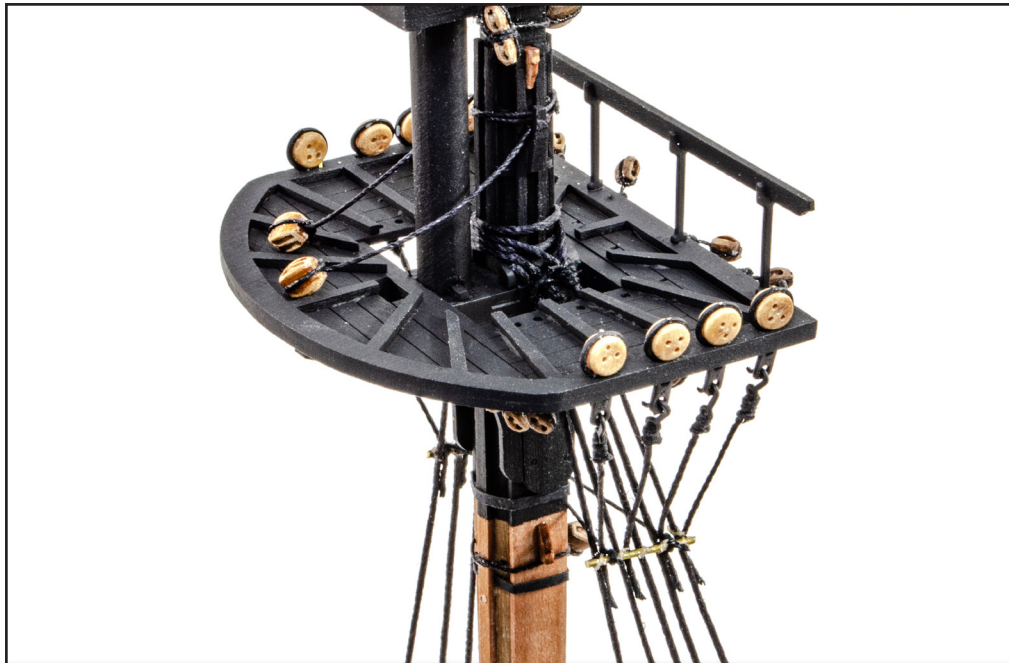

476. Add the 3mm deadeyes to the mast tops and then rig the futtock shrouds into them as shown on the plan.



477. The deadeyes can now be rigged by adding the next set of shroud lines, in the same way as before.

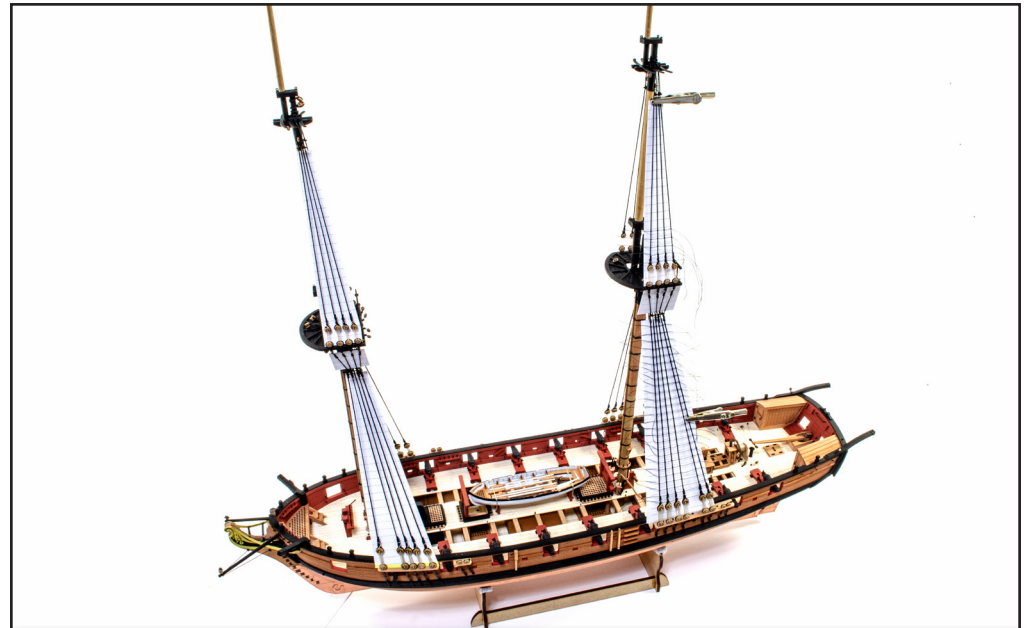

478. I know this is tedious, but it's time to add the ratlines to the shrouds. To aid installation, I use sets of card templates, with lines 6mm apart. Just make sure the lines are horizontal to the waterline.

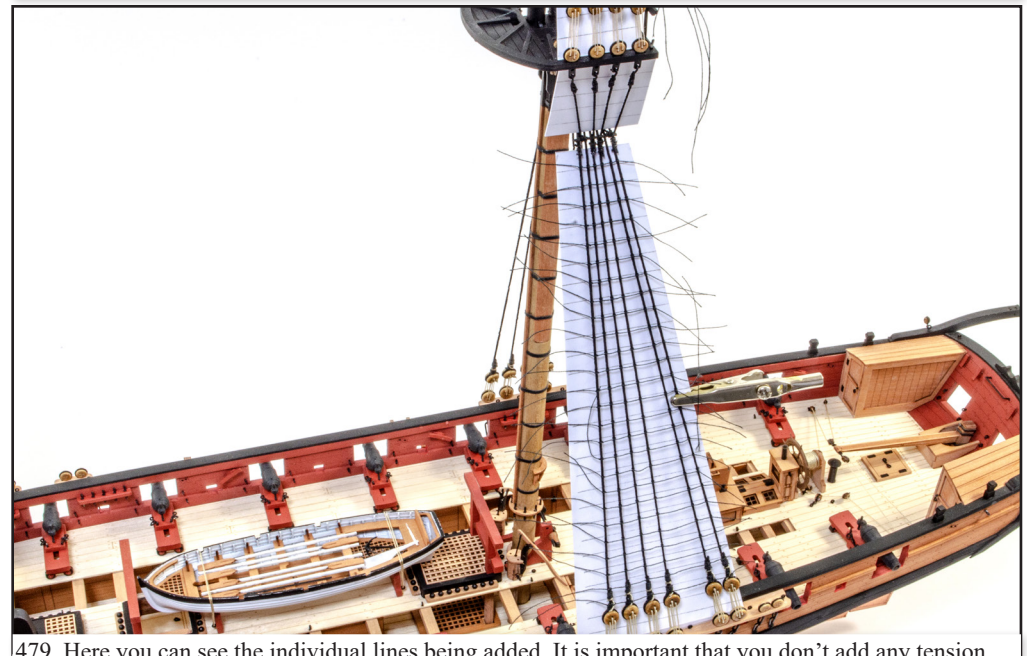

479. Here you can see the individual lines being added. It is important that you don't add any tension into the shroud lines, pulling them out of shape.



480. When complete, brush dilute wood glue into the knots and when dry, snip off the excess at each end of the ratlines.



481. Now add the uppermost shroud lines, and rig as per plan.



482. Now glue the bowsprit into place.

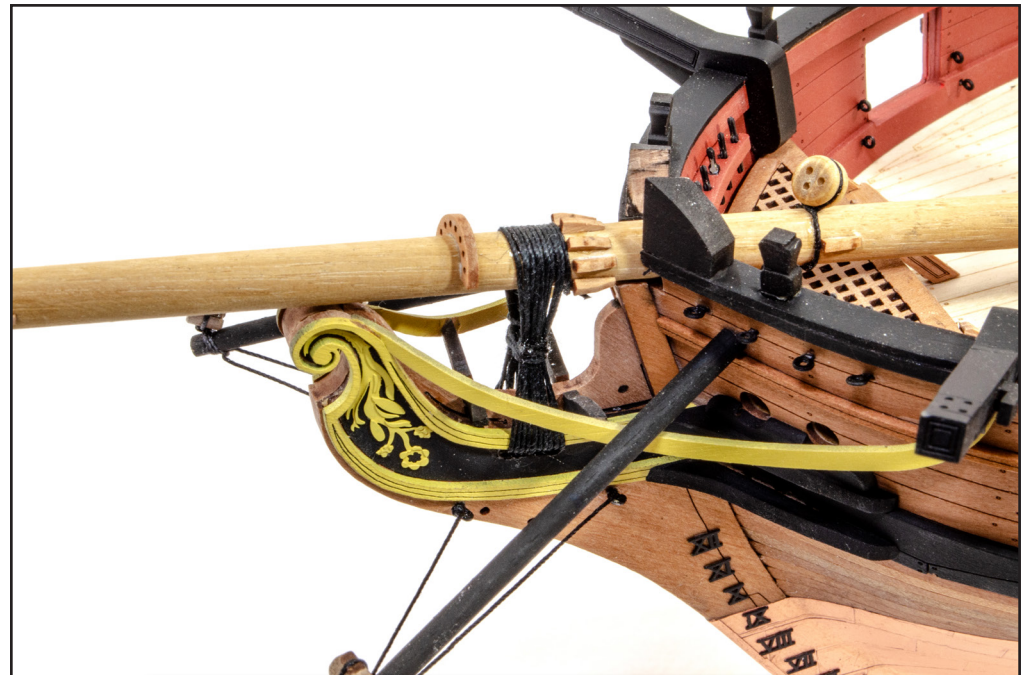

483. Add the gammoning as per plan sheet 1 & 2. Also add the bobstays.

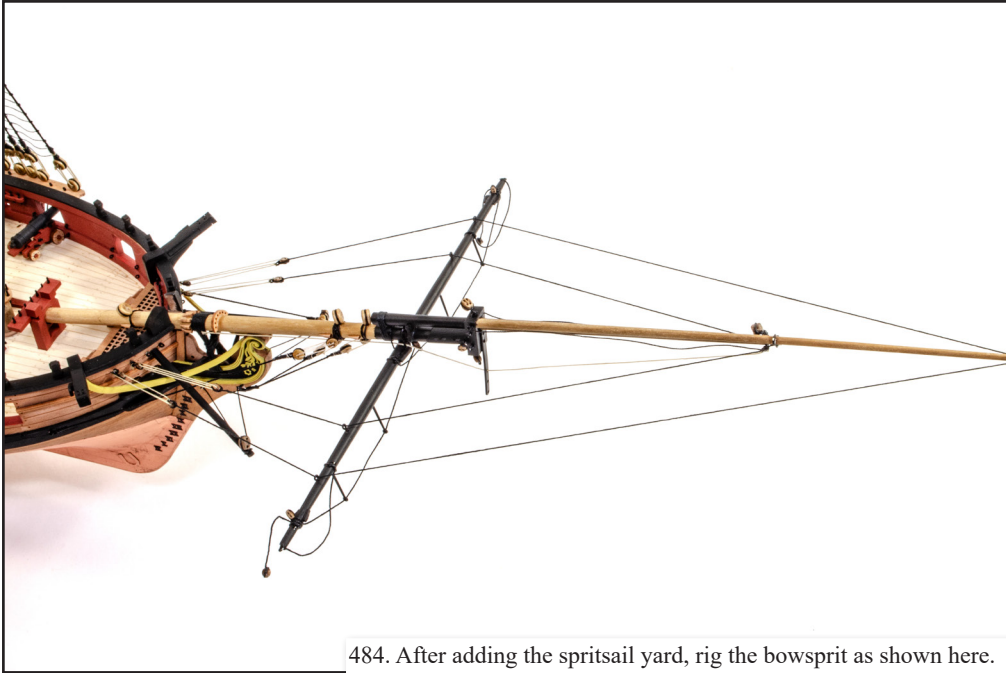

484. After adding the spritsail yard, rig the bowsprit as shown here.

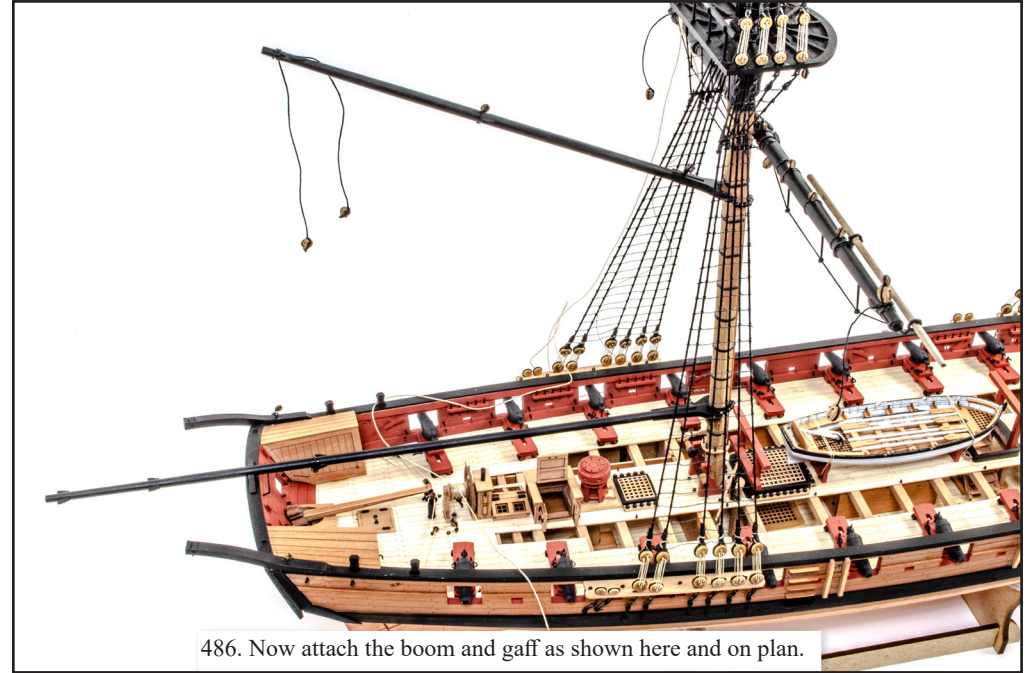

486. Now attach the boom and gaff as shown here and on plan.

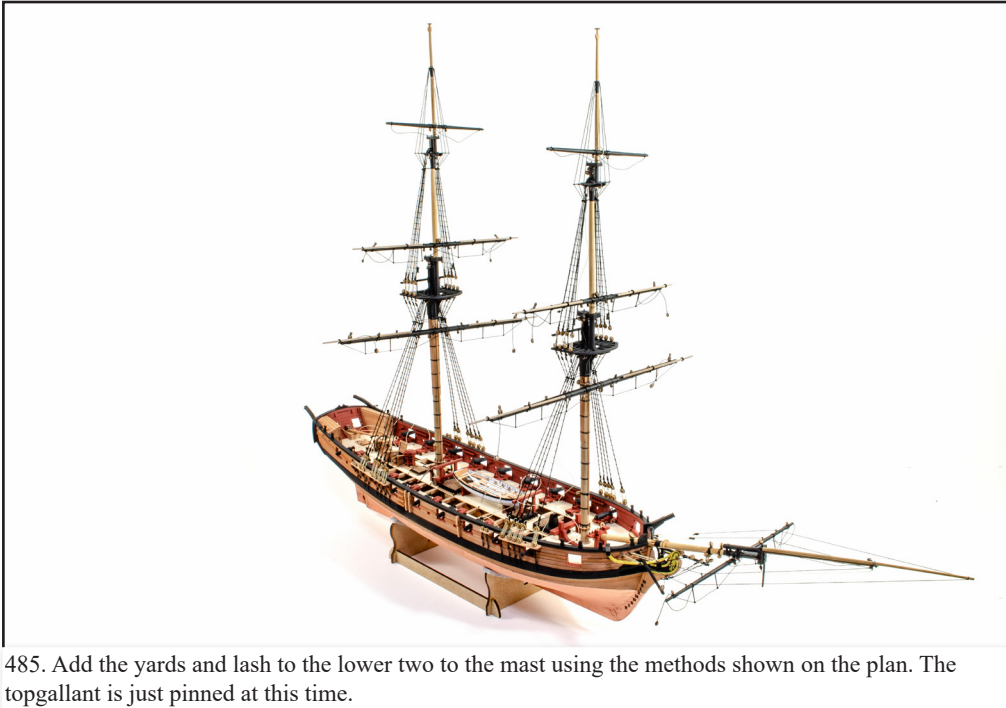

485. Add the yards and lash to the lower two to the mast using the methods shown on the plan. The topgallant is just pinned at this time.

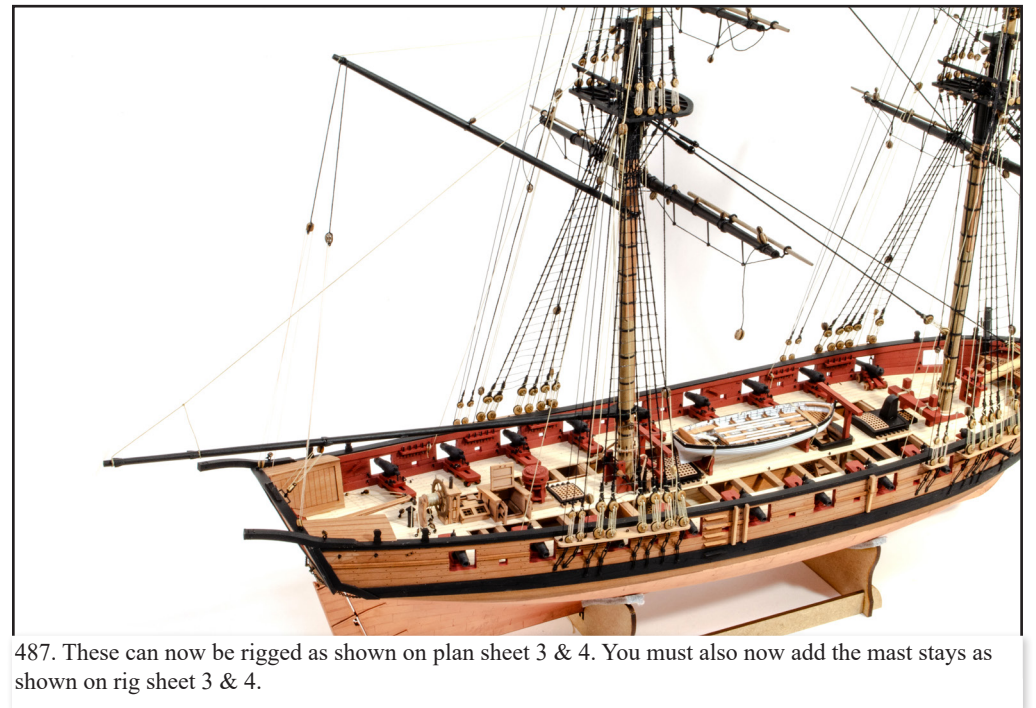

487. These can now be rigged as shown on plan sheet 3 & 4. You must also now add the mast stays as shown on rig sheet 3 & 4.

488. At this stage, the backstays are now attached and rigged.



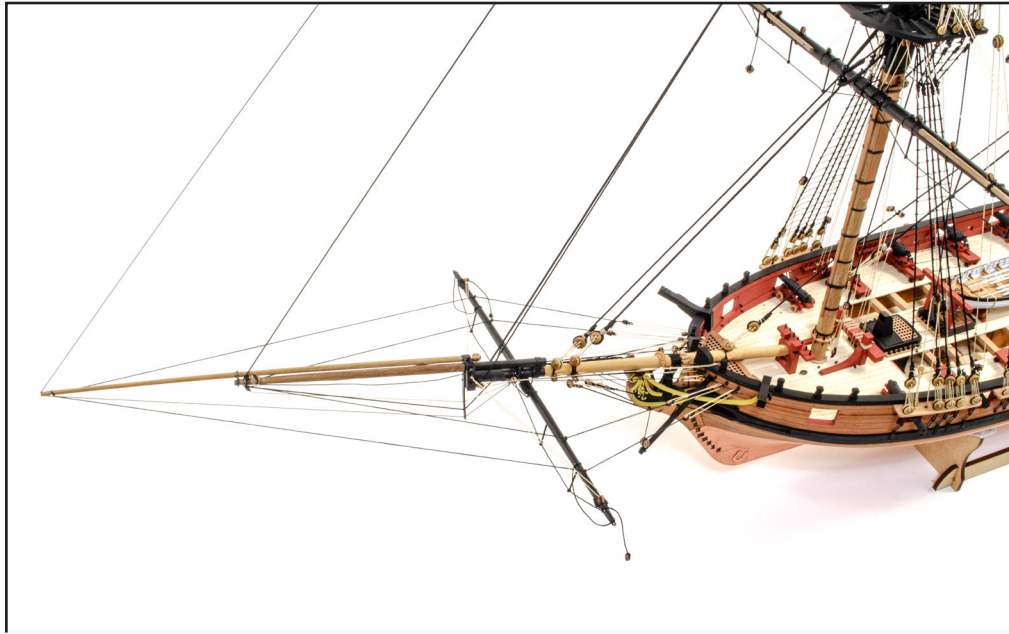

489. Here is a photo showing the stays which have been rigged down to the bowsprit.



490. The yard lifts are now added/rigged.

491. The model can now be rigged as per the plans. For clarity, we have omitted the tacks, bowlines and buntlines. Your kit shows these on the plans and the materials are there to do this if you wish to do a complete, authentic rig. Make up the last two sets of ladders as per the previous ones, and fit them in the locations shown, coinciding with the exterior entry steps.

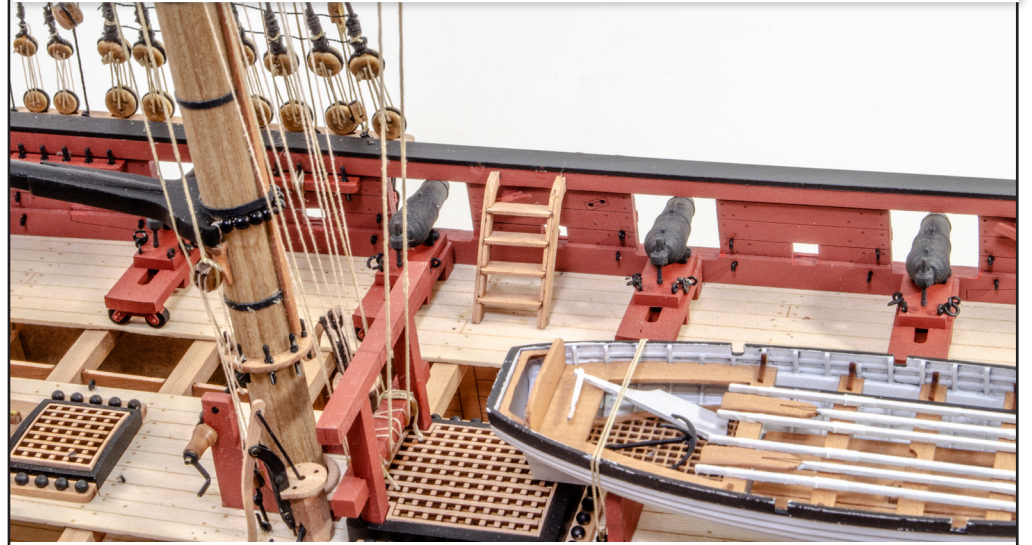

492. Make up the smallest of the two boats and now hang this from the stern of Harpy.



493. From the 0.8mm pear sheet, remove parts AS-2. From the 1.5mm wood sheet, remove parts AS-1. You will also need the anchors.



494. Assemble as shown.



495. Clean up the edges and add the iron straps using the black cartridge paper. Also add the PE rings PE-51 from the 0.6mm PE sheet.



496. Rig the anchors as shown and use the 2mm hawse cable to run from the anchor, through the hawse hole, and down into the holes in the corner of the forward deck grating. Your HMS Harpy is now complete! We hope you enjoyed building this VM kit!

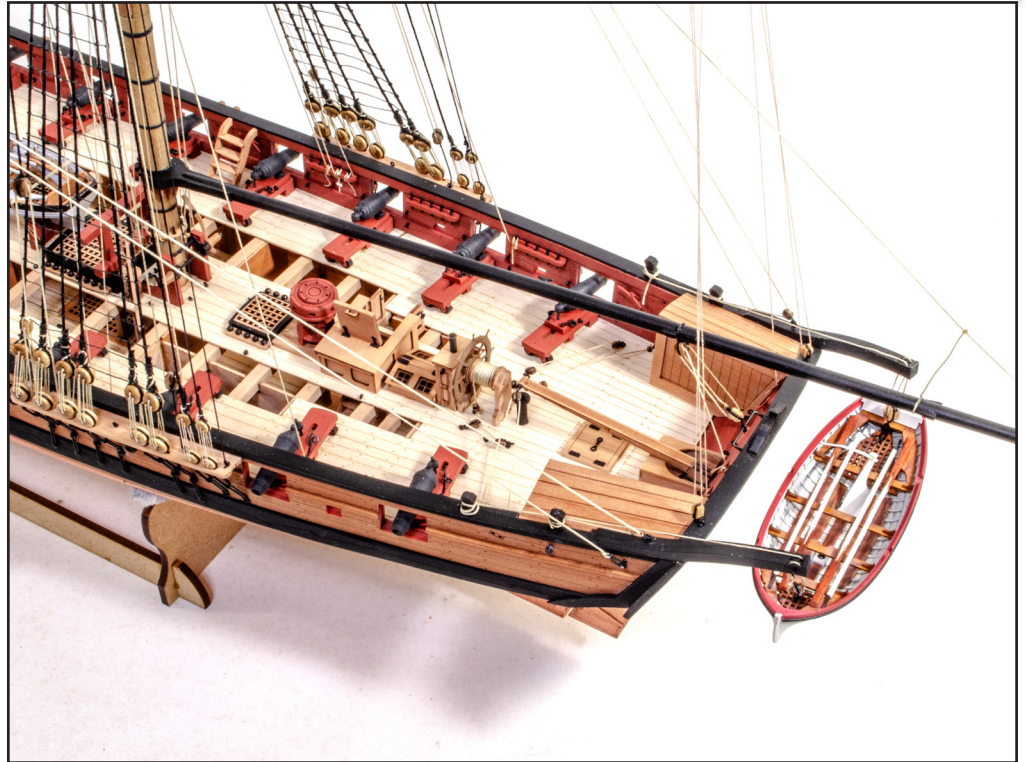







HARPY PARTS LIST

3mm MDF

1	Bulkhead	3mm MDF	1
1A	Bow Planking Pattern (Left Inner)	3mm MDF	1
1B	Bow Planking Pattern (Right Inner)	3mm MDF	1
1C	Bow Planking Pattern (Left Outer)	3mm MDF	1
1D	Bow Planking Pattern (Right Outer)	3mm MDF	1
1E	Bow Planking Pattern (Top)	3mm MDF	2
2	Bulkhead	3mm MDF	1
3	Bulkhead	3mm MDF	1
4	Bulkhead	3mm MDF	1
5	Bulkhead	3mm MDF	1
6	Bulkhead	3mm MDF	1
7	Bulkhead	3mm MDF	1
8	Bulkhead	3mm MDF	1
9	Bulkhead	3mm MDF	2
10	Bulkhead	3mm MDF	1
11	Bulkhead	3mm MDF	1
12	Bulkhead	3mm MDF	1
13	Bulkhead	3mm MDF	1
14	Bulkhead	3mm MDF	1
15	Bulkhead	3mm MDF	1
16	Bulkhead	3mm MDF	1
17	Bulkhead	3mm MDF	1
18	Cradle (Bow)	3mm MDF	1
19	Cradle (Stern)	3mm MDF	1
20	Cradle Support Beam	3mm MDF	2
GPJ-1R	Gun Port Jig (Right Inner)	3mm MDF	9
GPJ-2R	Gun Port Jig (Right Outer)	3mm MDF	9
GPJ-1L	Gun Port Jig (Left Inner)	3mm MDF	9
GPJ-2L	Gun Port Jig (Left Outer)	3mm MDF	9
GPJ-3	Gun Port Jig Handle	3mm MDF	18

2mm MDF

K1	Keel Locking Tab	2mm MDF	8
K2	Lower Deck Locking Tab	2mm MDF	22
21	Inner Keel	2mm MDF	1
22	Keel Doubler Pattern	2mm MDF	2
23	Longitudinal Support	2mm MDF	2
24	Lower Sub Deck	2mm MDF	1
25	Lower Sub Deck Aft	2mm MDF	1
26	Cable Housing Side	2mm MDF	2

27	Stern Frame Pattern	2mm MDF	2
28	Sail Room Side	2mm MDF	2
29	Sail Room Front Pattern	2mm MDF	1
30	Sail Room Rear Pattern	2mm MDF	1
31	Stern Cabin Inner Pattern	2mm MDF	2
32	Stern Cabin Upper Spacer	2mm MDF	2
33	Stern Cabin Lower Spacer	2mm MDF	2
34	Stern Cabin Front Pattern	2mm MDF	2
35	Stern Cabin Rear Pattern	2mm MDF	2
36	Stern Cabin Outer Pattern	2mm MDF	2

0.8mm Plywood

37	Sub Deck	0.8mm Ply	1
38	Stern Counter (Inner)	0.8mm Ply	1
39	Stern Board (Middle)	0.8mm Ply	1
40	Gun Port Pattern (Right)	0.8mm Ply	1
41	Gun Port Pattern (Left)	0.8mm Ply	1

1mm Laser Engraved Limewood

42F	Laser Engraved Sub Deck (Front)	1mm Wood	1
42R	Laser Engraved Sub Deck (Rear)	1mm Wood	1
43	Main Deck	1mm Wood	1

0.6mm Wood

44	Companion Outer Panel (Right)	0.6mm Wood	1
45	Companion Outer Panel (Left)	0.6mm Wood	1
46	Companion Outer Panel (Rear)	0.6mm Wood	1
47	Companion Outer Panel (Front)	0.6mm Wood	1
48	Companion Door (Left)	0.6mm Wood	1
49	Companion Door (Right)	0.6mm Wood	1
50	Companion Door Panel	0.6mm Wood	2
51	Companion Hatch	0.6mm Wood	1
52	Companion Hatch Inner Panel	0.6mm Wood	1
53	Companion Hatch Handle	0.6mm Wood	2
54	Side Outer Panel Strip	0.6mm Wood	2
55	Rear Outer Panel Strip	0.6mm Wood	1
56	Outer Hull Side Step (Upper)	0.6mm Wood	14
57	Outer Hull Side Step (Lower)	0.6mm Wood	14
58	Capstan Ring	0.6mm Wood	2
59	Capstan Ring (Lower)	0.6mm Wood	1
60	Stern Cabin Side Panel (Right)	0.6mm Wood	1

61	Stern Cabin Side Panel (Left)	0.6mm Wood	1
62	Stern Cabin Side Panel (Outer)	0.6mm Wood	1
63	Stern Cabin Front Panel (Right Inner)	0.6mm Wood	1
64	Stern Cabin Front Panel (Right Outer)	0.6mm Wood	1
65	Stern Cabin Front Panel (Left Inner)	0.6mm Wood	1
66	Stern Cabin Front Panel (Left Outer)	0.6mm Wood	1
67	Aft Hatch Step Side (Inner)	0.6mm Wood	2
68	Aft Hatch Step Side (Outer – Left & Right)	0.6mm Wood	2
69	Aft Hatch Step	0.6mm Wood	10
70	Inner Bulwark Side Steps (Inner)	0.6mm Wood	4
71	Inner Bulwark Side Steps (Outer-Sided)	0.6mm Wood	2
72	Inner Bulwark Side Steps (Outer-Sided)	0.6mm Wood	2
73	Inner Bulwark Side Step	0.6mm Wood	10
74	Fore Platform Step Side	0.6mm Wood	4
75	Fore Platform Step Side (Outer-Sided)	0.6mm Wood	2
76	Fore Platform Step Side (Outer-Sided)	0.6mm Wood	2
77	Fore Platform Step	0.6mm Wood	6
78	Fore Hatch Step Side (Inner)	0.6mm Wood	2
79	Fore Hatch Step Side (Outer – Left)	0.6mm Wood	1
80	Fore Hatch Step Side (Outer – Right)	0.6mm Wood	1
81	Fore Hatch Step	0.6mm Wood	8
82	Stern Side Counter Timber (Outer)	0.6mm Wood	2
216A	Chess Tree Side Cheek	0.6mm Wood	4
251L	Tiller Arm Panel (Left)	0.6mm Wood	1
251R	Tiller Arm Panel (Right)	0.6mm Wood	1
C18-1	18 Foot Cutter Stern Sheet	0.6mm Wood	1
C18-2	18 Foot Cutter Stern Floor	0.6mm Wood	1
C18-3	18 Foot Cutter Front Floor	0.6mm Wood	1
C18-4	18 Foot Cutter Thwarts (Bow)	0.6mm Wood	1
C18-5	18 Foot Cutter Stern Platform	0.6mm Wood	1
C18-6	18 Foot Cutter Thwarts (Middle)	0.6mm Wood	1
C18-7	18 Foot Cutter Thwarts (Rear)	0.6mm Wood	1
C18-9	18 Foot Cutter Thwarts Knee	0.6mm Wood	8
C18-10	18 Foot Cutter Rudder	0.6mm Wood	1
C18-11	18 Foot Cutter Rudder Upper Side	0.6mm Wood	2
C18-12	18 Foot Cutter Tiller Arm	0.6mm Wood	1
C18-13	18 Foot Cutter Stern Bulkhead	0.6mm Wood	1
C18-14	18 Foot Cutter Oar	0.6mm Wood	4
M36	Fore Top Batten	0.6mm Wood	8
M37	Main Top Batten	0.6mm Wood	8
M38	Parrel Rib	0.6mm Wood	35

0.8mm Wood

AS2	Anchor Stock (Outer)	0.8mm Wood	8
83	Outer bulwark pattern (Right)	0.8mm Wood	1
84	Outer bulwark pattern (Left)	0.8mm Wood	1
85	Main Wale (Right)	0.8mm Wood	1
86	Main Wale (Left)	0.8mm Wood	1
87	Outer Bulwark Sheer Rail	0.8mm Wood	2
88	Inner Bulwark Sheer Rail	0.8mm Wood	2
89	Inner Bulwark (Right Front)	0.8mm Wood	1
89R	Inner Bulwark (Right Rear)	0.8mm Wood	1
90	Inner Bulwark (Left Front)	0.8mm Wood	1
90R	Inner Bulwark (Left Rear)	0.8mm Wood	1
91	Inner Bulwark Spirketting (Right Front)	0.8mm Wood	1
91a	Inner Bulwark Spirketting (Right Rear)	0.8mm Wood	1
92	Inner Bulwark Spirketting (Left Front)	0.8mm Wood	1
92a	Inner Bulwark Spirketting (Left Rear)	0.8mm Wood	1
93	Main Gunwale	0.8mm Wood	2
94	Main Gunwale (Fore)	0.8mm Wood	2
95	Main Gunwale (Stern)	0.8mm Wood	1
96	Mid Sheer Rail (Front Right)	0.8mm Wood	1
97	Mid Sheer Rail (Right)	0.8mm Wood	1
98	Mid Sheer Rail (Front Left)	0.8mm Wood	1
99	Mid Sheer Rail (Left)	0.8mm Wood	1
100	Stern Side Counter Timber (Inner)	0.8mm Wood	2
101	Fore Platform Support (Inner)	0.8mm Wood	1
102	Fore Platform Support (Outer)	0.8mm Wood	1
103	Fore Platform Support Frame	0.8mm Wood	1
103a	Fore Platform	0.8mm Wood	1
104	Prow hair Bracket (Right)	0.8mm Wood	1
105	Prow hair Bracket (Left)	0.8mm Wood	1
106	Lower Stern Planking (Left)	0.8mm Wood	1
107	Lower Stern Planking (Right)	0.8mm Wood	1
108	Stern Counter (Inner)	0.8mm Wood	1
109	Stern Board (Inner)	0.8mm Wood	1
110	Stern Counter (Outer)	0.8mm Wood	1
111	Stern Counter Rail (Left)	0.8mm Wood	1
112	Stern Counter Rail (Right)	0.8mm Wood	1
113	Stern Board (Outer)	0.8mm Wood	1
114	Stern Board Surround	0.8mm Wood	1
115	Stern Cabin Canopy (Pantry - Right)	0.8mm Wood	1
116	Stern Cabin Canopy (Toilet - Left)	0.8mm Wood	1
117	Hand Pump Handle	0.8mm Wood	2
118	Capstan Whelp Spacer	0.8mm Wood	1

119	Capstan Drum Top	0.8mm Wood	1	131	Main Mast Base	1mm Wood	2
120	Capstan Drum Top Cap	0.8mm Wood	1	132	Ships Wheel End Drum	1mm Wood	2
M13	Main Boom Saddle	0.8mm Wood	1	133	Cathead Sheave Pattern	1mm Wood	4
M14	Main Boom Saddle Support Knee	0.8mm Wood	1	134	Cathead End cap	1mm Wood	2
M15R	Fore Bib (Right)	0.8mm Wood	1	135	Left prow Pattern	1mm Wood	1
M15L	Fore Bib (Left)	0.8mm Wood	1	136	Right prow Pattern	1mm Wood	1
M16R	Main Bib (Right)	0.8mm Wood	1	136b	Bulwark Bolster for Prow	1mm Wood	2
M16L	Main Bib (Left)	0.8mm Wood	1	137	Right Keel Pattern	1mm Wood	1
M17	Fore Mast Cheek	0.8mm Wood	2	138	Left Keel Pattern	1mm Wood	1
M18	Fore Mast 'Rubbing Paunch'	0.8mm Wood	1	139	Rudder Post Pattern	1mm Wood	2
M19	Main Mast Cheek	0.8mm Wood	2	140	Prow Pattern Bolster	1mm Wood	2
M20	Main Mast 'Rubbing Paunch'	0.8mm Wood	1	141	Rudder Side Pattern (Right)	1mm Wood	1
C22-1	22 Foot Cutter Centre Floor	0.8mm Wood	1	142	Rudder Side Pattern (Left)	1mm Wood	1
C22-2	22 Foot Cutter Centre Floor (Middle Outer)	0.8mm Wood	2	143	Capstan Chock	1mm Wood	2
C22-3	22 Foot Cutter Centre Floor (Outer)	0.8mm Wood	2	144	Rudder Housing Side Panel	1mm Wood	2
C22-4	22 Foot Cutter Aft Grating	0.8mm Wood	1	145	Rudder Housing End Panel	1mm Wood	1
C22-5	22 Foot Cutter Fore Grating	0.8mm Wood	1	146	Rudder Housing Top	1mm Wood	1
C22-6	22 Foot Cutter Thwart (Fore)	0.8mm Wood	1	147	Head Rail	1mm Wood	2
C22-7	22 Foot Cutter Thwart	0.8mm Wood	1	148	Aft Small Hatch Combing	1mm Wood	1
C22-8	22 Foot Cutter Thwart	0.8mm Wood	1	149	Aft Small Hatch Grating	1mm Wood	1
C22-9	22 Foot Cutter Thwart	0.8mm Wood	1	150	Main Hatch Combing	1mm Wood	1
				151	Main Hatch Grating	1mm Wood	1
C22-11	22 Foot Cutter Stern Sheets	0.8mm Wood	1	152	Fore Ladderway Hatch Combing	1mm Wood	1
C22-12	22 Foot Cutter Stern Knee	0.8mm Wood	1	153	Fore Hatch and Chimney Combing	1mm Wood	1
C22-13	22 Foot Cutter Stern Sheets	0.8mm Wood	1	154	Fore Hatch Grating	1mm Wood	1
C22-14	22 Foot Cutter Bow Knee	0.8mm Wood	1	155	Chimney Cover	1mm Wood	1
C22-15	22 Foot Cutter Main Mast Base	0.8mm Wood	1	156	Small Fore Hatch Grating	1mm Wood	1
C22-16	22 Foot Cutter Fore Mast Base	0.8mm Wood	1	157	Gallows Cross Beam Outer Pattern	1mm Wood	4
C22-17	22 Foot Cutter Rudder	0.8mm Wood	1	158	Gallows Cross Beam (Fore)	1mm Wood	1
C22-18	22 Foot Cutter Thwart Knee	0.8mm Wood	14	159	Gallows Cross Beam (Aft)	1mm Wood	1
C22-19	22 Foot Cutter Oar	0.8mm Wood	6	160	Stern Davit Sheave Block	1mm Wood	4
				161	Stern Davit End Cap	1mm Wood	4
				162	Hand Pump Top Cap	1mm Wood	2
				163	Binnacle Side Panel	1mm Wood	2
				164	Binnacle Cross Piece (Top)	1mm Wood	1
				165	Binnacle Cross Piece (Middle)	1mm Wood	1
				166	Binnacle Cross Piece (Lower)	1mm Wood	1
				167	Binnacle Top	1mm Wood	1
				168	Binnacle Front Panel	1mm Wood	1
				169	Binnacle Rear Panel	1mm Wood	1
				170	Cable Room Left Panel	1mm Wood	1
				171	Cable Room Right Panel	1mm Wood	1
				172	Mid-Deck Cabin Cross-Bulkhead	1mm Wood	1
				173	Fore Cabin Longitudinal Bulkhead (Right)	1mm Wood	1

1mm Wood

121	Companion Hatch Front Bulkhead (Inner)	1mm Wood	1
122	Companion Hatch Side (Inner)	1mm Wood	2
123	Companion Hatch Rear (Inner)	1mm Wood	1
124	Companion Roof	1mm Wood	1
125	Skylight End Pattern	1mm Wood	2
126	Skylight Side Pattern	1mm Wood	2
127	Skylight Hatch Cross beam (Lower)	1mm Wood	1
128	Skylight Hatch Cross beam (Upper)	1mm Wood	1
129	Skylight Hatch	1mm Wood	2
130	Fore Mast Base	1mm Wood	1

174	Fore Cabin Longitudinal Bulkhead (Left)	1mm Wood	1
175	Fore Cabin Cross-Bulkhead (Right)	1mm Wood	1
176	Fore Cabin Cross-Bulkhead (Left)	1mm Wood	1
177	Fore Cabin Foremost Cross-Bulkhead	1mm Wood	1
178	Aft Cabin Rearmost Bulkhead	1mm Wood	1
179	Aft Cabins Longitudinal Bulkhead (Left)	1mm Wood	1
180	Aft Cabins Longitudinal Bulkhead (Left)	1mm Wood	1
181	Aft Cabins Longitudinal Bulkhead (Right)	1mm Wood	1
182	Sail Room Side Panel (Right)	1mm Wood	1
183	Sail Room Side Panel (Left)	1mm Wood	1
184			
185	Aft Cabin Longitudinal Bulkhead (Right)	1mm Wood	1
186	Aft Cabin Longitudinal Bulkhead (Left)	1mm Wood	1
187	Aft Cabin Longitudinal Bulkhead (Left)	1mm Wood	1
188	Sail Room Front Panel	1mm Wood	1
189	Sail Room Rear Panel	1mm Wood	1
K3	Keel, Prow and Rudder Post Locking Key	1mm Wood	8
PE-46	Alternative Material Dolphin Striker (1796)	1mm Wood	1
PE-46	Alternative Dolphin Striker (Post 1800)	1mm Wood	1
M1	Mast and Yard Cleat	1mm Wood	80
M2	Mast and Yard Cleat (Small)	1mm Wood	36
M3	Fore Top Lower Platform	1mm Wood	1
M4	Fore Top Gunwale and Battens	1mm Wood	1
M5	Fore Top Rear Rail	1mm Wood	1
M6	Main Top Lower Platform	1mm Wood	1
M7	Main Top Gunwale and Battens	1mm Wood	1
M8	Main Top Rear Rail	1mm Wood	1
M9	Fore and Main Mast Belaying Ring	1mm Wood	2
M10	Fore and Main Topgallant Mast cap	1mm Wood	2
M11	Bowsprit Bee	1mm Wood	1
M12	Jib Boom Saddle	1mm Wood	1
M36	Bowsprit fairlead Saddle	1mm Wood	1
M37F	Topmast and Topgallant Mast Fid	1mm Wood	4

1.5mm Wood

190	Main Mast, Deck Pump and Bitts Base	1.5mm Wood	1
191	Shot Garland (Main Hatch Front)	1.5mm Wood	1
192	Shot Garland (Aft Hatch Left and Right)	1.5mm Wood	2
193	Shot Garland (Fore Hatch Left and Right)	1.5mm Wood	2
194	Shot Garland (Fore Ladderway Fore and Aft)	1.5mm Wood	2
195	Shot Garland (Main Hatch Left and Right)	1.5mm Wood	2
196	Capstan Support Chock	1.5mm Wood	1
197	Capstan Support Base	1.5mm Wood	1

198	Capstan Bar Ring	1.5mm Wood	1
199	Foremost Hatch Coaming	1.5mm Wood	1
200	Bread Hatch (Aft)	1.5mm Wood	1
201	Main Hatch (Lower Deck)	1.5mm Wood	1
202	Fore Hatch (Lower Deck)	1.5mm Wood	1
203	Prow 'V' Rail (Aft)	1.5mm Wood	1
204	Prow 'V' Rail (Fore)	1.5mm Wood	1
205	Main Hatch Camber Pattern	1.5mm Wood	1
206	Main Hatch Camber Pattern	1.5mm Wood	1
207	Aft Hatch Coaming and Capstan Floor	1.5mm Wood	1
207a	Aft Hatch Upper Coaming	1.5mm Wood	1
208	Ships Wheel Standard	1.5mm Wood	2
209	Hawse Bolster	1.5mm Wood	2
210	Fore Channel	1.5mm Wood	2
211	Fore Channel Stool	1.5mm Wood	2
212	Main Channel	1.5mm Wood	2
213	Inner Bulwark Belaying Rack	1.5mm Wood	10
214	Inner Bulwark Belaying Rack (Foremost)	1.5mm Wood	2
215	Hull Side Fender	1.5mm Wood	4
216	Chess Tree	1.5mm Wood	2
217			
218	Inner Bulwark Large Cleat	1.5mm Wood	8
219	Inner Bulwark Small Cleat	1.5mm Wood	8
220	Chimney Hatch Camber Pattern	1.5mm Wood	1
221	Chimney Hatch Camber Pattern	1.5mm Wood	1
222	Capstan Pawl	1.5mm Wood	2
223	6-Pounder Cannon Carriage Side (Right)	1.5mm Wood	2
224	6-Pounder Cannon Carriage Side (Left)	1.5mm Wood	2
225	6-Pounder Cannon Carriage Front Axle	1.5mm Wood	2
226	6-Pounder Cannon Carriage Rear Axle	1.5mm Wood	2
227	6-Pounder Cannon Carriage Quoin	1.5mm Wood	2
228	6-Pounder Cannon Carriage Front Wheel	1.5mm Wood	4
229	6-Pounder Cannon Carriage Rear Wheel	1.5mm Wood	4
M21	Fore Topmast Trestle Tree	1.5mm Wood	2
M22	Main Topmast Trestle Tree	1.5mm Wood	2
M23	Mast/Yard Sling Cleat	1.5mm Wood	21
M37	Shroud Cleat	1.5mm Wood	8
AS-1	Anchor Stock (Inner)	1.5mm Wood	8

2mm Wood

230	32-Pounder Carronade Slide Bed	2mm Wood	16
231	32-Pounder Carronade Carriage	2mm Wood	16
232	32-Pounder Carronade Slide Bed Cross Beam	2mm Wood	16

233	32-Pounder Carronade Slide Pin	2mm Wood	16	268	Deck Pump Body	3mm Wood	6
235	Bow Upper and Lower Cheek	2mm Wood	4	269	Fore Hatch Camber Beam	3mm Wood	1
236	Prow	2mm Wood	1	270	Main Hatch Camber Beam	3mm Wood	2
237	Keel	2mm Wood	1	M30	Lower Trestle Tree Spacer (Fore and Main)	3mm Wood	2
238	Rudder Post	2mm Wood	1	M31	Main Boom Jaws	3mm Wood	1
239	Rudder	2mm Wood	1	M32	Main Gaff Jaws	3mm Wood	1
240	Prow Knee	2mm Wood	1	M33	Top Mast Cap (Fore and Main)	3mm Wood	2
241	Gunwale Timberhead	2mm Wood	14	B-16	Upper Deck Beam	3mm Wood	2
242	Cathead Knee	2mm Wood	2				
243	Fore Hatch Camber Beam	2mm Wood	2			4mm Wood	
244	Rear Hatch Camber Beam	2mm Wood	4				
245	Bowsprit Bitts Belaying Rack	2mm Wood	1	234	Stern Davit	4mm Wood	2
246	Upper Deck Ledge	2mm Wood	2	272	Bowsprit Bitts	4mm Wood	1
247	Upper Deck Ledge	2mm Wood	2	273	Fore Bitts	4mm Wood	2
248	Upper Deck Ledge	2mm Wood	2	274	Fore Bitts Cross Beam	4mm Wood	1
249	Upper Deck Ledge	2mm Wood	2	275	Fore Gunwale Bow Timber	4mm Wood	2
250	Upper Deck Ledge	2mm Wood	2	276	Main Hatch Lower Coaming	4mm Wood	1
251	Tiller Arm	2mm Wood	1	277	Fore Ladderway Lower Coaming	4mm Wood	1
252	Capstan Whelp	2mm Wood	6	278	Fore Hatch Lower Coaming	4mm Wood	1
253	Aft Main Mast Bitts (Left)	2mm Wood	1	B-1	Upper Deck Beam	4mm Wood	1
254	Aft Main Mast Bitts (Right)	2mm Wood	1	B-2	Upper Deck Beam	4mm Wood	1
255	Main Boom Cradle	2mm Wood	1	B-3	Upper Deck Beam	4mm Wood	1
256	Cathead (Right)	2mm Wood	1	B-4	Upper Deck Beam	4mm Wood	1
257	Cathead (Right)	2mm Wood	1	B-5	Upper Deck Beam	4mm Wood	1
258	Cathead (Left)	2mm Wood	1	B-6	Upper Deck Beam	4mm Wood	1
259	Cathead (Left)	2mm Wood	1	B-7	Upper Deck Beam	4mm Wood	1
260	Cathead Cleat	2mm Wood	2	B-8	Upper Deck Beam	4mm Wood	1
261	18 Foot Cutter Cradle (Front – Optional)	2mm Wood	1	B-9	Upper Deck Beam	4mm Wood	1
262	18 Foot Cutter Cradle (Rear – Optional)	2mm Wood	1	B-10	Upper Deck Beam	4mm Wood	1
M24	Fore Trestle Tree	2mm Wood	2	B-11	Upper Deck Beam	4mm Wood	1
M25	Fore Cross Tree	2mm Wood	2	B-12	Upper Deck Beam	4mm Wood	1
M26	Topmast Bolster	2mm Wood	4	B-13	Upper Deck Beam	4mm Wood	1
M27	Main Cross Tree	2mm Wood	2	B-14	Upper Deck Beam	4mm Wood	1
M28	Main Trestle Tree	2mm Wood	2	B-15	Upper Deck Beam	4mm Wood	1
M29	Lower Top Bolster	2mm Wood	4	B-17	Upper Deck Beam	4mm Wood	1
				M34	Lower Mast Cap (Fore and Main)	4mm Wood	2
				M35	Bowsprit Cap	4mm Wood	1
		3mm Wood					
230a	32-Pounder Carronade Slide Bed Front Chock	3mm Wood	18			2mm Clear Acetate	
263	Fore Gallows Bitts	3mm Wood	2	279	Display Stand Fore Cradle	2mm Acetate	1
264	Main Gallows Bitts	3mm Wood	2	280	Display Stand Rear Cradle	2mm Acetate	1
265	Main Gallows Bitts Cross Beam	3mm Wood	1	281	Display Stand Cross Support	2mm Acetate	2
266	Fore Bitts Knee	3mm Wood	2	282	Display Stand Nameplate Cross Support	2mm Acetate	2
267	Ships Wheel Centre Drum	3mm Wood	2				

283	Display Stand Nameplate	2mm Acetate	2
-----	-------------------------	-------------	---

0.2mm Black Card

R1-R4	Right Rudder Gudgeon	0.2mm Black Card	1
R5-R8	Right Rudder Pintle	0.2mm Black Card	1
L1-L4	Left Rudder Gudgeon	0.2mm Black Card	1
L5-L8	Left Rudder Pintle	0.2mm Black Card	1
R9	Rudder Head Strap	0.2mm Black Card	5
As3	Anchor Stock Strap	0.2mm Black Card	16

0.2mm Photo-Etched Brass

PE-1	Prow Horseshoe Plate	0.2mm PE	2
PE-2	Stern Fish Plate	0.2mm PE	2
PE-3	Compass Dial	0.2mm PE	2
PE-4	Ships Wheel Outer Plate	0.2mm PE	2
PE-5	Ships Wheel Centre Plate	0.2mm PE	2
PE-6	Door Hinge	0.2mm PE	16
PE-7	Companion Door/Hatch Hinge	0.2mm PE	8
PE-8	Door Hinge (Stern cabins and Lower Cabins)	0.2mm PE	30
PE-9	Depth Markings	0.2mm PE	2
PE-10	Prow Scroll Work (Left)	0.2mm PE	1
PE-11	Prow Scroll Work (Right)	0.2mm PE	1
PE-12	Lower yard Stunsail Strap	0.2mm PE	4
PE-13	Upper yard Stunsail Strap	0.2mm PE	4

0.4mm Photo-Etched Brass

PE-14	Main Eyebolt	0.4mm PE	460
PE-15	Outer Hull Eyebolt	0.4mm PE	38
PE-16	32-Pounder Carronade Eye Ring Strap	0.4mm PE	36
PE-17	32-Pounder Carronade Ring	0.4mm PE	36
PE-18	5mm Deadeye Chainplate	0.4mm PE	24
PE-19	5mm Deadeye Chainplate Upper Link	0.4mm PE	30
PE-20	5mm Deadeye Chainplate Middle Link	0.4mm PE	24
PE-21	5mm Deadeye Chainplate Lower Link	0.4mm PE	24
PE-22	3mm Deadeye Chainplate	0.4mm PE	12
PE-23	3mm Deadeye Chainplate Upper Link	0.4mm PE	12
PE-24	3mm Deadeye Chainplate Lower Link	0.4mm PE	12
PE-25	3mm Futtock Strop	0.4mm PE	19
PE-26	3mm Futtock Strop Hook	0.4mm PE	20
PE-27	Hand Pump Forked Stanchion Outer Pattern	0.4mm PE	4
PE-28	Hand Pump Forked Stanchion Inner Pattern	0.4mm PE	4

PE-29	Hand Pump Operating Rod	0.4mm PE	2
PE-30	Main Bitts Winch Drum Gear	0.4mm PE	2
PE-31	Main Bitts Winch Drum Gear Pawl	0.4mm PE	2
PE-32	Rigging Hook	0.4mm PE	30
PE-33	Skylight Window frame	0.4mm PE	4
PE-34	Kedge Anchor Main Body	0.4mm PE	2
PE-35	Kedge Anchor Cross Piece	0.4mm PE	2
PE-36	Grab Hook	0.4mm PE	2
PE-37	Flying Jibboom Ring	0.4mm PE	2
PE-38	Flying Jibboom Iron	0.4mm PE	2
PE-39	Main Sheet Bar	0.4mm PE	1

0.6mm Photo-Etched Brass

PE-40	Lower Stunsail Boom Iron (Inner)	0.6mm PE	4
PE-41	Upper Stunsail Boom Iron (Inner)	0.6mm PE	4
PE-42	Lower Stunsail Boom Iron (Outer)	0.6mm PE	4
PE-43	Upper Stunsail Boom Iron (Outer)	0.6mm PE	4
PE-44	Main Topmast Cross Tree & Trestle Tree	0.6mm PE	1
PE-45	Fore Topmast Cross Tree & Trestle Tree	0.6mm PE	1
PE-46	Dolphin Striker	0.6mm PE	1
PE-47	6-Pounder Carriage Cross Iron	0.6mm PE	4
PE-48	Main Bitts Winch Drum Handle	0.6mm PE	2
PE-49	Rudder Spectacle Plate	0.6mm PE	1
PE-50	Ships Wheel Main Body	0.6mm PE	1
PE-51	Anchor Ring	0.6mm PE	4
PE-52	Lower Tops Stanchion	0.6mm PE	10
PE-53	Yard Footrope Stirrup	0.6mm PE	25
PE-54	Belaying Pin	0.6mm PE	108
PE-55	Small Iron Cleat	0.6mm PE	12

Fittings

F-1	32 Pounder Carronade Barrel	3-D Print	16
F-2	32 Pounder Carronade Wheels	3-D Print	16
F-3	6-Pounder Cannon (Long)	3-D Print	2
F-4	Winch Drum	3-D Print	2
F-5	Anchor	3-D Print	4
F-6	Binnacle Chimney	3-D Print	1
F-7	Aft Chimney	3-D Print	1
F-8	Stove	3-D Print	1
F-9	Stove Chimney	3-D Print	1
F-10	18 Foot Cutter Hull	3-D Print	1
F-11	2mm Diameter Black Cannon Ball	Acrylic or Steel	60
F-12	Small pin	Brass	300
F-13	Rudder Chain – 150mm Approx.	Metal	1
F-14	3.5mm Diameter Sheave	4280/35	10
F-15	5mm Deadeye	4050/05	64
F-16	3mm Deadeye	4050/03	60
F-17	3mm Single block	4070/03	140
F-18	5mm Single block	4070/05	40
F-19	4mm Double block	4080/04	30
F-20	7mm Sister block	4083/05	6
F-21	Parrel bead	Plastic	70
F-22	Large mouse bead (Lower mast stays)	Plastic	6
F-23	Small mouse bead (Upper mast stays)	Plastic	6

Materials

F-24	0.1mm Diameter natural thread		100m
F-25	0.25mm Diameter natural thread		40m
F-26	0.5mm Diameter natural thread		20m
F-27	0.75mm Diameter natural thread		10m
F-28	0.25mm Diameter black thread		20m
F-29	0.5mm Diameter black thread		20m
F-30	0.75mm Diameter black thread		20m
F-31	1mm Diameter black thread		20m
F-32	1.5mm Diameter black thread		20m
F-33	2mm Diameter natural thread (Anchor hawse)		0.5m
F-34	8mm Dowel x 500mm long	Wood	2
F-35	6mm Dowel x 500mm long	Wood	5
F-36	5mm Dowel x 500mm long	Wood	4
F-37	4mm Dowel x 500mm long	Wood	5
F-38	3mm Dowel x 500mm long	Wood	4
F-39	2mm Dowel x 500mm long	Wood	2

F-40	1 x 5 x 500mm long Limewood	Wood	40
F-41	0.8 x 4 x 500mm long Second planking	Wood	46
F-42	0.8mm Diameter brass rod x200mm long (Approx.)	Metal	1
F-43	0.5mm Diameter brass rod x 200mm long (Approx.)	Metal	1
F-44	Copper Tape Roll for Coppering Bottom	Copper	1
F-45	Black Card for Mast Rings	Card	1
F-46	22 Foot Cutter Hull	Resin	1

Harpy Laser and PE Sheet Quantities

3mm MDF Laser Cut	2
2mm MDF Laser cut	2
2mm Clear Acetate	1
0.6mm Pear Wood x 500mm Long	1
0.8mm Pear Wood x 600mm Long	3
0.8mm Pear Wood x 500mm Long	2
1mm Pear Wood x 500mm long	3
1.5mm Pear Wood x 250mm long	1
1.5mm Pear Wood x 72mm long	1
2mm Pear Wood x 500mm long	1
3mm Pear Wood x 160mm Long	1
4mm Pear Wood x 250mm Long	1
0.8mm Plywood	1
1mm Wood laser etched deck	2
0.2mm Laser Cut Black Card	1
0.2mm Photo Etched Brass Sheet	1
0.4mm Photo Etched Brass Sheet	1
0.6mm Photo Etched Brass Sheet	1

VANGUARD MODELS

BY CHRIS WATTON

©Vanguard Models is a subsidiary of Burncroft Limited

Registered Office:

70B, High Street

Cinderford

Gloucestershire

GL14 2SZ

UK

Tel (0044) [0]1594 824610

Registered company number – 04317996

Website - www.vanguardmodels.co.uk

Email - sales@vanguardmodels.com

HARPY was designed and developed in the UK by Chris Watton

Finished prototype model made and photographed (including construction manual text) by James Hatch

17/11/2024