

The 20 Gun Sixth Rate

HMS Sphinx 1775

Building Manual

Revision 1

PART NUMBER - VM-07

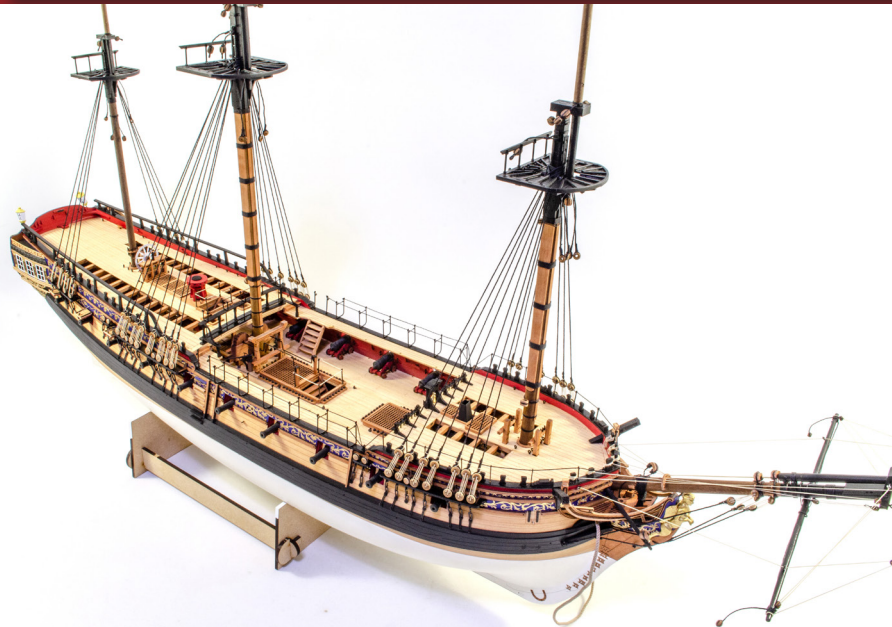
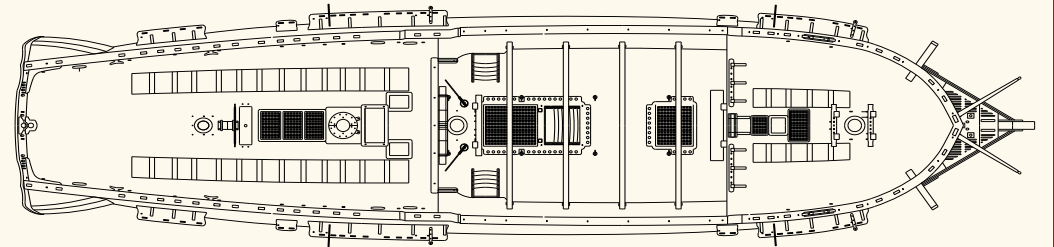
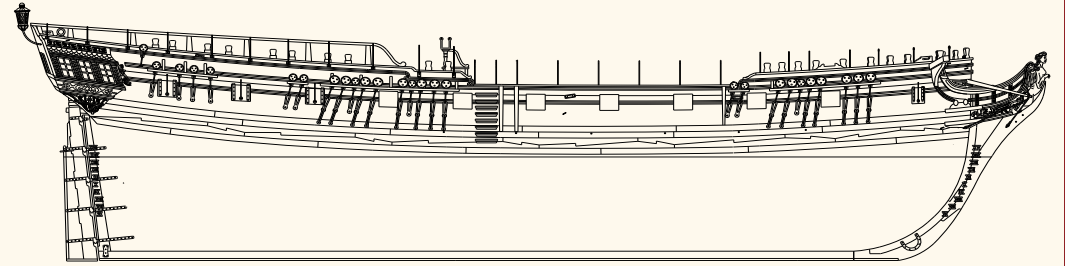

VANGUARD MODELS
BY CHRIS WATTON

THE 20 GUN SIXTH RATE
HMS SPHINX
1775

HISTORY

The Sphinx was the named ship of its class, designed by John Williams in 1773, almost two decades after the last batch of 20 gun ships. This class had finer lines than the earlier designs, but more or less the same layout.

The Sixth Rates were defined as 'Post Ships' because they were the smallest vessels that a posted captain (One with the substantive rank of Captain, rather than a Lieutenant-in-command) was required to command.

While technically not classed as a frigate, in practice they were usually described as such by sea officers. Sphinx was 'frigate-built' with traditional quarterdeck and forecastle. Apart from size, the only structural difference from the larger frigates was the absence of an orlop platform amidships

Sphinx was ordered on 15th April 1773 and built at Portsmouth Royal Dockyard by master shipwright Edward Hunt. She was launched on 25th October 1775, with a cost of £7,494.5.1d to build and another £2,704.0.5d for fitting out. She seems to have been commissioned immediately after launch and fitting out in October 1775.

Her dimensions were:

Length of Gun deck - 108'
Length of Keel - 89' 7 3/8"
Breadth - 30' 1"
Depth in Hold - 9' 8"
Burthen - 431 37/94Tons

Armament

Broadside Weight = 90 Pounds (40.815 kg)
Upper Gun Deck - 20 British Armstrong 9-Pounder carriage guns

Later vessels were re-classed as 24 gun Sixth Rates, with 4x4-Pounder carriage guns or early 12-Pounder carronades on the quarterdeck, and some were converted to bomb vessels.

Crew Complement (1775) - 140 officers and men, which was increased later when some of the class had more guns added.

When first commissioned, Sphinx was sent to the North American station. She was captured by the French in September 1779, and renamed 'Le Sphinx', but retaken 3 months later in December 1779. She was paid off in 1781 and underwent a Middling Repair, coppered and fitted at Deptford. She was recommissioned early in 1782 for convoys in Home waters, and paid off again in 1783. From June 1783 to 1786, Sphinx was operating in the Mediterranean.

Sphinx was paid off again in October 1786, and between December 1788 and May 1789, she had a 'Between Middling and Great Repair' at Woolwich. This cost £6,979, with a further cost of £3,259 for fitting out.

She was recommissioned again on 7th September 1790 under Captain George Tripp, and paid off in June 1792. Sphinx was refitted by Dudman, Deptford for £1,108 on 2nd March 1793, and completed fitting out in Woolwich for £2,137. In May 1793, she was recommissioned under Captain Richard Lucas. Sphinx took the 18 gun La Trompeuse off Cape Clear on 12th January 1794. Later that year, she was recommissioned under Captain Charles Mansfield, where Sphinx sailed for the East Indies station in April 1795. In 1796, under the command of Andrew Todd, she joined Elphinstone's squadron at the Cape of Good Hope, and was present at the surrender of the Dutch squadron at Saldanha Bay on 17th August 1796, and later that year the capture of a French settlement at Foul Point, Madagascar.

Sphinx stayed in the East Indies until 1799, when she sailed home to England and then put into ordinary. She lasted until June 1811, when she was broken up at Portsmouth, after 36 years of service.

THE KIT

Sphinx kit has been researched to depict her as per the original plans, copies of which were obtained from the National Maritime Museum in Greenwich, UK.

Although the kit has many parts, this does not mean it is more complicated than standard kits you may be used to. It simply means that more parts are pre-made/cut than most other kits, meaning you do not have to manufacture the parts yourself from wood stock supplied in the kit.

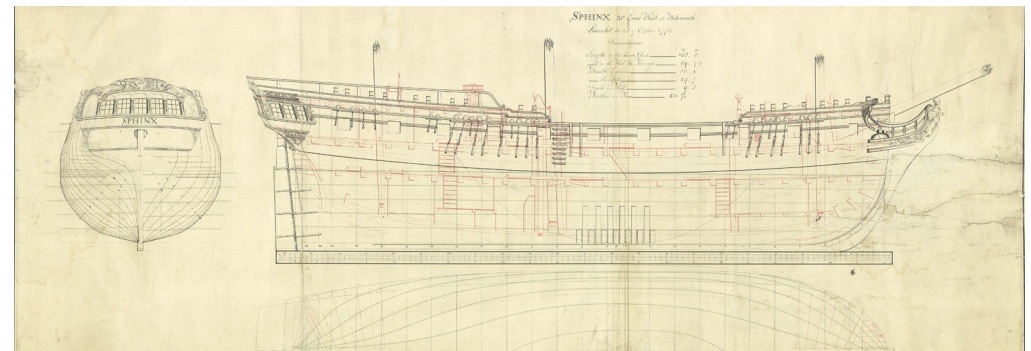

The forecastle and quarterdeck is designed to allow the gun deck detail to be shown, and so has true scale and spaced deck beams.

This model kit is designed to be as accurate as possible for a commercial kit in both scale and detail. Although HMS Sphinx is as easy to build as we can make it, very basic woodworking skills (and patience) are still required. Estimated build time is between 400 to 800 hours, so a work space will have to be put aside for the job. Do not remove parts from the laser cut sheets until actually required for fitting, as they can be easily damaged or lost. Do not glue any wood parts when they are still wet from the bending process, as the wood expands greatly when holding water, and will shrink back to normal size when dry. We recommend all planks and laser cut parts that require bending, are 'pre-bent' before gluing.

PLEASE NOTE - This is very important.

Several major wood parts to be bent are to be soaked and clamped in place until thoroughly dry. Certain woods expand a lot when wet or even damp, so if you glue wood parts that still contain moisture, they will continue to shrink while until completely dry. Take plenty of time to study this manual until you are confident enough to tackle each stage of construction. Patience is the key word when building any scale model. Treat each stage as a separate project and the overall effect of the completed subject will be much enhanced.

Care should be taken when cutting parts from the laser and brass etched sheets. The sheet from which you are going to cut the parts should be laid on a hard, flat surface. Use a heavy-duty craft knife (a Stanley Knife is perfect and is and always has been my staple for all manner of cutting) with a good strong blade to cut through the tabs holding the parts in place. Before removing the wooden parts from their sheets, they should be numbered by reference to the cut file identification drawings. It is easier to paint most of the photo-etched parts before removing them from their sheets. They can be touched up again once in place on the model. When painting parts in wood, use multiple coats with fine sanding in-between each coat to help minimise the grain visibility. Never settle on just a single coat, but instead take your time with every single sub assembly. Consider using a coat of flat varnish under your paint too.

We have included a building cradle on the 3mm MDF laser sheet that is for use when building the model, marking the waterline etc. Do not make up the clear acetate cradle until the model is complete.

Any heat discolouration due to laser cutting/engraving can usually be removed with a very light surface sanding with 320/400 grit, being careful not to damage engraved detail. Then to use a stiff brush to remove any dust from engraved details afterwards.

Recommended tool list

(All items listed were used by the modeller to build the HMS Sphinx prototype model)

- 1: Craft knife (or standard Stanley Knife, which is robust enough for most jobs)
- 2: A selection of needle files
- 3: Razor saw
- 4: Pin vice or small electric drill.
- 5: Selection of drill bits from 0.5mm to 4mm
- 6: Selection of abrasive paper and sanding block (110, 180, 240, 320, 400)
- 7: Selection of good quality paint brushes
- 8: Pliers/wire cutters (Good quality side-cutters are excellent for trimming rigging ends)
- 9: Good quality set of tweezers (For small parts and rigging)
- 10: Steel ruler (300mm - for providing a straight edge for tapering the planking)
- 11: Clothes pegs or small clamps
- 12: Good quality pencil or drawing pen
- 13: Masking tape
- 14: Waterline marking tool
- 15: A Pin Pusher
- 16: Cutting mat

Although not strictly required, access to a lathe would be very beneficial for turning the upper masts and yards, although the yards are easily tapered using a small wood plane and abrasive paper to smooth the surface.

Recommended tools from Vanguard Models



Our waterline marking tool is supplied in a sheet of laser-cut, 4mm plywood that needs assembly. Assembly time is around 15 minutes and very easy. Metal fittings are supplied to aid the change in position of the pencil carriage. Vanguard Models pencil is supplied with each tool.

The Waterline Marker will mark a level from between 25mm to 150mm, and an engraved gauge will help you achieve the correct level.



Pin Pusher With Adjustable Depth Stop

This is a slightly larger version of our other pin pusher, and has the added advantage of an adjustable depth stop to ensure that all pins are pushed 'home' to the same depth. It is ideal for model boat/ship hull planking, and setting miniature n-gauge rail track on to board, or for nailing tasks on wooden boat models, dolls houses and picture frames.



Pocket sized Pin Pusher

Can push pins in to 9 mm of plywood or MDF
Ideal for pushing brass pins
Nailing, pin pushing or riveting can be frustrating if the wrong type or an oversized hammer is used. Not to mention the dangers involved. Small pins and nails should be driven in using a precision tool rather than a regular DIY hammer. Pin pushers will make inserting small panel pins and nails a breeze and virtually eliminate sore thumbs!



This plank bending tool is the ideal boat modeller's tool for the bending strips to the desired curvature. Used for perfect and precise bending of all wooden strips, such as planking on model boats up to 2mm thickness. For bending at an angle, change the cutting angle and the plank will 'spiral'. The more cuts produced the tighter the bend. Includes a plastic blade stopper.





Ideal for bending planking strips to the desired curvature
 Modelcraft Plank Bending Tool Kit 220-240v, 30w

- The Plank Bending tool is ideal for bending planking strips to the desired curvature
- The rounded head on the tool should be warmed up and the wooden strip should be placed on the wooden template form. The strip is then heated by running the tool head over it a few times until the required curve is achieved.
- It works on dry strips with a maximum thickness of 1mm
- For thickness over 1mm, the strip must be dampened
- Set includes: Tool with a rounded head, tool stand & wooden template form.
- Use with caution as parts will be hot



Spring-Loaded Finger Sanders available in 4 sizes, 10mm, 20mm, 25mm, 40mm (Medium Grade)
 Unique shape for flat and curved surfaces
 Easy to fit band with spring mechanism

These sanders have a unique shape for working on both flat and curved surfaces and come with pre-fitted medium sander band. The sanders also have an ergonomic shape meaning that they're comfortable when in use.

Flexible Masking Tape x2

This is available in TWO sizes, and there are two rolls in each packet.

3mm wide x 18m long
 6mm wide x 18m long

Absolutely ideal for masking hull waterlines! These masking tapes are also ideal for general modelling, airbrushing, arts, crafts, and even those smaller DIY tasks. The tape sticks, stays and removes cleanly. This flexible acid-free tape is designed to follow curved lines and contoured surfaces without creasing, tearing or paint bleed.

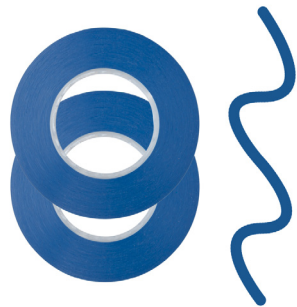

Recommended Paints, stains and adhesives

- 1: White PVA wood glue or suitable Titebond adhesive.
- 2: Cyanoacrylate (superglue) thick and medium viscosity
- 3: Natural colour wood filler (Water based wood filler is recommended as this can be diluted and made thinner)
- 4: Matt polyurethane varnish (Not satin or gloss)
- 5: Black paint (Humbrol 85 or Vallejo Matt Black)
- 6: Gold paint (Vallejo Liquid Gold, thinned with isopropyl alcohol)
- 7: Red paint (Vallejo acrylic)
- 8: White Paint (For hull below waterline)
- 9: Blue paint (Humbrol 25)
- 10: Metal burnishing/blackening liquid (AK Interactive AK 174 - brass Photo etch Burnishing) or similar
- 11: Clear Epoxy Resin or similar to glue the clear acetate stand, together
12. Iron or Steel pigment powder.



HULL CONSTRUCTION

Building the cradle

1. Remove all parts from the sheets using a sharp knife such as a Stanley knife or a good hobby knife such as a Swann Morton scalpel etc. You may need to cut tabs from both sides of the sheet, depending on thickness of material.

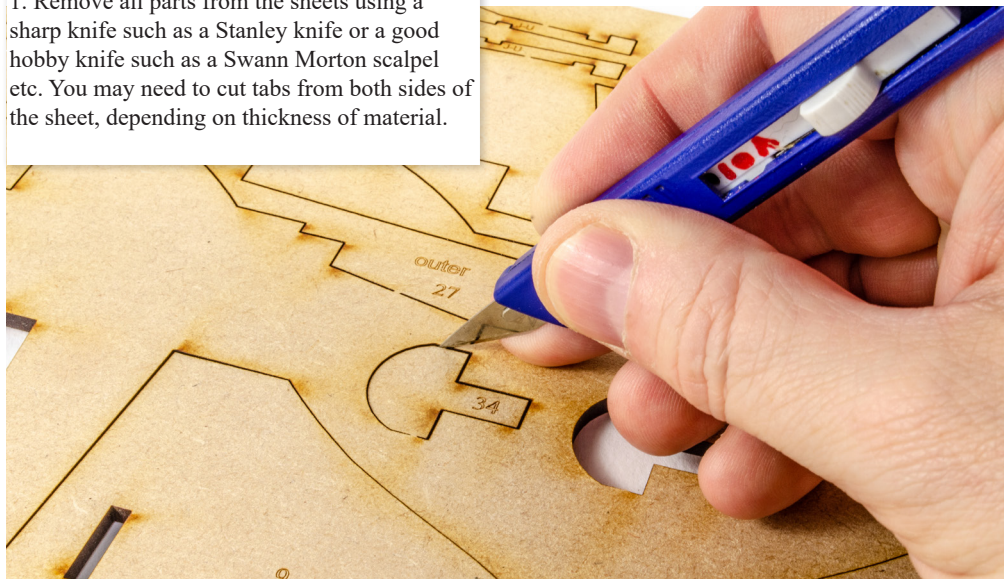

2. When you have removed parts from a sheet, it is good practice to use a knife or sanding paper/ stick to remove any nub that might remain.

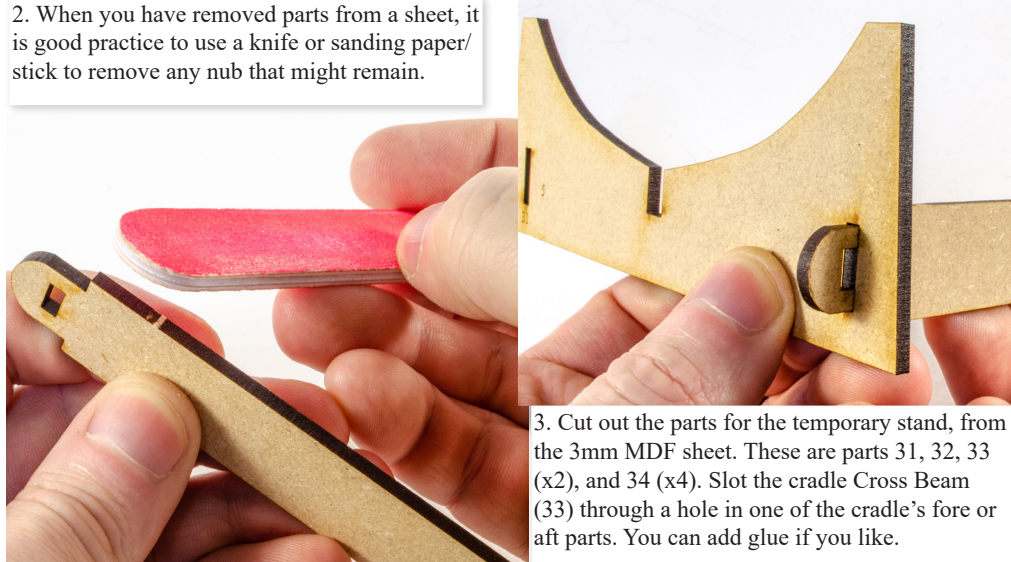

3. Cut out the parts for the temporary stand, from the 3mm MDF sheet. These are parts 31, 32, 33 (x2), and 34 (x4). Slot the cradle Cross Beam (33) through a hole in one of the cradle's fore or aft parts. You can add glue if you like.

4. Next, add some glue to a Securing Peg (34), and push through the hole in the cross beam. Do this for all four corners of the cradle. There is only one way this can be assembled.



The completed cradle.

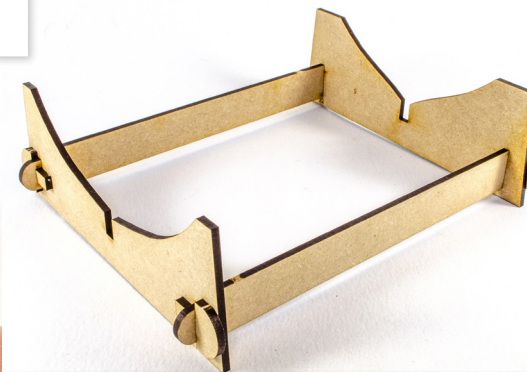

5. Your cradle is now ready to use. Remember, this is only to be used while you build your HMS Sphinx, and it can be discarded when complete.

6. Building the hull

From the 4mm MDF sheet, remove parts 13-1 (Rear Bulkhead) and 13a, 13b, 13c, 13d, 13e, and 13f (Stern Transom Patterns).

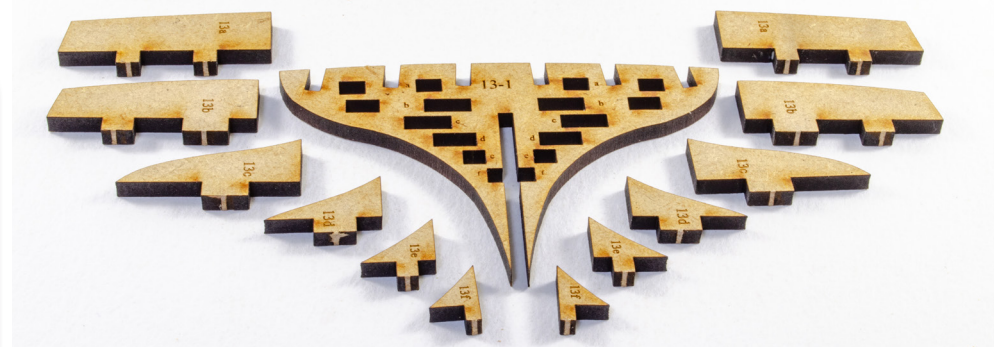

7. Note how the rear bulkhead is engraved with the positions of the stern transom parts.

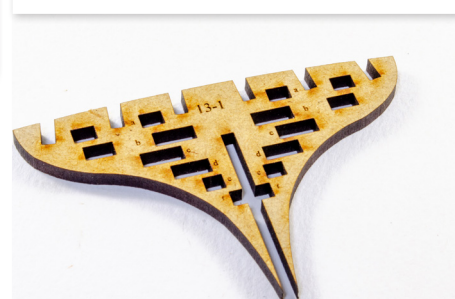

8. Glue each of the stern transom patterns into its respective slot on the rear bulkhead and set aside to thoroughly dry.



9. Remove the keel pattern (0) from the 3mm MDF sheet.

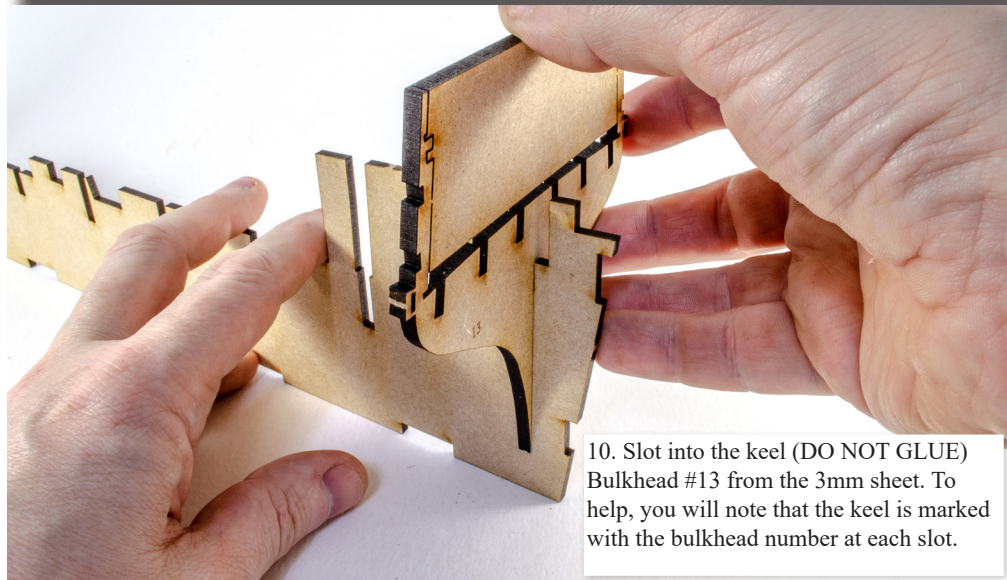
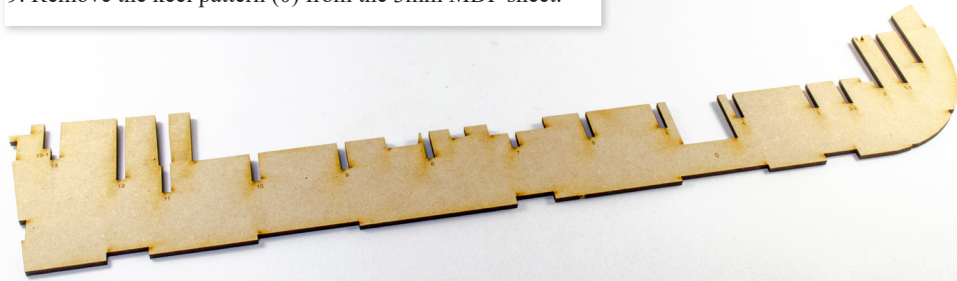

10. Slot into the keel (DO NOT GLUE) Bulkhead #13 from the 3mm sheet. To help, you will note that the keel is marked with the bulkhead number at each slot.

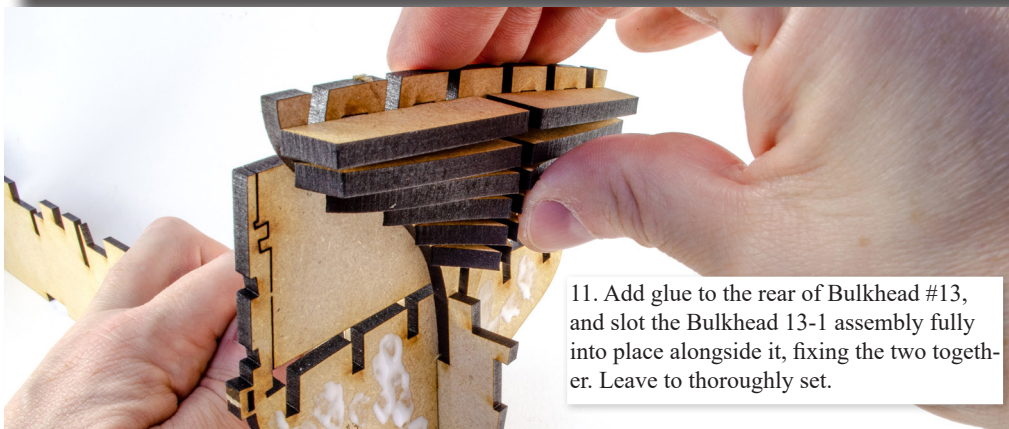

11. Add glue to the rear of Bulkhead #13, and slot the Bulkhead 13-1 assembly fully into place alongside it, fixing the two together. Leave to thoroughly set.

12. Leave the glue to thoroughly set.

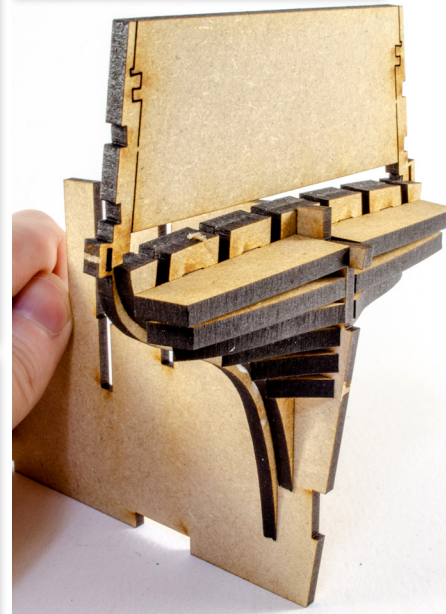

13. Remove the two Stern Planking Patterns (24) from the 3mm MDF sheet.



14. Glue the two Stern Planking Patterns (24) into position on the stern assembly as shown. DO NOT glue these to the keel, ONLY onto the previous assembly.



15. Remove the stern assembly from the keel.

16. Use a sanding block and/or rotary tool to shape the stern assembly. We really do recommend the rotary tool for this as it's so much quicker and easier. Note the tape that's added to the bulkhead. This is to stop the modeller accidentally twisting away the infill area while shaping the assembly.

NOTE: Please wear a suitable mask when sanding MDF!

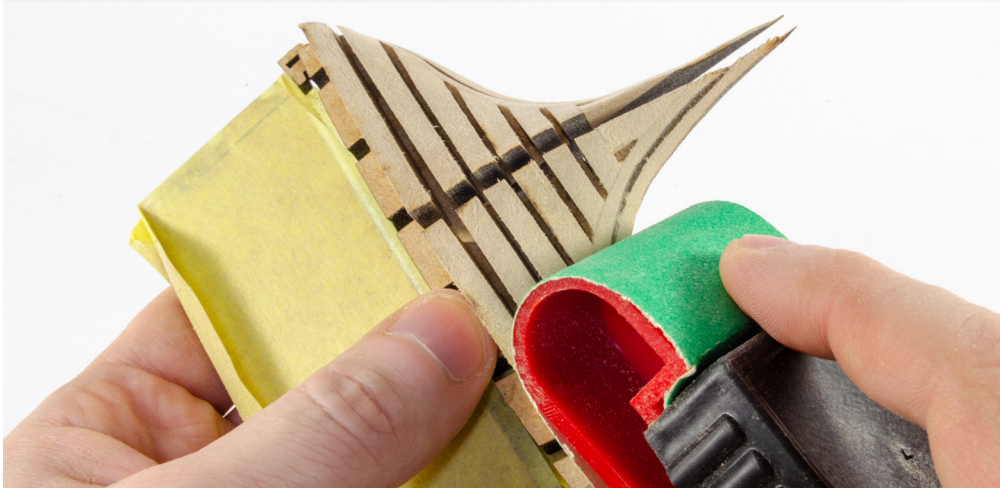

17. Here you can see how the keel pattern has numbers adjacent to the bulkhead slots, as mentioned earlier. We'll now build a bow assembly around Bulkhead #1.



18. From the 4mm MDF sheet, remove Bulkhead #1 and the Bow Frame Patterns (2 x 1a – Inner, 2 x 1b – Middle, 2 x 1c – Outer, and 2 x 18 – Bow Curve Pattern - Parts 18 may be incorrectly numbered as Parts 1e on your laser cut 4mm sheet).

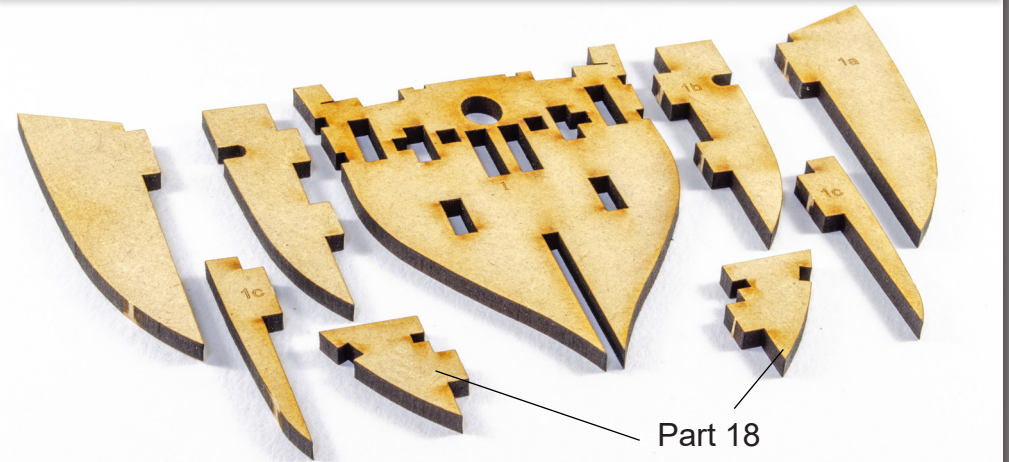

19. Slot (DO NOT GLUE) Bulkhead #1 onto the keel.

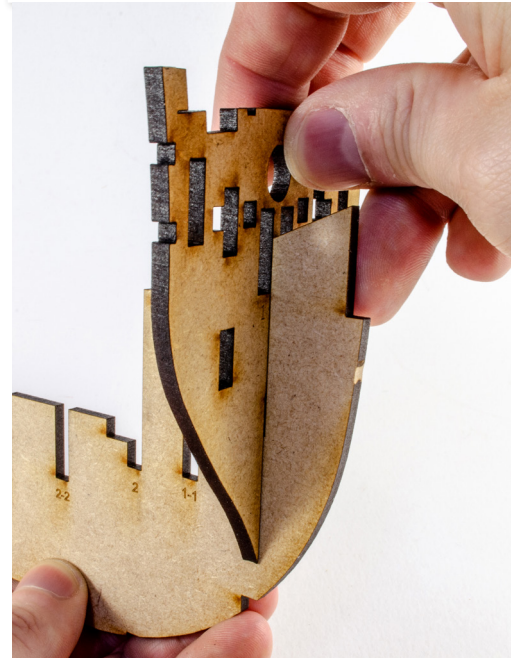

20. Add glue to the straight edge on parts 1a.

21. Fit them to the inner slots on Bulkhead #1. Again, do NOT glue to the keel.



22. Now glue parts 1b and 1c to the slots on each side of Bulkhead #1. The clamp you see is being used to make sure the inner parts 1a are both up against the keel, whilst the bulkhead is at 90 degrees to the keel.



23. Parts 18 are now glued into position as shown here.

24. The bow assembly can now be removed from the keel. Ensure all glue is thoroughly dry.



25. Use a sanding block and/or rotary tool to shape the bow assembly. This one is a little easier than the stern for shaping.

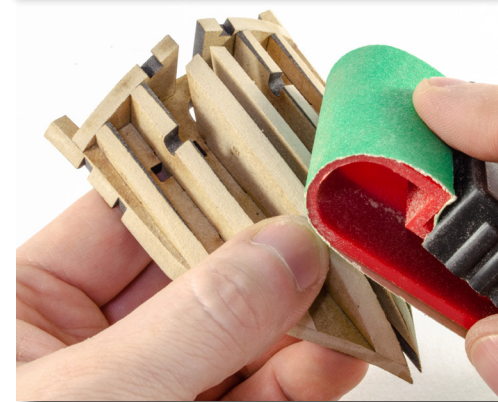

26. Both the bow and stern assemblies are now complete. If you added tape to the stern assembly, you can now safely remove it.

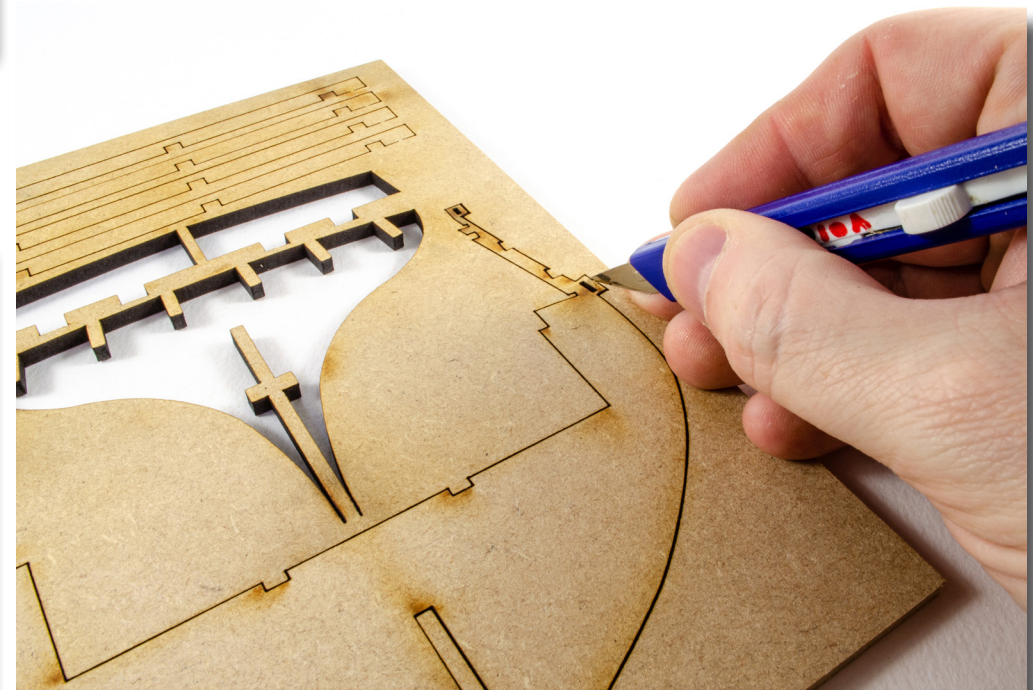

27. Cut all bulkheads from the 4mm MDF sheet. NOTE: You will see the fragile bulkhead ears are protected by a small 'safety gate' on the outer edge of the part. This gives extra strength to these areas. The gate can be seen next to the knife blade in this photo.

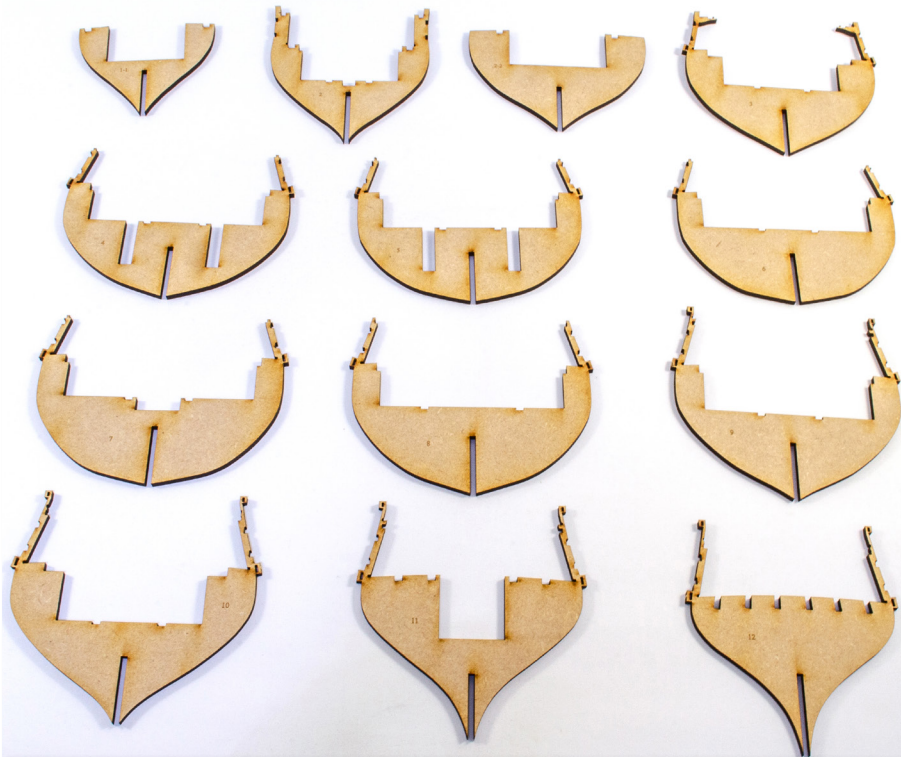

28. There are thirteen bulkheads to remove from the 4mm MDF sheet (1-1, 2, 2-2, 3, 4, 5, 6, 7, 8, 9, 10, 11 and 12).

30. Now slot bulkheads 5, 6, 7, and 8 into position. Again, do not glue yet.



29. Slot bulkheads 1-1, 2, 2-2, 3 and 4 into position. Handle these gently as mishandling could damage the ears. Do NOT glue at this time.



31. Lastly, slot (not glue) bulkheads 9, 10, 11 and 12 into their correct slots on the keel. If you wish, you can leave off bulkhead #12 at this stage and fit along with the bow and stern assemblies.



32. Remove the Orlop Section (39) from the 2mm ply sheet. This part is engraved with deck planks.



33. Making sure the bulkheads are fully seated, glue the orlop into position between bulkheads #4 and #5. Leave to dry.

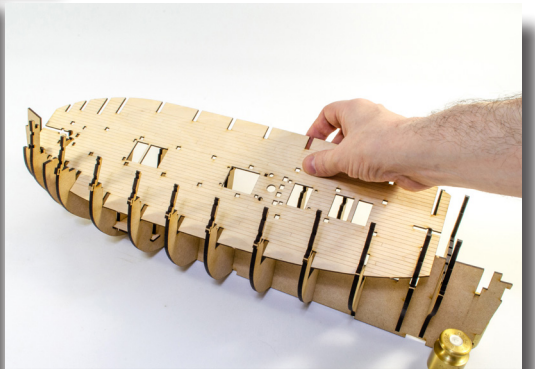

35. Carefully slot the deck into position as shown here, taking care not to damage the bulkhead ears. Do NOT glue yet.

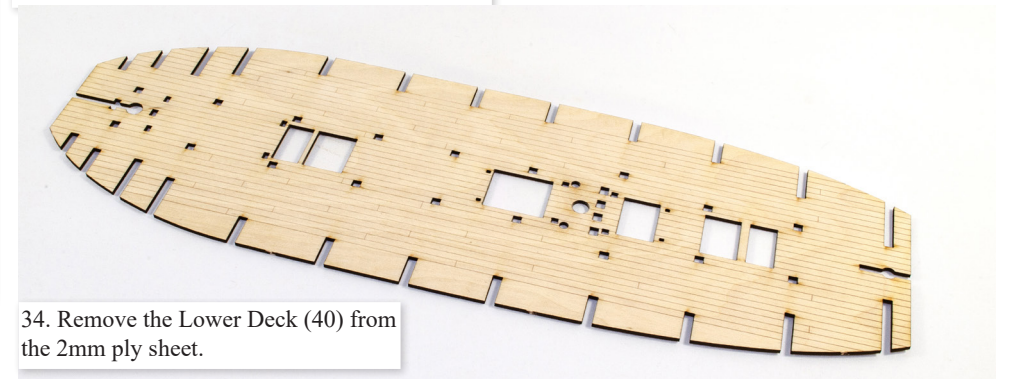

34. Remove the Lower Deck (40) from the 2mm ply sheet.

36. When slotted into position, the hull will look like this.

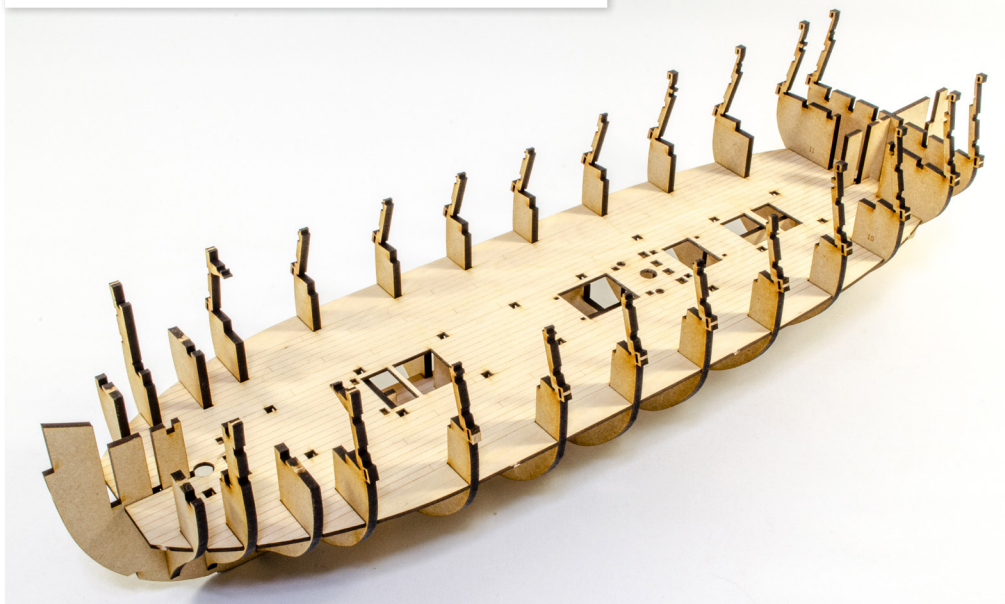

38. Turn the hull the right way up and slot/glue the bow assembly into place on keel slot #1.



39. Now fit and glue the stern assembly into position on keel slots 13/13-1. If you previously left bulkhead #12 off the hull, you can now fit and glue this into place too.



37. Turn the hull upside down and rest the lower deck on two items of similar size (paint tins etc). This will trip the bulkheads in position so you can paint wood glue into the joints between the deck, bulkheads, and keel. We find it's useful to slightly dilute the glue with water to make easier to apply with a brush. Leave the hull overnight to dry.

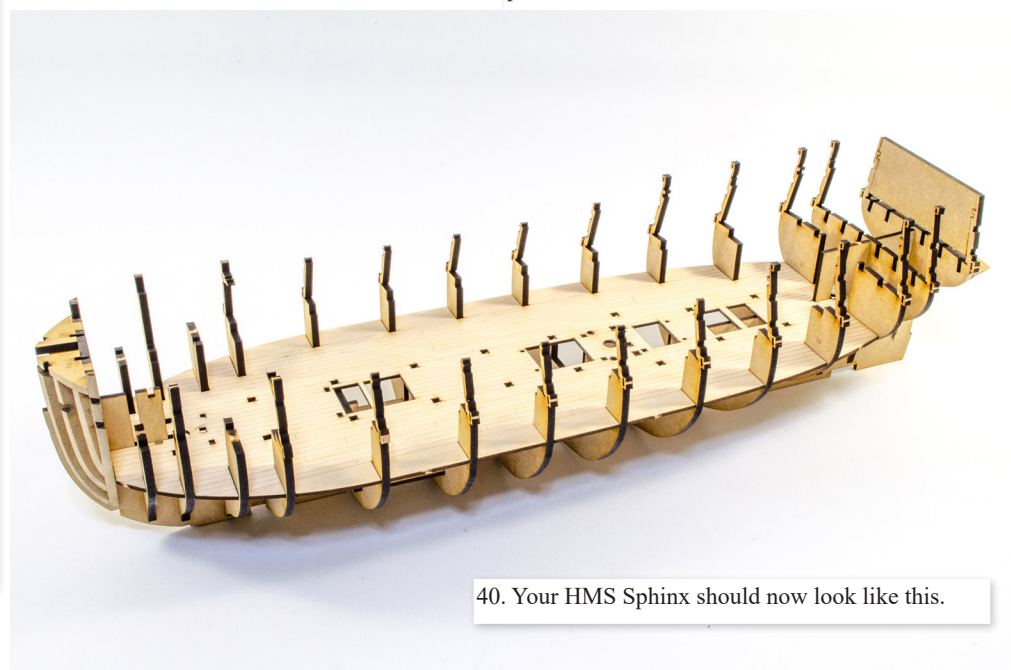

40. Your HMS Sphinx should now look like this.

41. Cut the two Longitudinal Gun Port Frames – Lower (35) and the two Longitudinal Gun Port Frames – upper (36) from the 3mm MDF sheet. Please treat these delicate parts with care.



42. The upper and lower strips are engraved with the identification, so they are easier to identify.

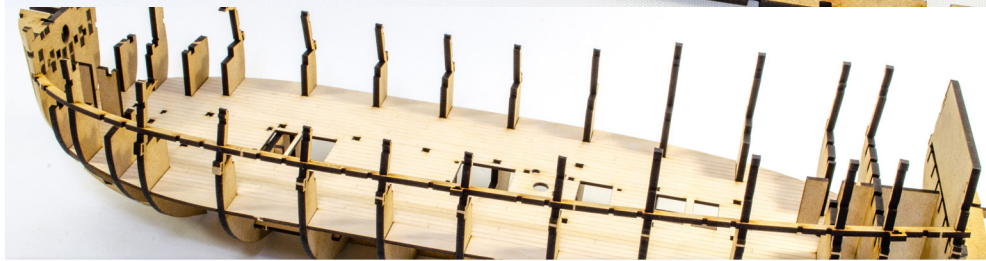

43. Take one of the Longitudinal Gun Port Frames – Lower (labelled 'BOTTOM') and fit it along the lower of the slots in the bulkhead ears. The strip will start at the first bulkhead and fit across every single one, right to the last bulkhead. Be gentle when you fit this. Do NOT glue yet.

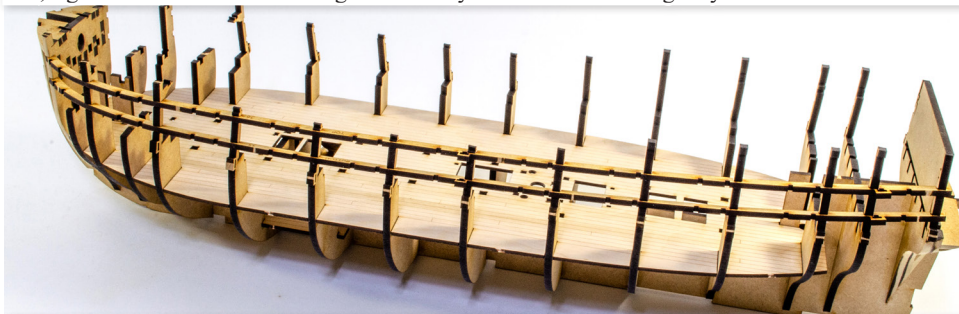

44. Now take the two Longitudinal Gun Port Frames – Upper (labelled 'TOP') and fit into the slots above the first strip, again, running full length of the hull.

45. Once both are in position and pushed fully into the bulkhead slots, brush a little dilute wood glue into each joint and leave to dry. Once the glue is set, fit the two Longitudinal Gun Port Frames to the other side of the hull, in the same way. Here you can see the labelled strips in place.

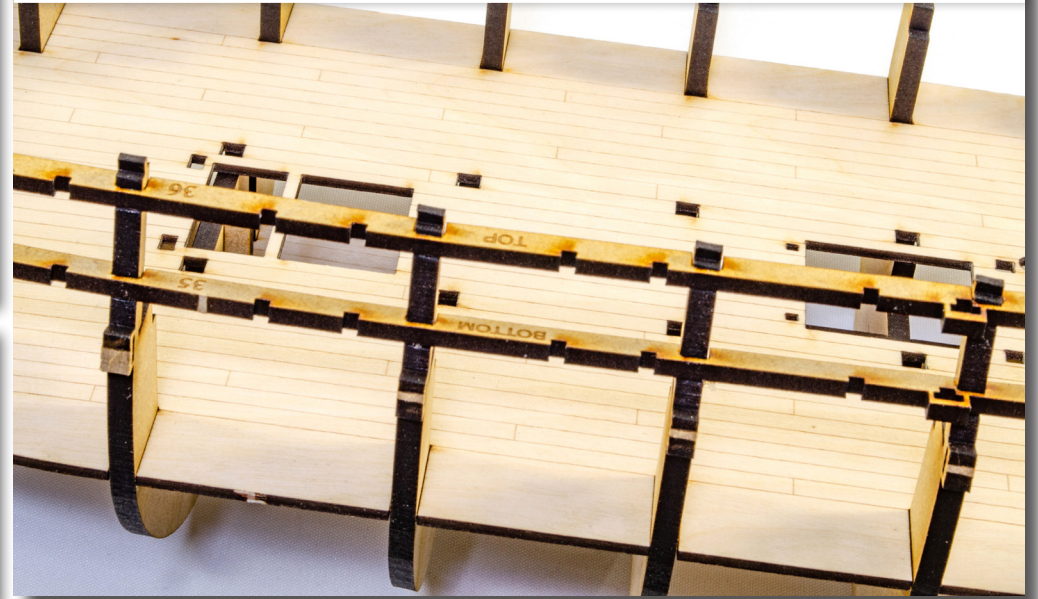

46. When fitted, your HMS Sphinx hull will look like this and is now becoming a lot stronger.

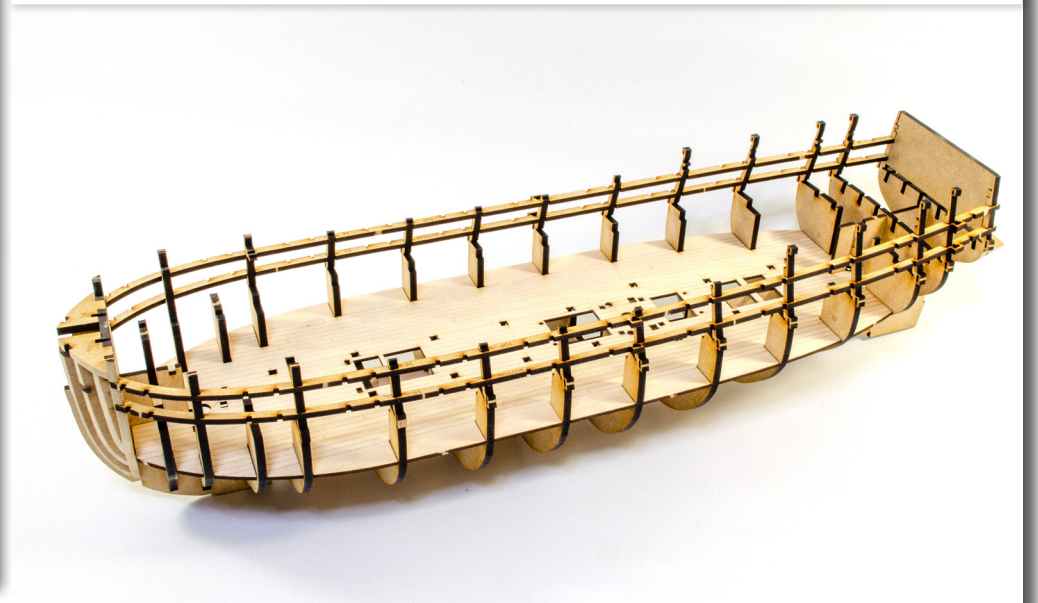

47. As Bulkhead #13 is now protected by the strips you just fitted, the infill piece can be removed. For this, cut the tabs on each side and gently twist back and forward until it comes away.

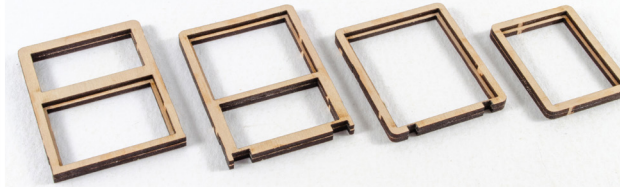

50. When each completed coaming is dry, sand the edges to remove the laser char. Also remove the laser char in inside the two smaller openings of the double coamings, as no grate will be fitted in these.



51. Here you can see where each coaming will fit onto the lower deck.

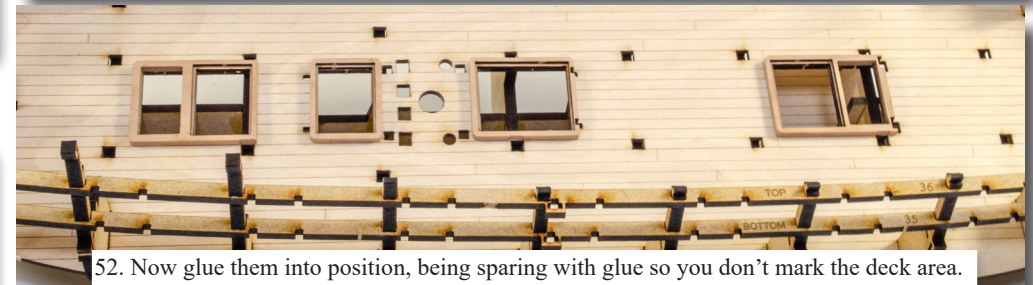

52. Now glue them into position, being sparing with glue so you don't mark the deck area.

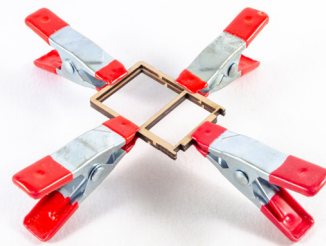
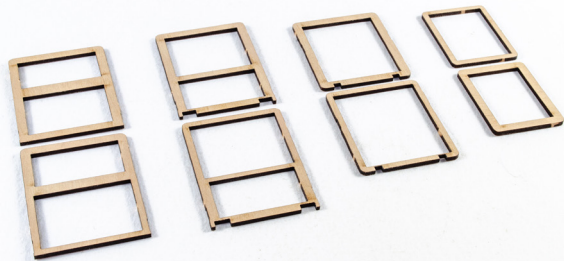

49. Orient each pair correctly and glue them together. Set to one side until dry.

48. Onto a little detailing now as we built the lower deck coamings. From the 1.5mm wood sheet, remove the parts as pairs: (313, 314), (316, 317), (319, 320), and (322, 323). These form the forward, main aft and aftermost coamings.



53. Each coaming has its respective grating, also found on the 1.5mm wood sheet. These are Lower Forward (315), Lower Main (318), Lower Aft (321), and Lower Aftermost (324). These can be glued into position in the coamings.

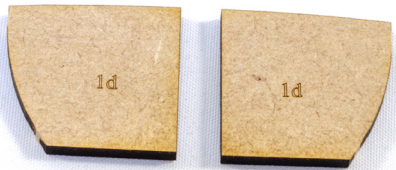

54. We can now start to fit the two Gun Deck Support Patterns (1d). Cut these from the 3mm MDF sheet.

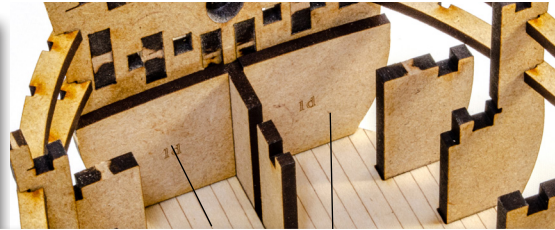

55. Glue both Gun Deck Support Patterns to the back of bulkhead #1, so they sit up against the keel and in the lower deck.

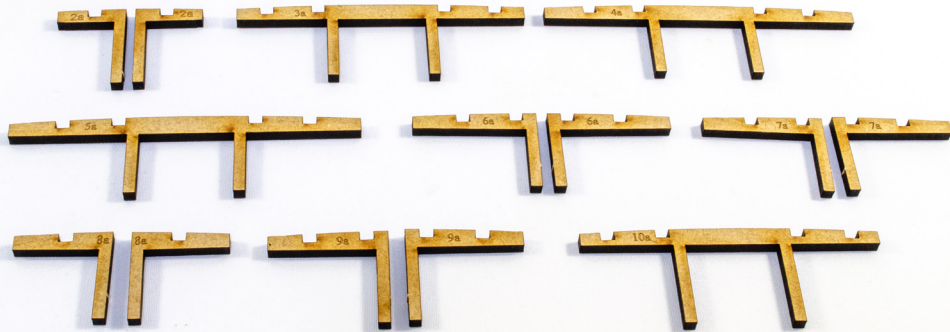

56. All of the gun deck support beams now need to be removed from the 4mm MDF sheet. These are 2a (x2), 3a, 4a, 5a, 6a (x2), 7a (x2), 8a (x2), 9a (x2), and 10a.



57. All the gun deck support beams, whether in two parts or single, push into a hole in the lower deck and also sit on the bulkhead shoulders of the same number, i.e. 4a sits on bulkhead #4. Glue and fit the gun deck support beams for bulkheads 2, 3, 4, 5, and 6 as shown here. Small clamps are used to hold the parts perfectly upright to the bulkhead.

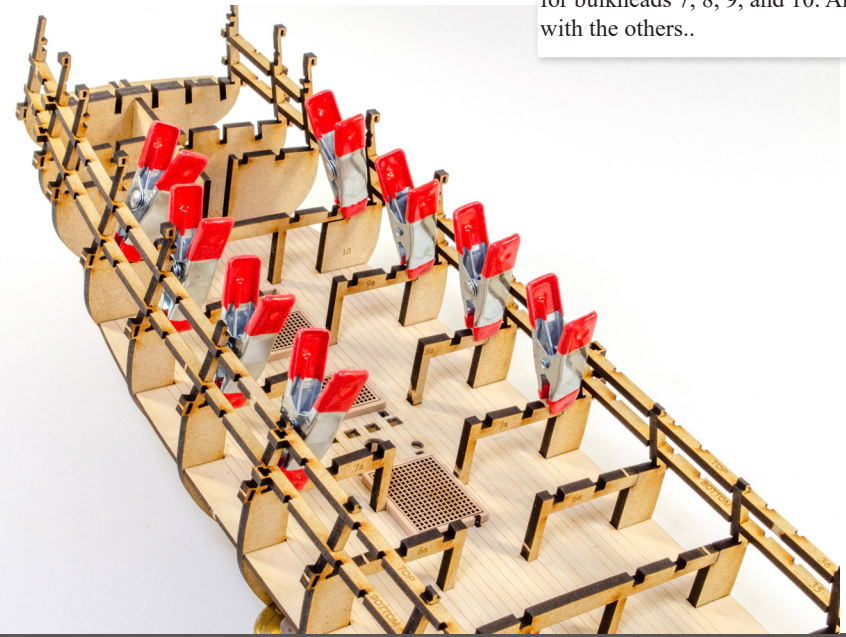

58. Now glue the gun deck support beams for bulkheads 7, 8, 9, and 10. And clamp as with the others..

59. With all gun deck beams in place, your HMS Sphinx will look like this.



60.(Below)Now it's the turn of the inner and outer Longitudinal Deck Beams to be fitted. The two inner beams are #14, and the outer are #15.

61. (Right) They are also engraved with 'INNER' and 'OUTER' so you can't mix them up.

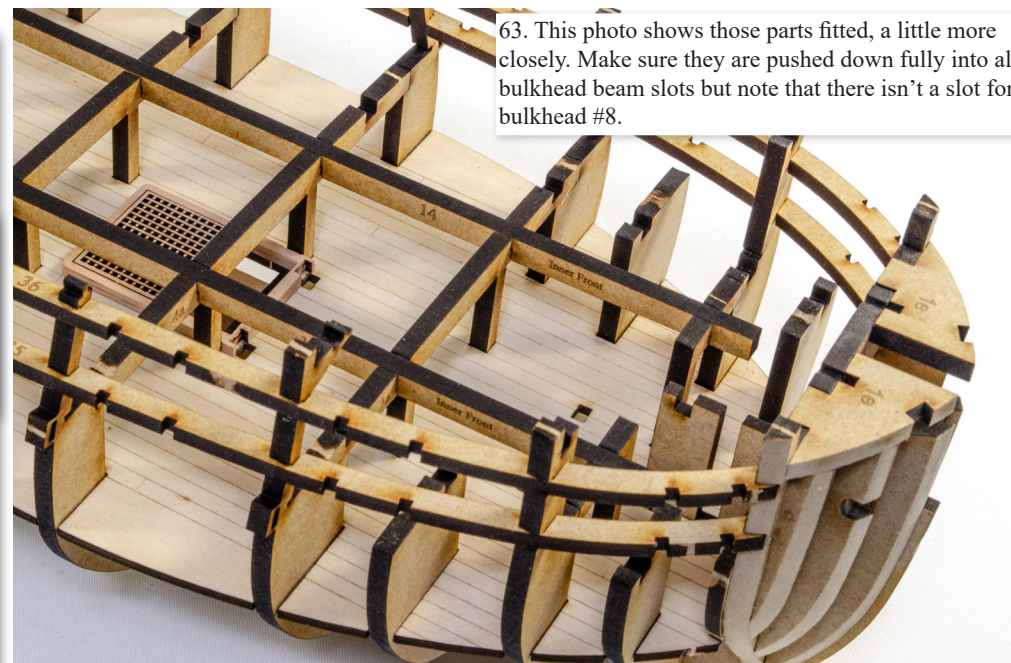
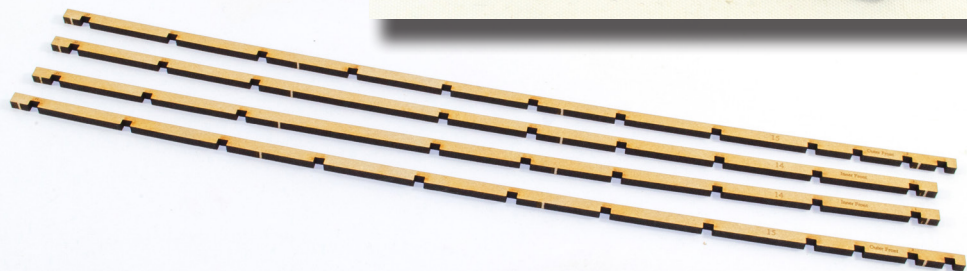
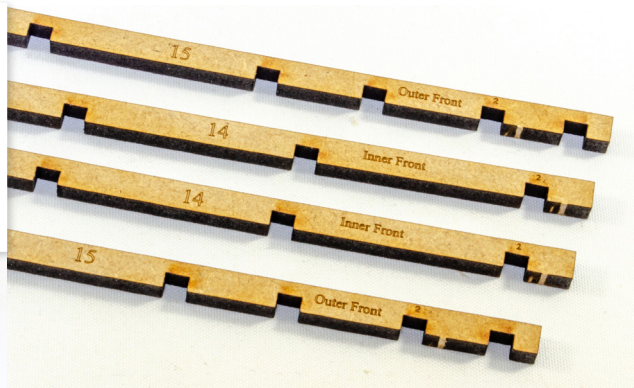

63. This photo shows those parts fitted, a little more closely. Make sure they are pushed down fully into all bulkhead beam slots but note that there isn't a slot for bulkhead #8.

62. Glue the two INNER Longitudinal Deck Beams (#14) into the inner series of slots running across the top of the bulkhead beams, as seen here.

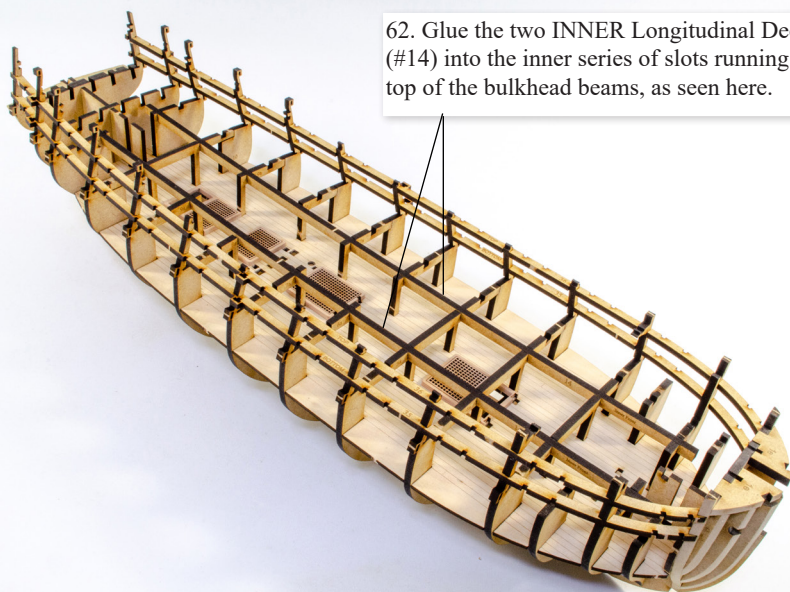

64. The two OUTER Longitudinal Deck Beams can now be glued into the slots adjacent to the inner beams.

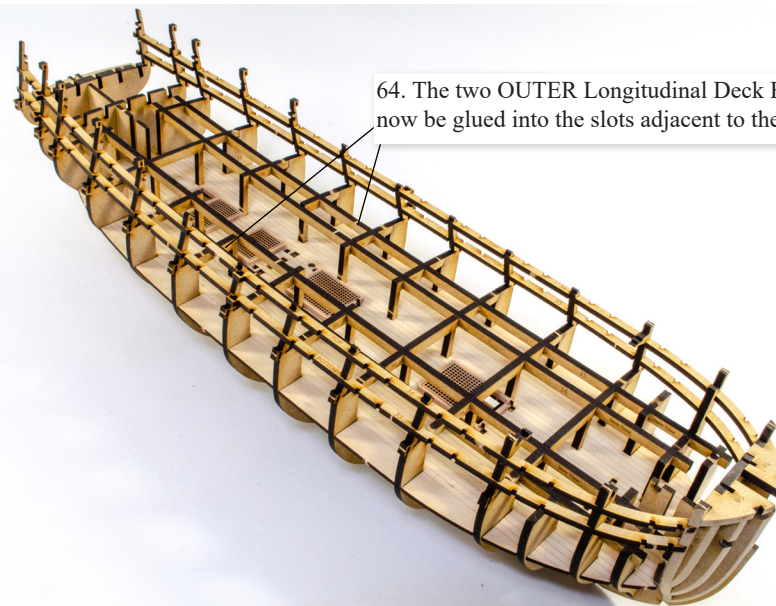

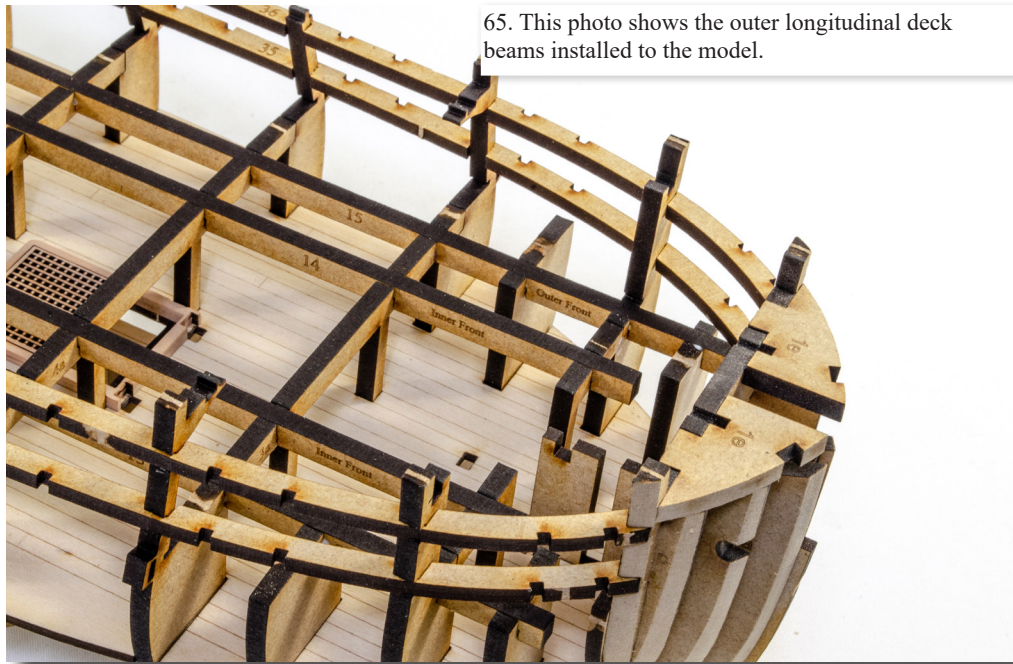

65. This photo shows the outer longitudinal deck beams installed to the model.

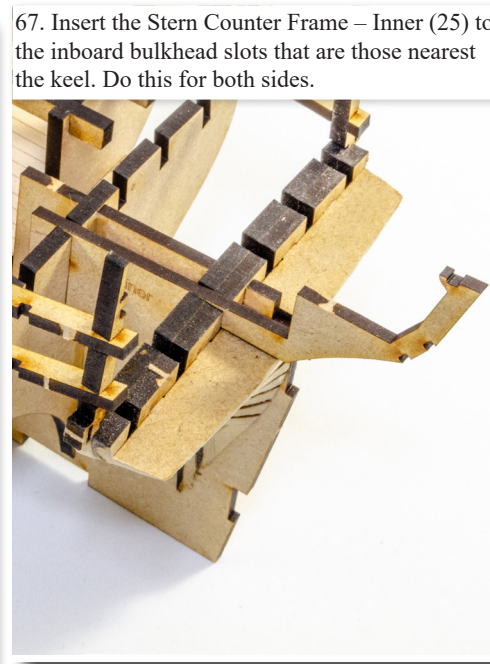

67. Insert the Stern Counter Frame – Inner (25) to the inboard bulkhead slots that are those nearest the keel. Do this for both sides.



68. Insert the Stern Counter Frame – Middle (26) to the bulkhead slots to the outside of the last frame. Do this for both sides.

66. From the 3mm MDF sheet, remove the Stern Counter Frames. There are two each of these (Inner – #25, Middle – #26, Outer – #27, Filler – #28). From the 2mm ply sheet, remove the Stern Frame Spacer Beam (41).

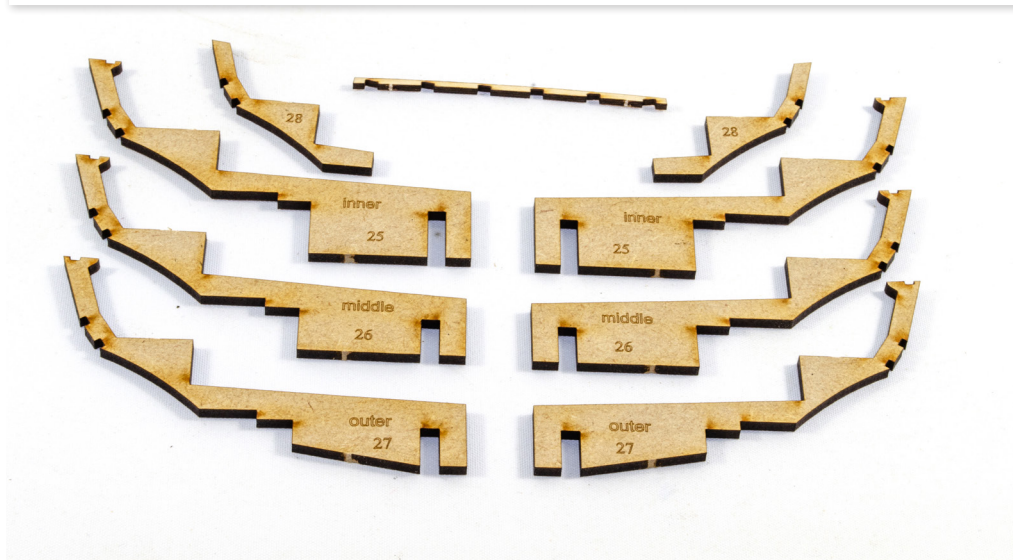

69. Insert the Stern Counter Frame – Outer (27) to the bulkhead slots to the outside of the middle frame. Do this for both sides.



70. Now take the Stern Frame Spacer Beam (41) and glue it to the slots that run along the top of the Stern Counter Frames.



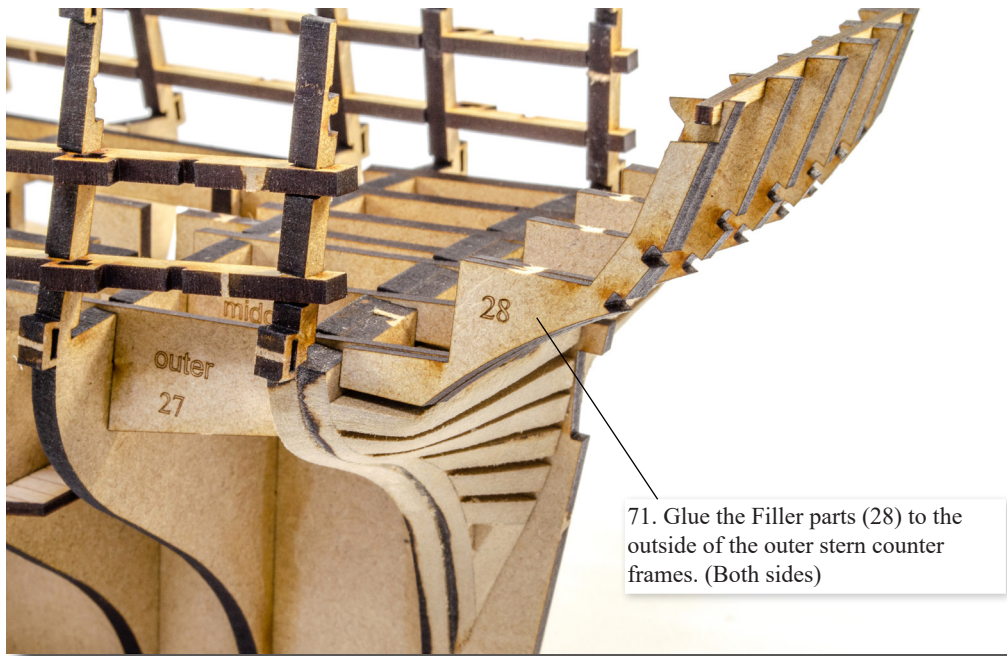

71. Glue the Filler parts (28) to the outside of the outer stern counter frames. (Both sides)

72. Before you attempt to fit the gun deck, sand the horizontal faces of the Stern Counter Frames you just fitted so they flow with the longitudinal deck beams.



73. Remove the two Gun Deck Patterns (47, 48) from the 0.8mm ply sheet. These are actually both the same except for the tabs that align them.

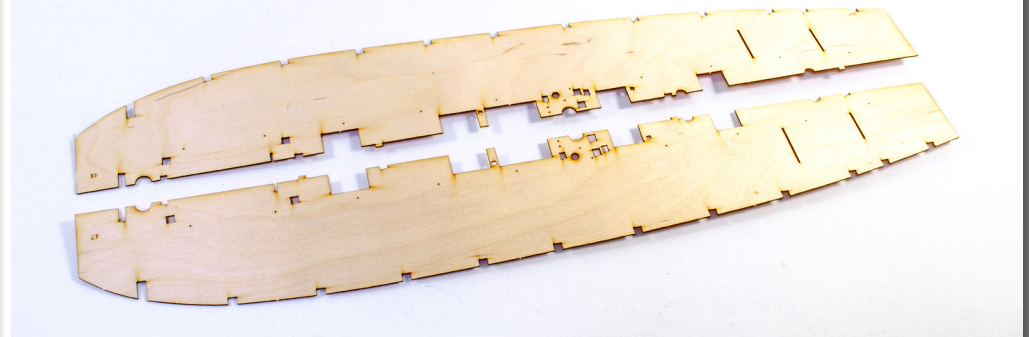

74. Slot Gun Deck Pattern (48) into position as shown. The outside edges of the deck locate into the slots at the bottom of the bulkhead ears, locking the edge in place. You will only need to pin this down towards the centre, with optional pins along the deck beams. You may apply glue first or paint it onto the underside once fitted.

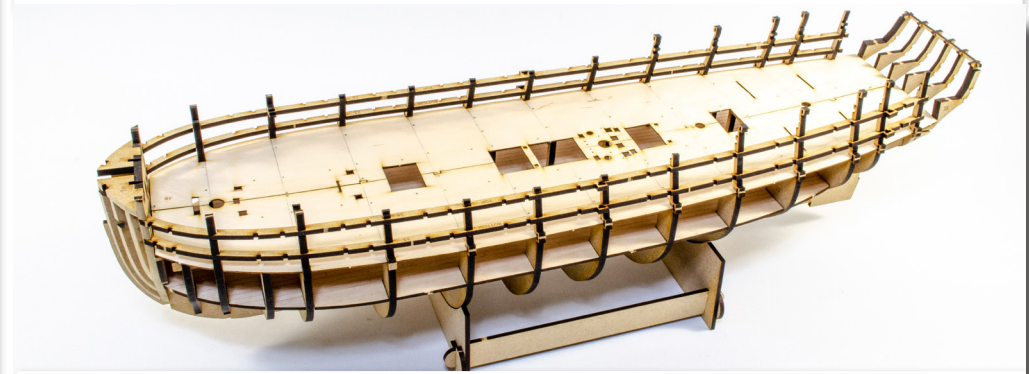

75. Now fit the opposite side of the lower gun deck (47) in the same way. Leave to one side to set.

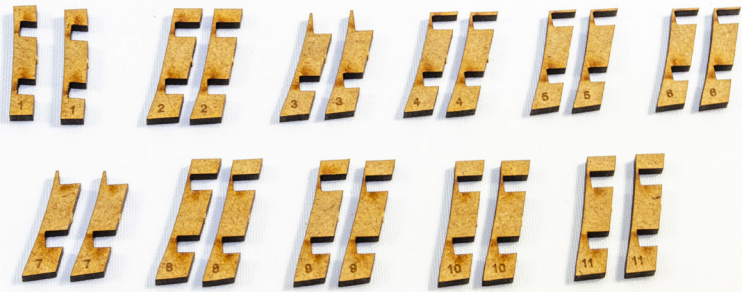

76. The Vertical Gun Port Frames can now be fitted. These are numbered GP1 through to GP11, and there are two sets (port and starboard).



77. Before fitting the frames, snip away the 'safety gates' on the longitudinal gun port strips, as shown here.



78. The Vertical Gun Port Frames glue into the slots between the upper and lower longitudinal gun port strips.

NOTE: Make sure that these pieces are installed perpendicular to the longitudinal gun port strip curve.

Gun port #1 is the forward one, with #11 closest to stern. Here you can see gun ports 1, 2, 3, 4, and 5 installed.



79. In this picture, ports 6, 7, 8, 9, 10, and 11 are clearly seen. Once the glue is set, fit the gun ports to the opposite side of the hull.

80. Once all gun port frames are installed, your HMS Sphinx will look like this.

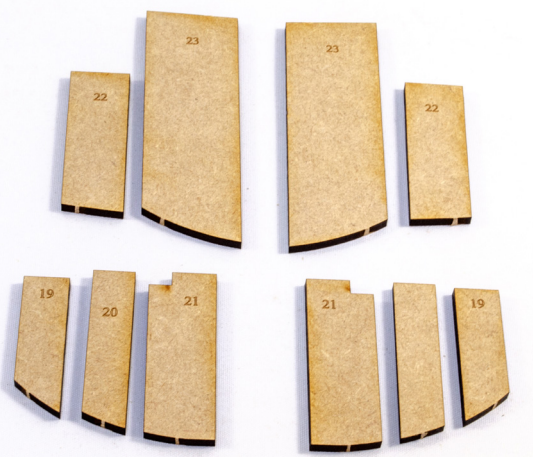
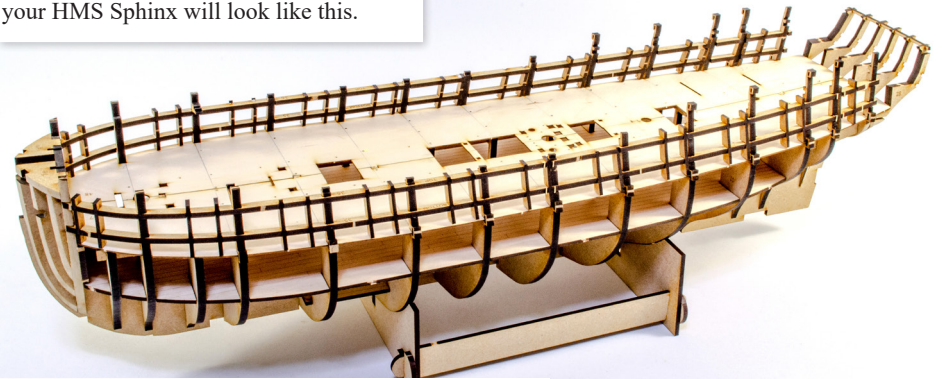

81. Remove the Bow Planking Patterns (19, 20, 21) and the Stern Planking Patterns (22, 23) from the 3mm MDF sheet.



82. Sit the Stern Planking Patterns in place as seen here and use a pencil to mark the bevel lines. Remove the parts from the model.

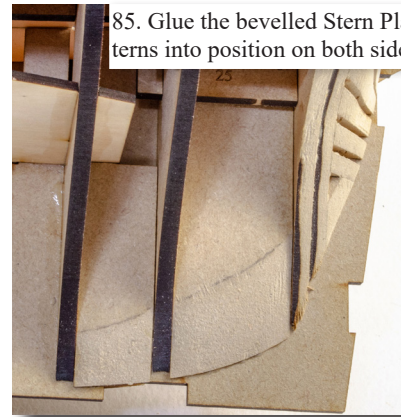

85. Glue the bevelled Stern Planking Patterns into position on both sides.



86. Glue the bevelled Bow Planking Patterns into position on both sides.

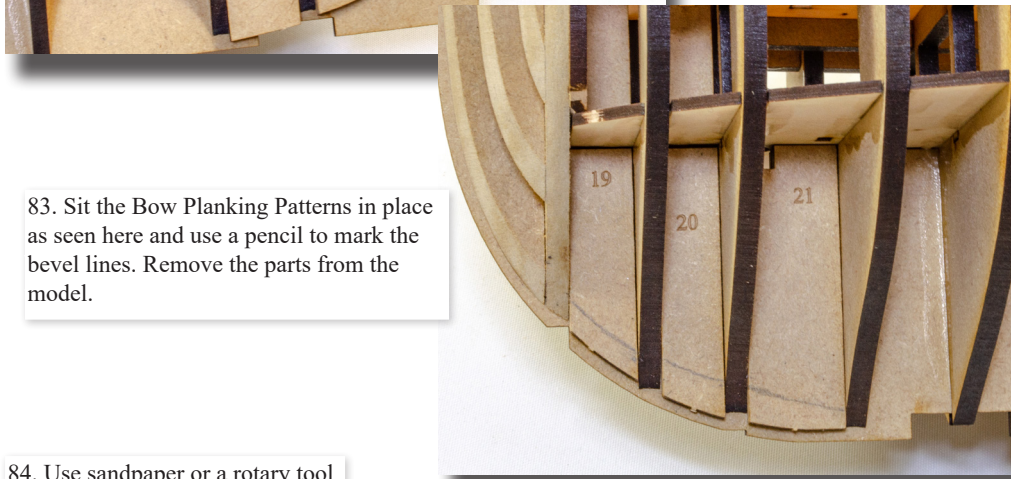

83. Sit the Bow Planking Patterns in place as seen here and use a pencil to mark the bevel lines. Remove the parts from the model.

84. Use sandpaper or a rotary tool to bevel the parts.

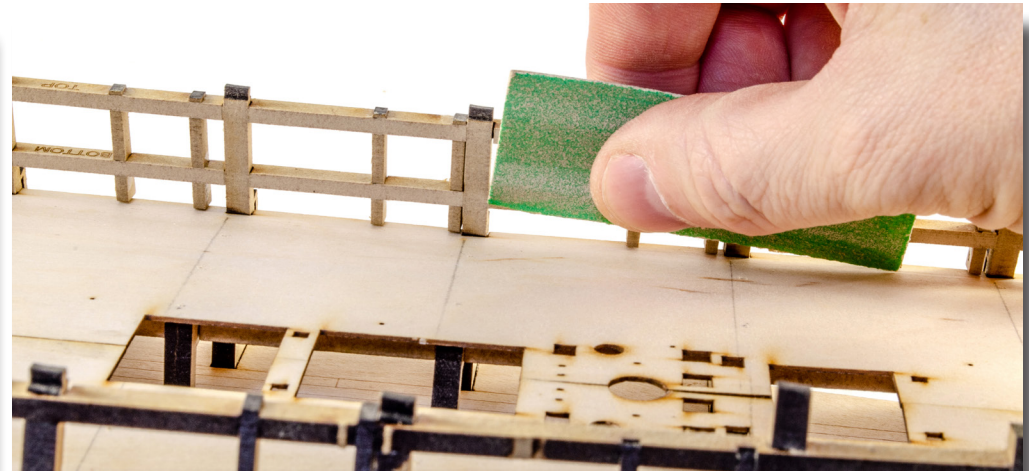
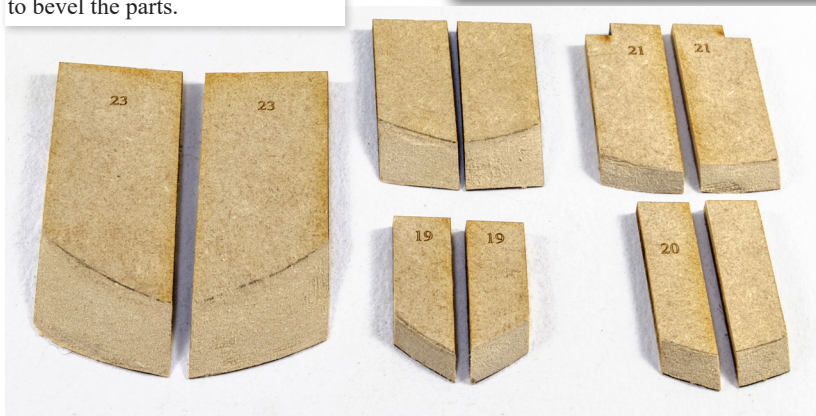

87. Before the inner bulwarks can be fitted to the hull, the inside frames need to be sanded smooth. A good indication of when this is complete is when all the laser char is gone. Make sure the sanding is even all the way along with no dips anywhere.



88. From the 1mm wood sheet, remove the Inner Gundeck Bulwark Pattern – Front Left (213), and the Inner Gundeck Bulwark Pattern – Front Right (215).

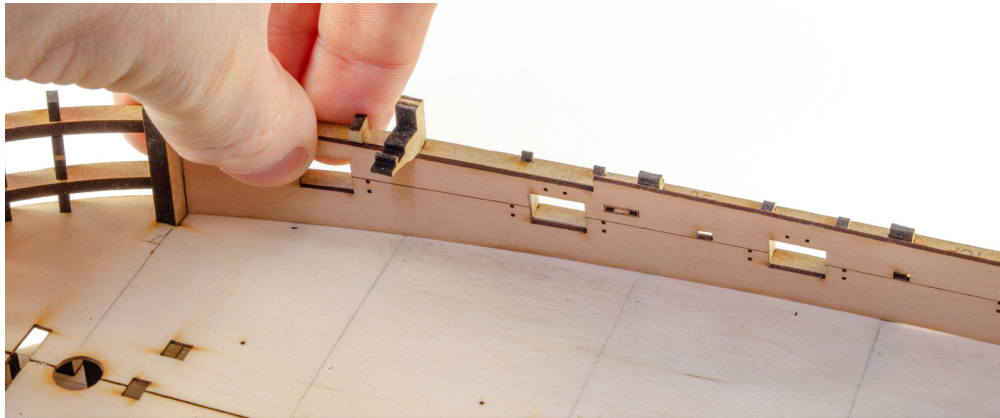

89. Take part 215 and test fit along the inner bulwark frame. The gunports will align along the length, and the holes are a little smaller than needed so you can trim them to the correct size later. No soaking is needed to fit any of these parts. Also, don't worry about any slight gaps you might have in places between the bulwark and ply deck. The laser deck and spirketting will hide those.



91. From the 2mm wood sheet, remove parts the Quarterdeck Beam Spacing Pattern – Right (409) and the Quarterdeck Beam Spacing Pattern – Left (410).

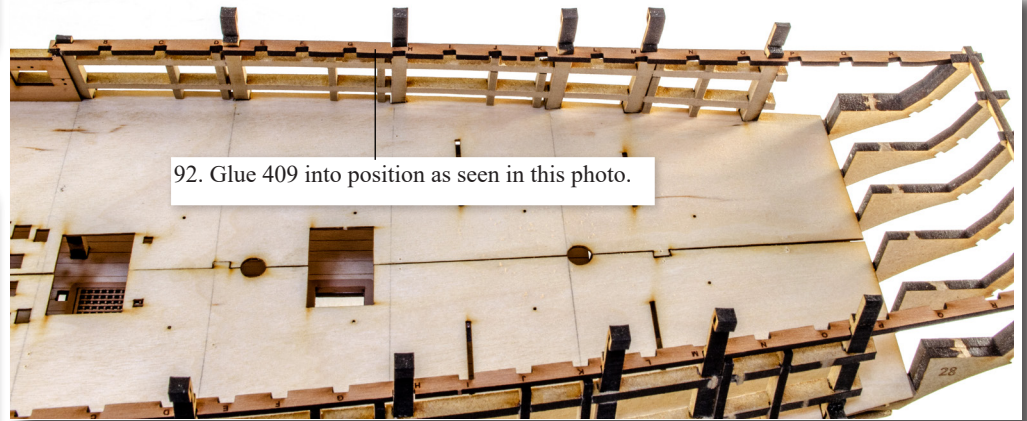

92. Glue 409 into position as seen in this photo.

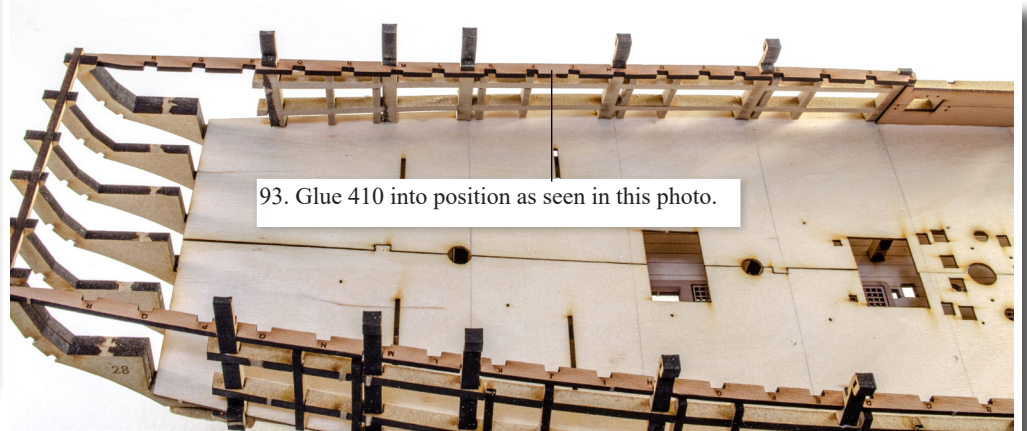

93. Glue 410 into position as seen in this photo.



90. Once you have the bulwark properly aligned for the very best fit, add clamps to hold it in position. You can now paint in diluted wood glue from the reverse framework. Leave to dry. Repeat the process for the front left bulwark (213).



94. This photo shows how the rear of 409 and 410 slot into the timbers at the top of the stern.



95. From the 1mm wood sheet, remove the Inner Bulwark Gundeck Pattern – Rear Left (214) and the Inner Bulwark Gundeck Pattern – Rear Right (216).



96. You will need to test fit these parts before gluing as some minor adjustment may be needed at the rear of the part, so it sits as shown here. This is part 216. We have left a little extra length here to allow for variation. Once you have the best fit, clamp and then paint in dilute wood glue from the reverse. Repeat with the opposite bulwark, 214.



97. All inner bulwarks are now fitted.

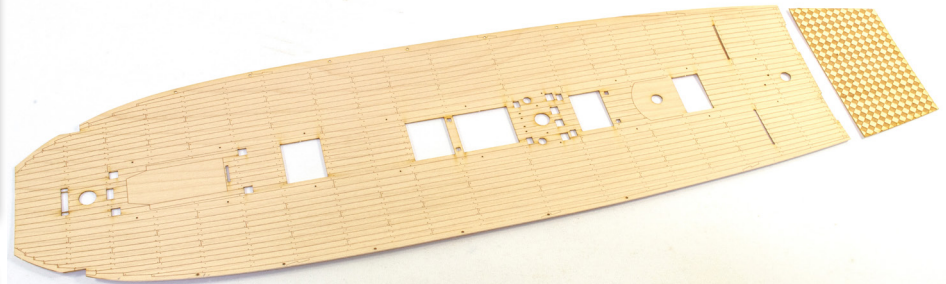

98. From the laser engraved 0.8mm veneer sheet, remove the Gundeck Pattern (53) and the Aft Gundeck Chequer Pattern (54).

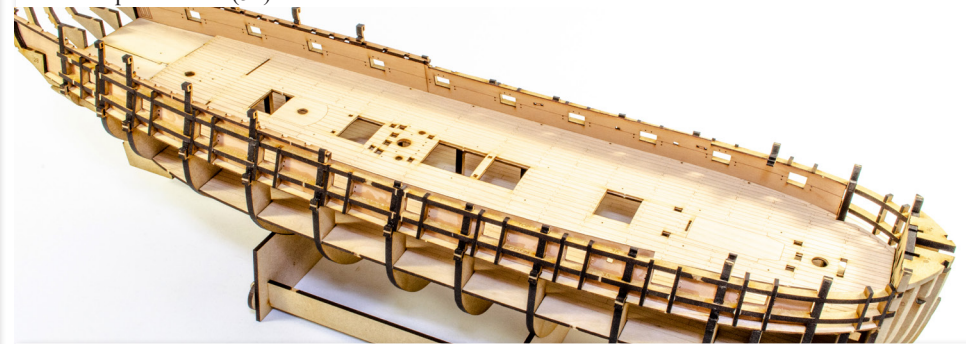

99. Test fit (NO NOT GLUE!) the Gun Deck Pattern and the Chequer Pattern. You may need to carefully sand the deck edges, so the deck aligns properly and sits down all the way around the edges. Also check that the deck lies flat in the middle. When happy with the fit, remove the laser deck parts.

100. From the 0.6mm wood sheet, remove the Forward Gundeck Cabin Bulkhead – Front (59). Sit this into position in the forward gundeck slots as shown and use a pencil to mark the rear of the bulkhead onto the bulwark. The bulkhead must be vertical for this. Remove the bulkhead part and store safely until later. This is the area up to which you will apply the red paint.

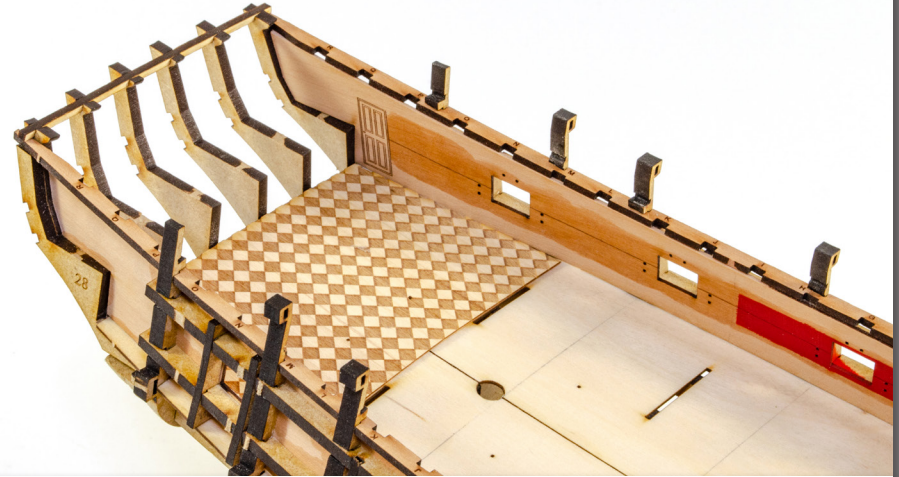

102. The Chequer Pattern deck section (54) is now glued into place, immediately to the rear of the rearmost deck slots.

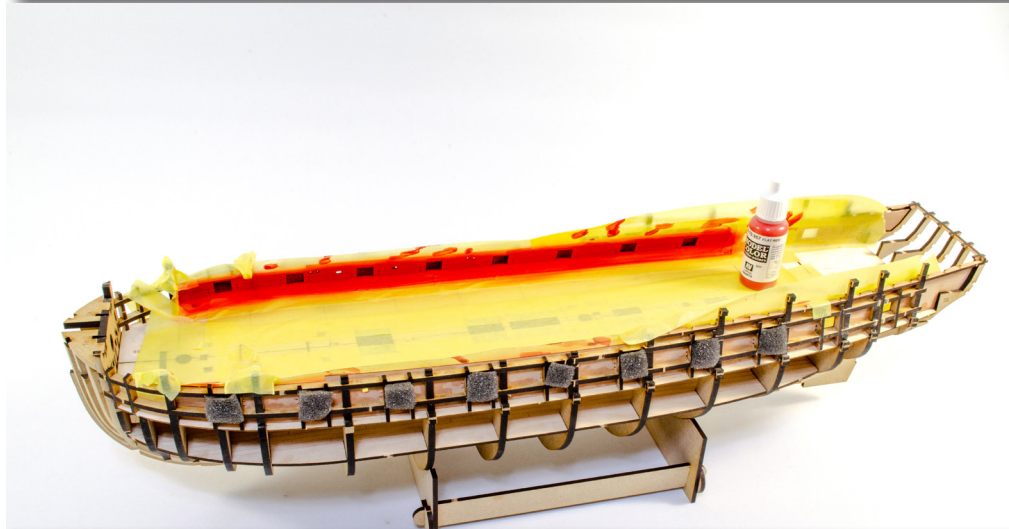

101. You can of course leave your inside bulwarks in bare timber and varnish them, but we have decided to paint them in the traditional red that was common for the time. Before painting, dilute polyurethane varnish was painted between the gun ports and a few millimetres above and below them. This creates a good surface to paint on. The model is then masked off so only those areas are painted. An initial coat of Tamiya Flat Red was airbrushed over the bulwarks, followed by a couple of very light coats of Vallejo.

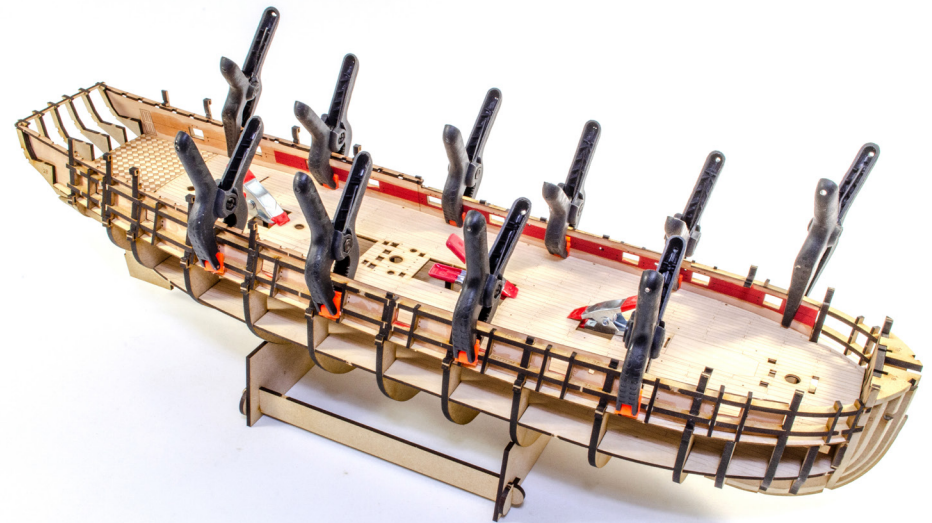

103. Using dilute wood glue, the Gundeck Pattern is now also glued into place. Clamps hold this down around the edges and small clamps help in the middle, around the various openings.



104. From the 0.6mm wood sheet remove the Lower Spircketting, parts 106, 107, 108, and 109. Note the sheet has the direction etched on for these parts (FRONT, REAR). Write these on the back side of these parts so you don't mix them up, although the longer section goes to the front of the ship.



105. From the 0.6mm wood sheet, remove Deck Clamp Pattern – Front (110), and the Deck Clamp Pattern – Rear (111). There are two sets of these you need to remove.



106. Dry fit the lower spircketting to the bottom edge of the inner bulwark so it's up against the floor and with both parts in place, mark the same line on the rear part for the painting demarcation line. Do this for both sides. Paint the spircketting in red as per bulwarks (except for cabin area).



107. Glue the Gundeck Lower Spircketting – Front Right (108) into place as shown and use clamps until set.

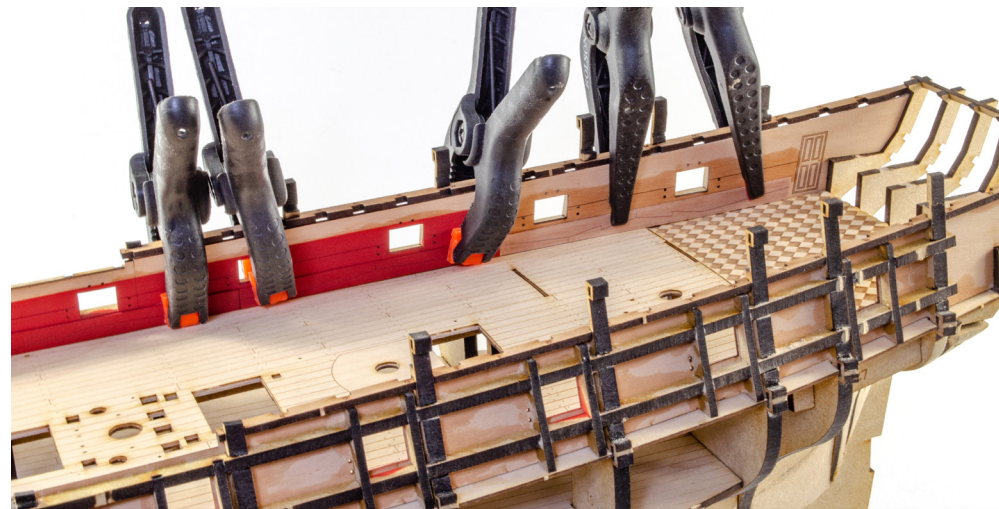

108. Now glue the Gundeck Lower Spircketting – Rear Right (109) into position as shown. You may need to trim the back edge, so it stops about 2mm from the engraved door. Once dry, fit the spircketting on the opposite side of the deck.



109. Paint the Deck Clamp Patterns in the same way as the bulwarks, so the rear cabin area is left in bare wood.



110. Glue the Deck Clamp Pattern – Front (110) into position as shown. NOTE: Leave the top edge of this slightly higher than the adjacent bulwark.



111. Now glue the Deck Clamp Pattern – Rear (111) into position as shown, again leaving the upper edge slightly higher than adjacent bulwark. The top edge of this will fall more or less directly under the quarterdeck beams that sit over the rear bulwarks.

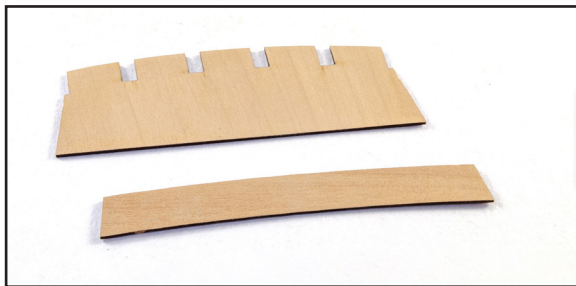

112. From the 1mm wood sheet remove the Stern Cabin Bulkhead Pattern (197) and the Stern Cabin Seat Pattern (198).



113. Glue the Stern Cabin Bulkhead Pattern into place as shown. You may need to slightly adjust the curve to the deck with sandpaper.



114. Now glue the Stern Cabin Seat Pattern (198) into position. You may need to trim this slightly to fit your model exactly, and we have allowed for these variations.

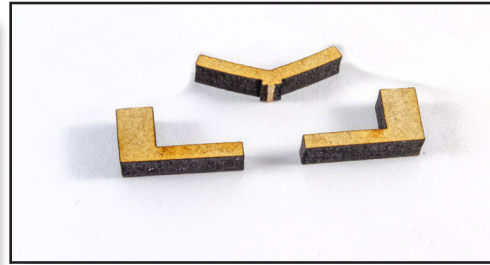

115. From the 4mm MDF sheet, remove the Forecastle Bulwark Patterns 16, 17, and 18.



116. Glue parts #16 into position as shown into the slot on the edges of parts 18.

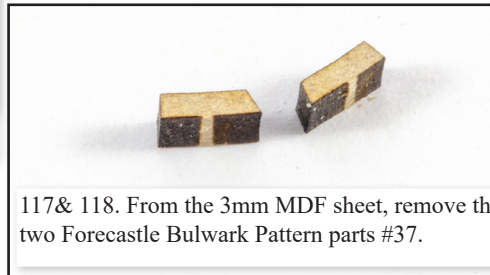

117& 118. From the 3mm MDF sheet, remove the two Forecastle Bulwark Pattern parts #37.

Please ignore these parts - They are not required



119. Glue parts #37 into position as seen here.

Please ignore these parts - They are not required

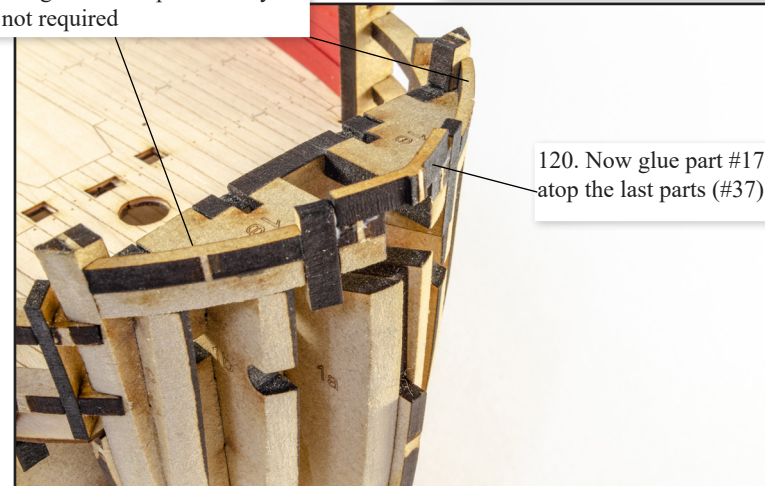

120. Now glue part #17 into position atop the last parts (#37).

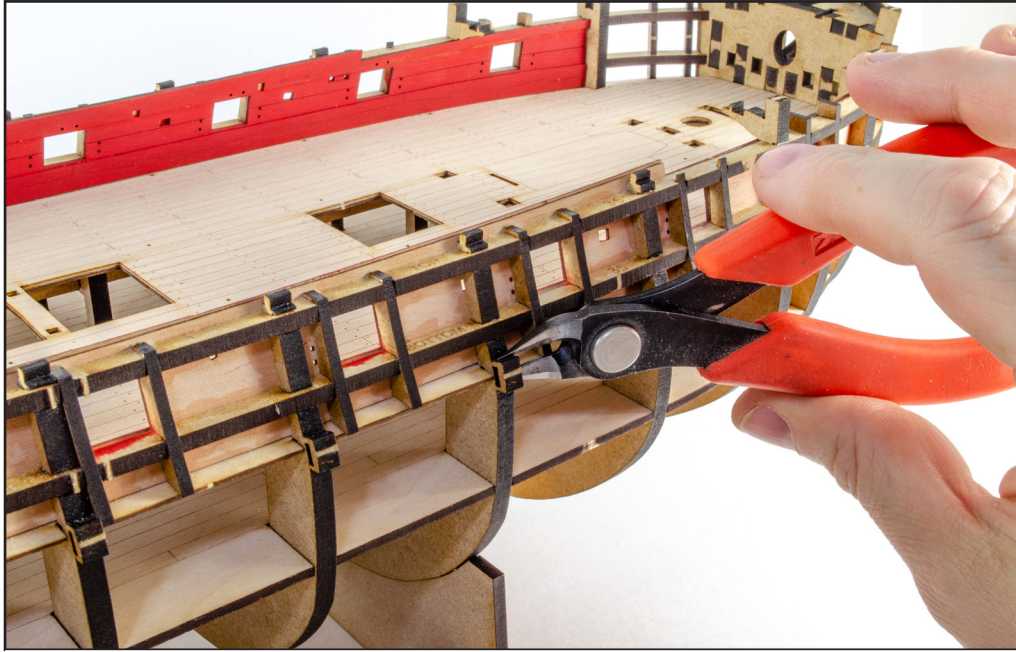

121. As the basic hull structures are now complete, we need to fair the hull in preparation for planking. Before we can do this, the 'safety gates' must be snipped from each of the bulkheads along the gun deck height, as seen here. The hull is now very strong and no longer needs these features.

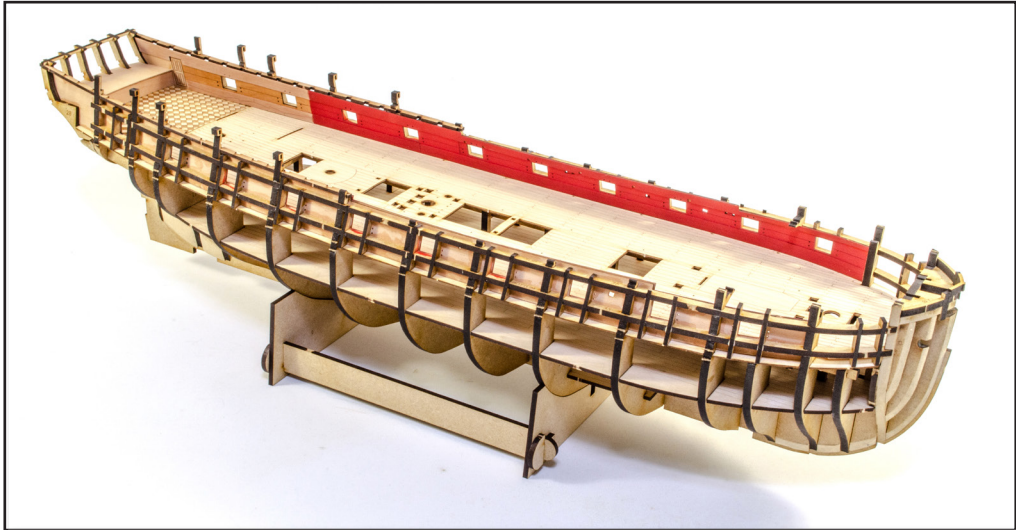

122. Your HMS Sphinx should now look like this. It'll be soon time to create some dust, so get your mask ready!



123. Before any external faces/planks are added, you'll need to get to grip with some jigs. These are designed to maintain the width between bulwarks whilst adding those external areas. From the 3mm MDF sheet, remove parts J-U, J-V, J-X, J-Y, and J-Z. Also remove parts #30. 'J' means that the parts are jigs, and these should NOT be glued to the model.



124. You can assemble and glue the jig using the parts you just removed though. Each slot in #30 is labelled for the appropriate jig part.



125. When fitted (**NO GLUE!**), the jig looks like this. Please fit and remove it when you feel appropriate, depending on ease of working on model.



126. From the 4mm MDF sheet, remove parts J-4, J-5, J-6, and J-7. The clip across the top of each bulkhead with the same number (i.e., J-7 across bulkhead #7). **Again, do NOT glue these.**



127. Lastly, from the 2mm MDF sheet, remove parts J-9, J-10, J-11, and J-12. To fit these to the appropriate bulkheads, you'll need the small keys J-0 on the 0.8mm ply sheet. As with the other jig parts, you'll find J-9 will fit to bulkhead #9 etc. **Please don't glue these to the model either.**

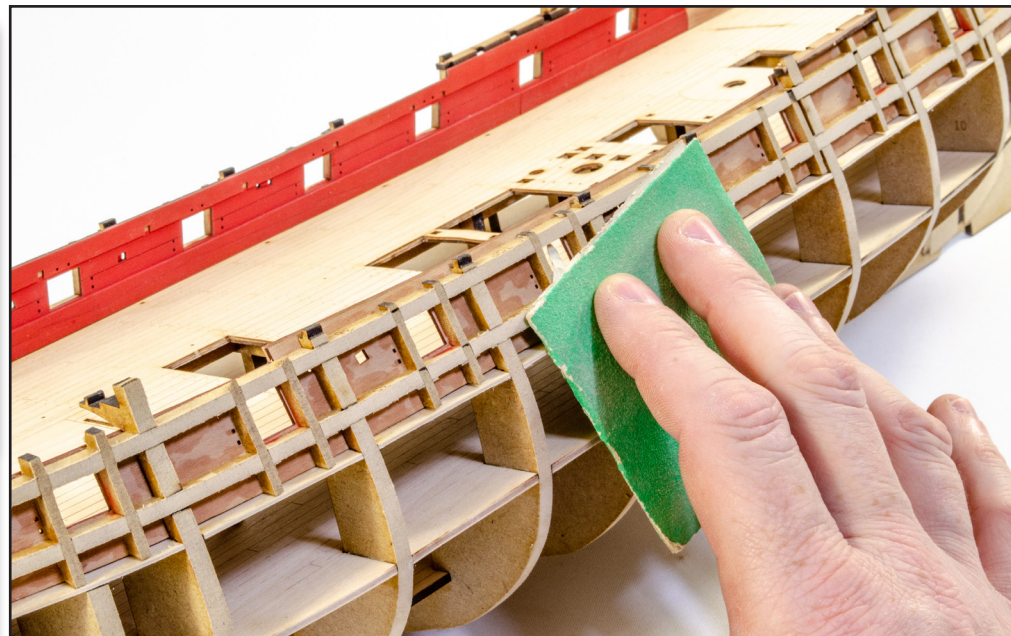

128. Before adding any jigs, it's time to fair the hull in readiness for planking etc. Most of the hard work is already done at the bow and stern, and they will only need a little extra sanding. Sand the hull so the lines flow properly and use a plank to lie against it at various points to ensure maximum bulkhead contact.

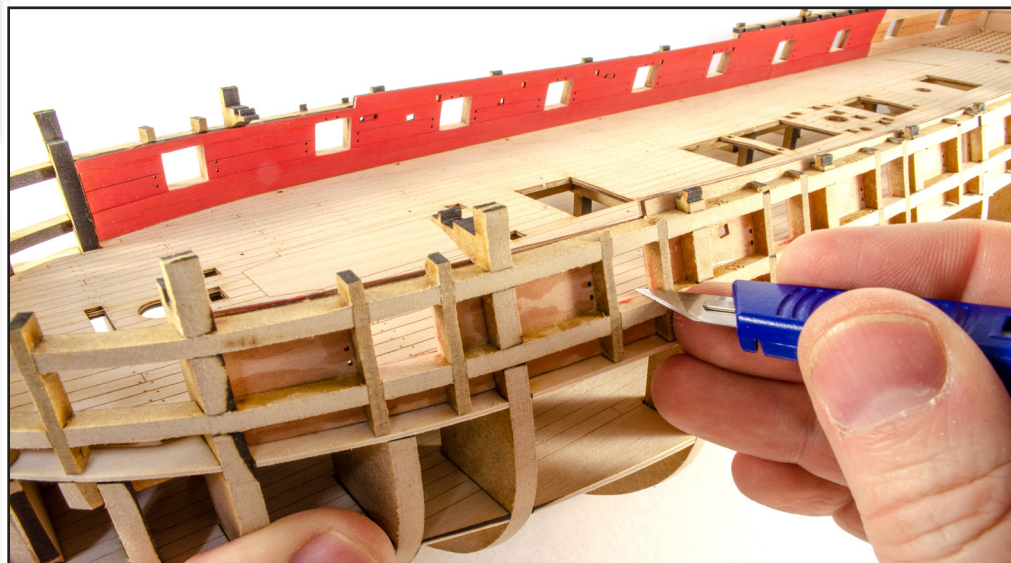

129. You can now trim the gunport openings on the inner bulwarks, so they are the same size as the MDF framing.

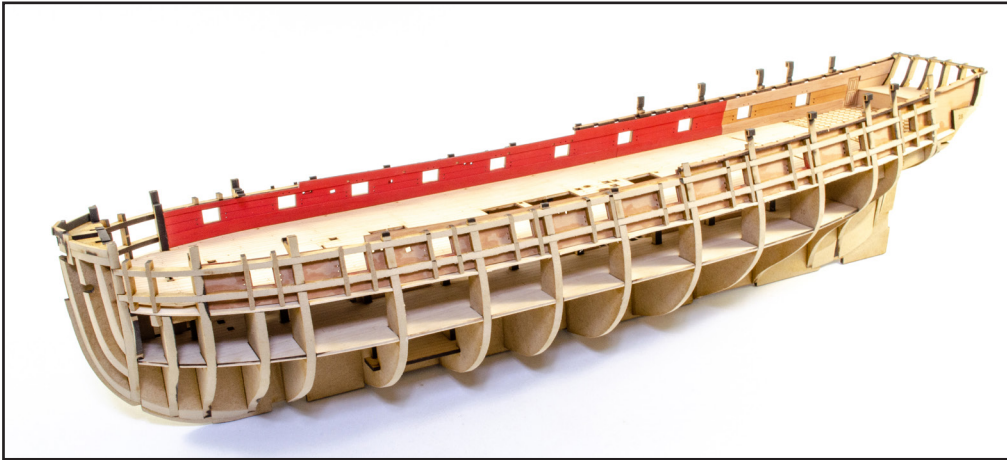

130. Stand back and admire your work again for a few moments as it's now time to add some timber to the exterior.

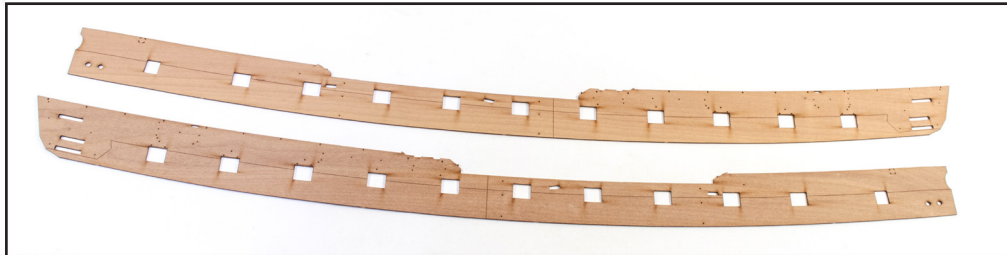

131. For the first layer, remove the Upper Hull Side Pattern – Left (136) and the Upper Hull Side Pattern – Right (138), from the 0.8mm ply sheet. Note that the engraved sides will face outwards.

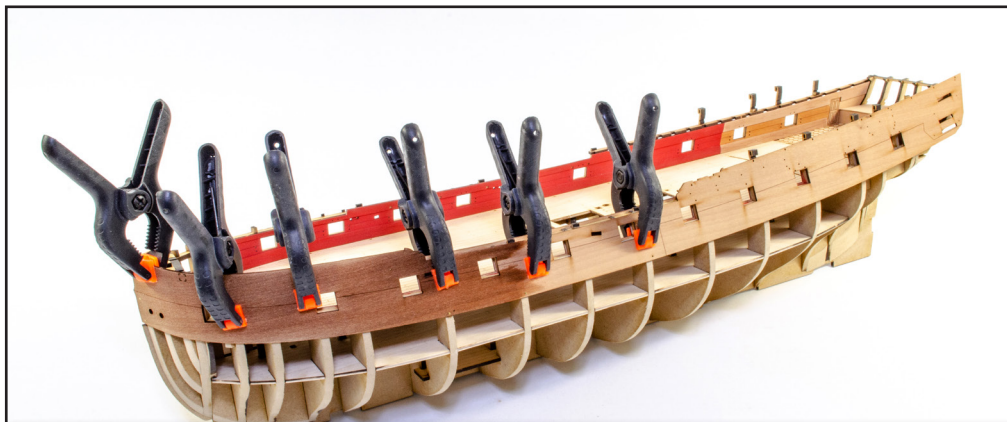

132. Soak the forward half of each part in hot water for about 45 minutes and lie them in turn in position on the hull, clamping until dry. We suggest you leave these parts about 12hrs to thoroughly dry before use.



133. You will note that if you faired the hull properly, these parts will lie flat against all bulkheads, with no ripple or gaps. If you do find gaps, you'll have some time to correct this before we finally fit these parts.

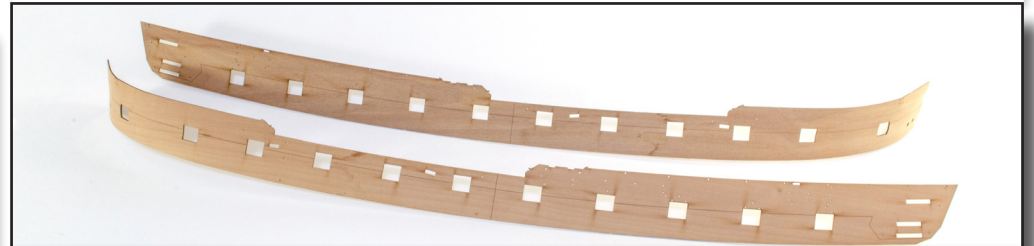

134. When removed from the hull, both parts will retain their curve and be easy to finally fit.

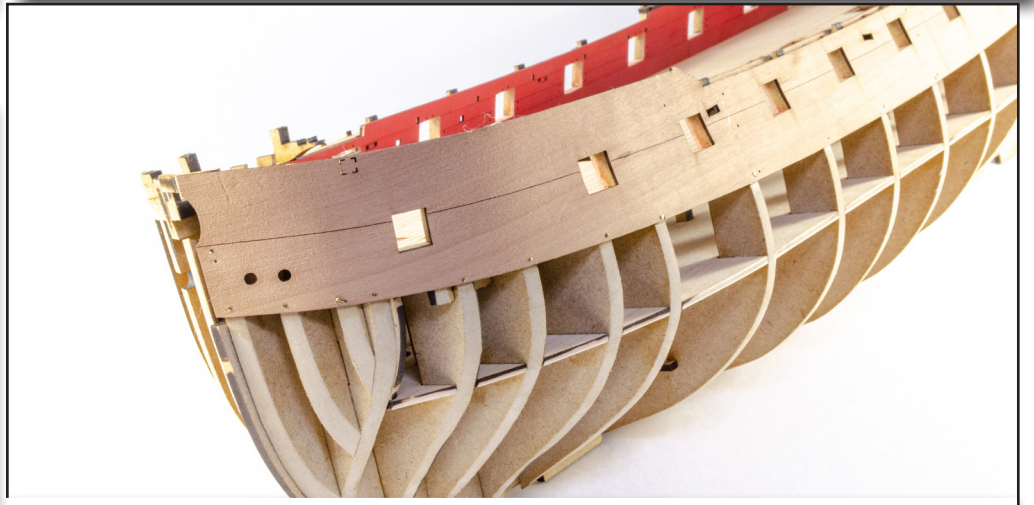

135. Glue each Upper Hull Side Pattern into position as shown. You can also use pins to tack the bottom edge of the parts onto the bulkheads. TIP: Use dilute wood glue to fit the patterns as this will give you more time to adjust things before the glue starts to set.

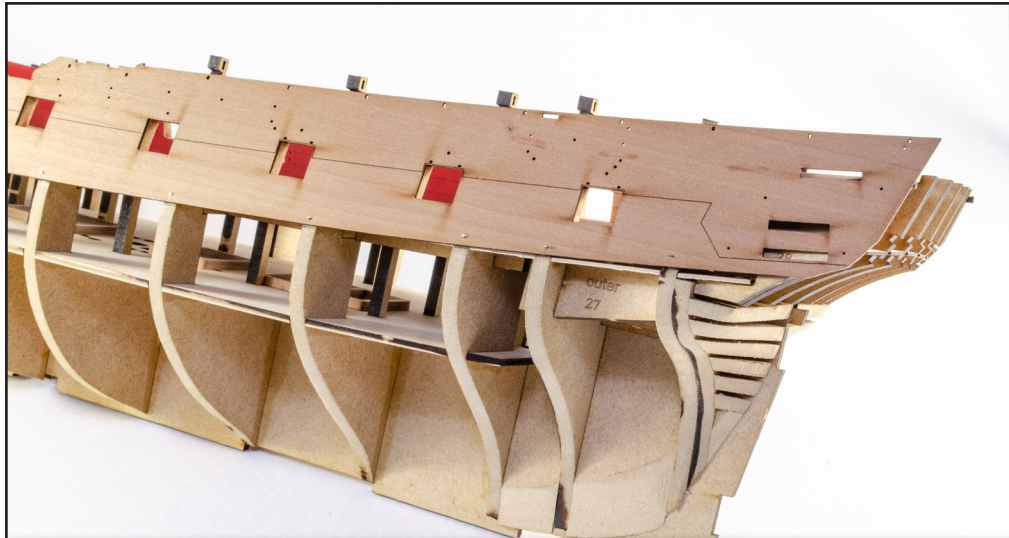

136. Properly aligned, the gunports will line up with the frame. There is a little extra around the ports but try to get these patterns as close as possible.

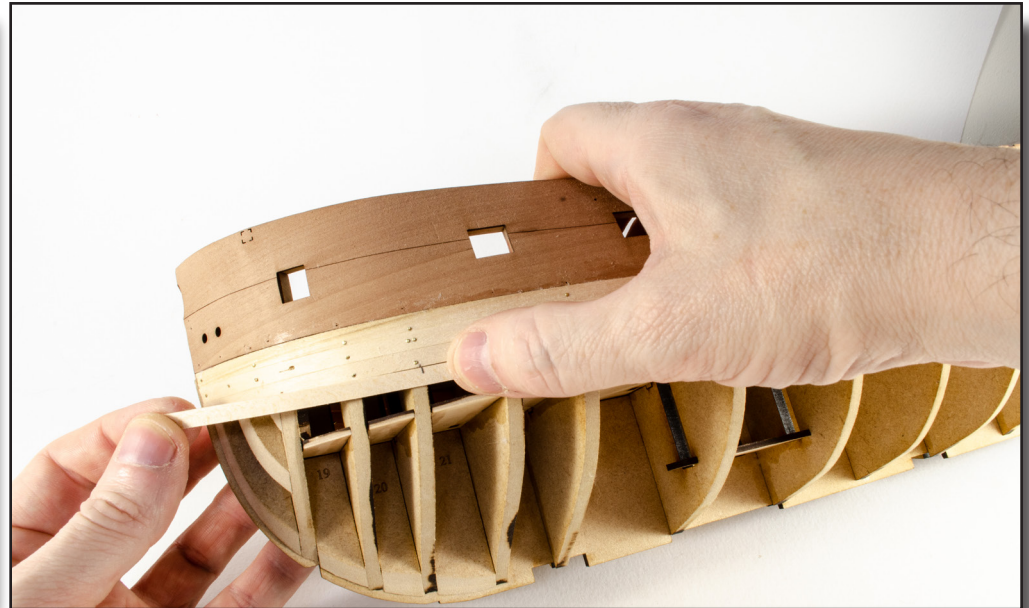

138. The hull is now to be planked using the 1mm x 5mm x 700mm limewood strips (F-36). On the prototype, the first three strips were added without tapering. After this, where the following plank tries to naturally cross over the previous, make a pencil mark.



137. Once fitted, leave the parts to dry for a few hours. Notice the jigs are temporary fitted to maintain the width of the hull.

It is very important to use the jigs as much as possible to maintain the correct width for the upper decks throughout the whole hull building and planking process.



139. Now make another pencil mark about $\frac{1}{3}$ to $\frac{1}{2}$ down front end of strip and cut between the two marks, seen here in pencil. NOTE: on my prototype, I didn't find a need to taper the stern end of the plank, only the bow.



140. You will find that you get a better plank to plank fit if you slightly bevel the edges between some planks. Remember, this is only a first layer, so the finish doesn't need to be perfect. You may also find our Plank Bender tool useful for forming curves such as those around the stern, as you won't need to soak any planks.



141. The lines of HMS Sphinx mean that she is quite easy to plank and shouldn't really present any problems. I used a 'Pin Pusher' tool to assist me when planking, and we recommend wood glue (PVA/white glue) as your adhesive.

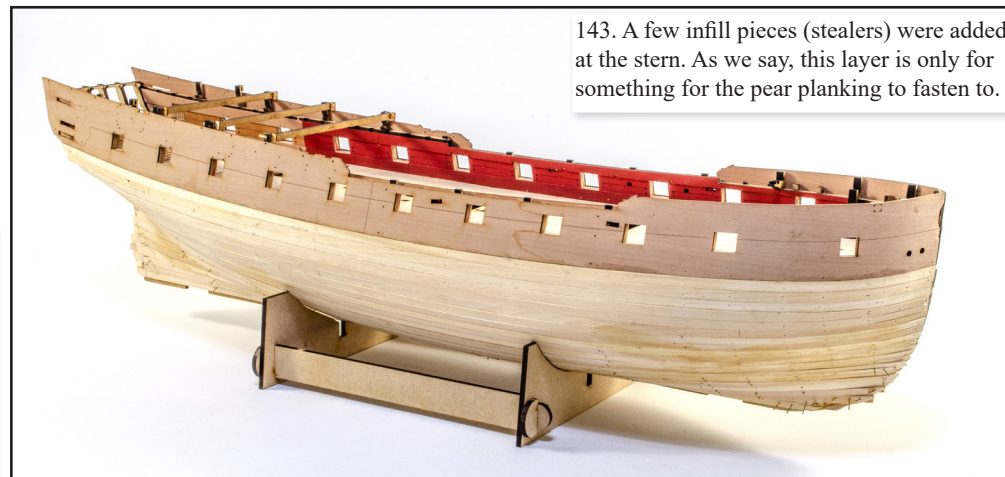

143. A few infill pieces (stealers) were added at the stern. As we say, this layer is only for something for the pear planking to fasten to.

144. Sand the hull smooth. We suggest using something like 110 grade paper. Make sure there's no bumps and the transition between the ply side patterns and planks is also smooth. Remember to sand the planks in the deadwood area so they taper to 0mm towards the stern post area.



142. You will note the tapered bow planks and also untapered at the stern, but you are of course free to plank your model in any way you normally would.



145. Remove the Lower Counter Pattern – Inner (155) from the 1mm wood sheet.

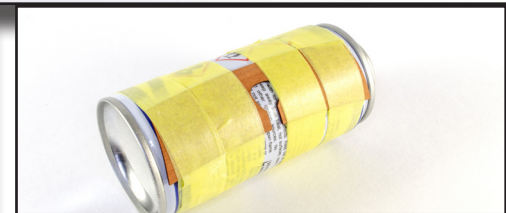

146. Whilst you could attempt to fit this and simply pin it in place, we do suggest you curve it slightly first. To do this, soak for the part in hot water for 30 minutes, then tape around a curved surface such as a can or jar. Leave the part overnight to dry out.



147. The counter will now look like this. The pencil lines are where I have marked the positions of the stern timbers it will sit on. I have also drilled some 0.5mm holes to make this easier to pin to the MDF underneath.



148. Before fitting the lower counter pattern, you can trim the ends of the ply bulwarks, so they are flush with the end stern timbers. Lightly sand the stern, remembering that this area is curved.

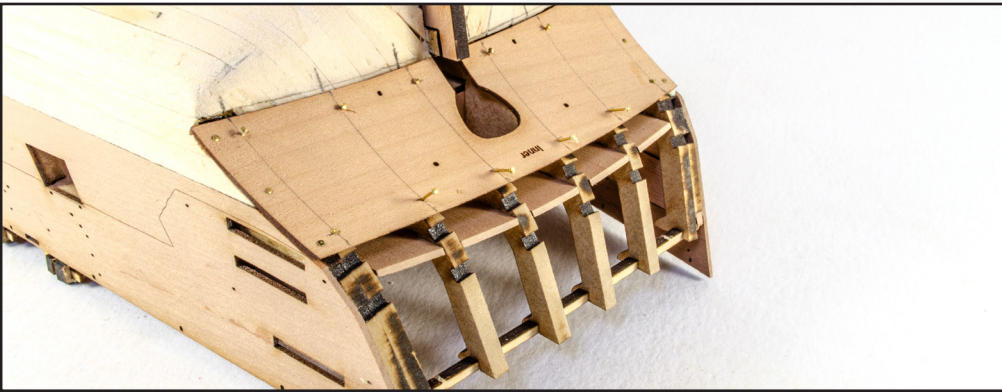

149. The lower stern counter is now glued and pinned into position. To help with the position of this, the rudder post (447) is temporarily clamped into position. **IMPORTANT NOTE:** Please slightly reposition the stern counter so it is slightly higher on the stern and the top edge falls at the same height as the bottom of the stern timber slots. This will elevate the stern fascia and transom by around 2mm from the position shown here.

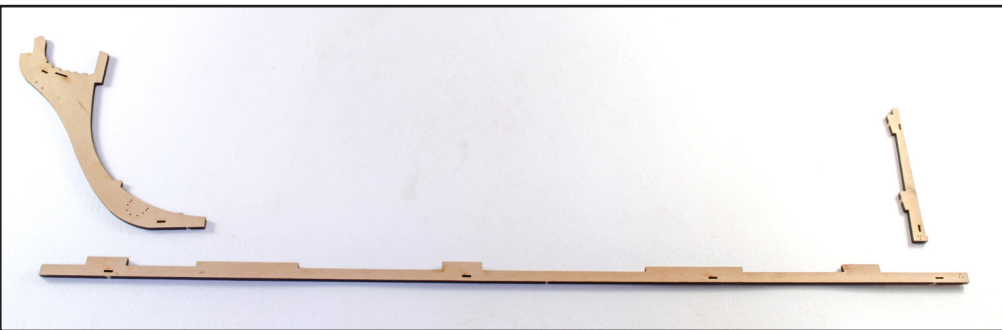

150. From the 3mm wood sheet, remove the Prow Pattern (445), Keel Pattern (446), and Rudder Post Pattern (447). You may have already removed the rudder post pattern to help in the previous stage.



151. Using wood glue, glue the Keel Pattern into place on the underside of the hull. This can only fit one way around due to the tabs. Leave to set.

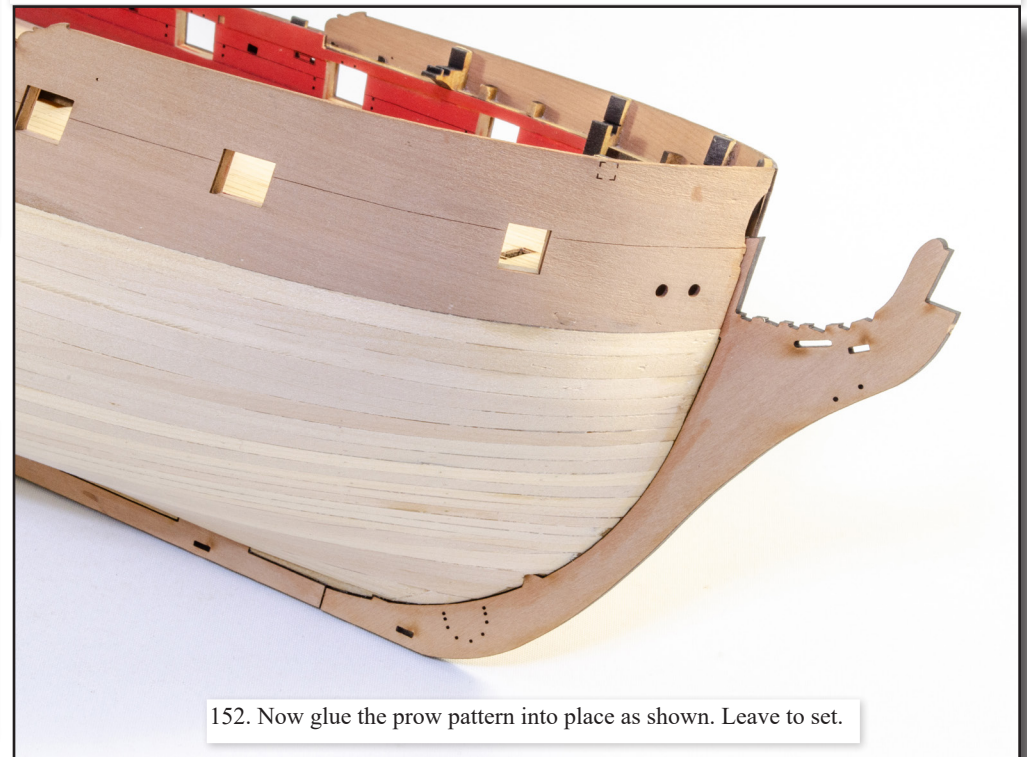

152. Now glue the prow pattern into place as shown. Leave to set.



153. Lastly, glue the rudder post pattern into place as shown. Leave to set.

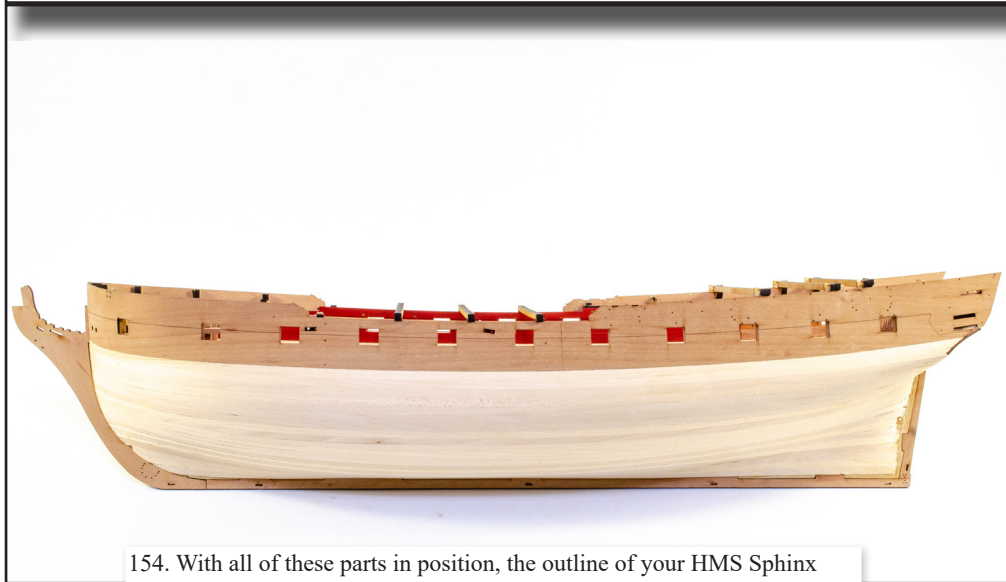

154. With all of these parts in position, the outline of your HMS Sphinx will now have changed significantly.

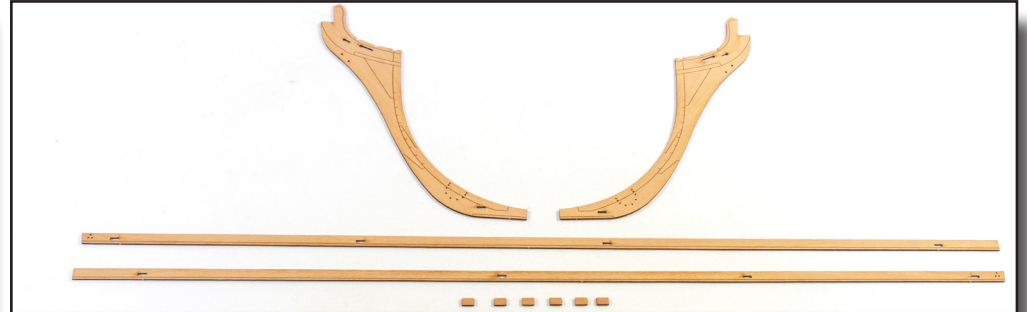

155. From the 1mm wood sheet, remove the two Prow Outer Patterns (190, 191), and the two Keel Outer Patterns (192, 193). Also remove six of the Location Pegs (187) from the same sheet.

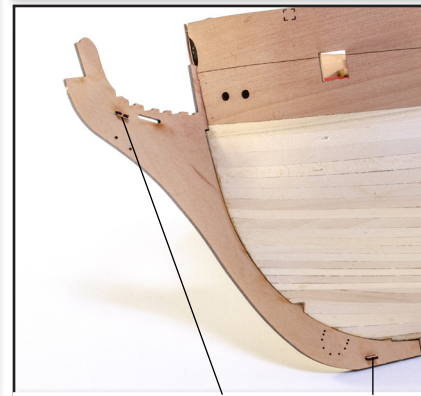

156. At the prow, plug two of the location pegs into position in the narrow slots, as shown here.



157. The prow outer patterns can now be glued into position, with the pegs helping with alignment. TIP: apply glue to the prow instead of the thin pattern. This will prevent the pattern from curling while you align it. Use clamps to secure in position until set. Do this for both sides.

158. Now apply the location pegs to the keel and glue the keel outer patterns into position. Use plenty of clamps to hold the pattern flat whilst the glue dries.





159. From the 1mm wood sheet, remove the two Rudder Post Outer Patterns (188, 189), and also the Rudder Post End Pattern (196)



160. Using two more location pegs which are first slotted into the rudder post, glue the rudder post outer patterns into position. You will notice these will only fit one way. Clamp until dry.



161. Now glue the rudder end post pattern into position. Note that the 'T' denotes TOP, whilst the 'B' denotes BOTTOM.

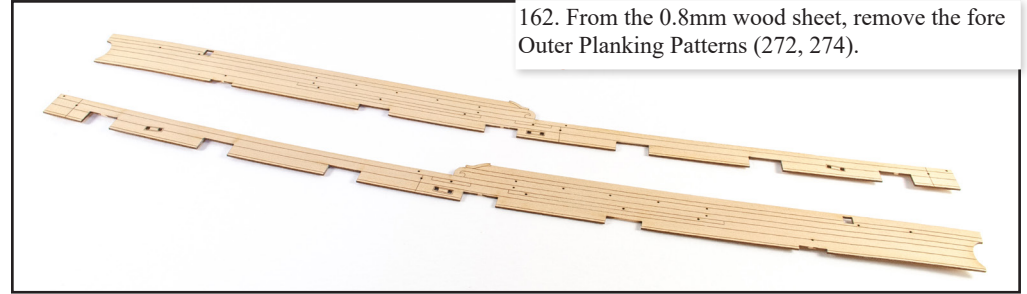

162. From the 0.8mm wood sheet, remove the fore Outer Planking Patterns (272, 274).

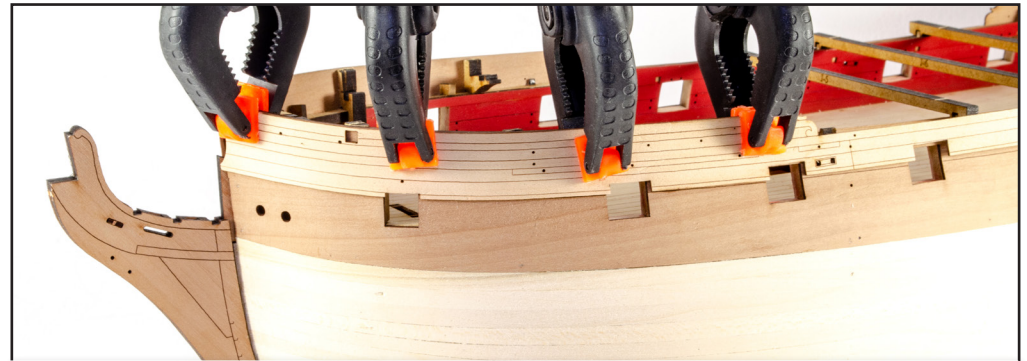

163. Soak these parts for 30 minutes in hot water and then clamp in position on the hull, until completely dry. We suggest leaving this overnight, for a minimum of 12hrs as pear can expand quite a lot when soaked.

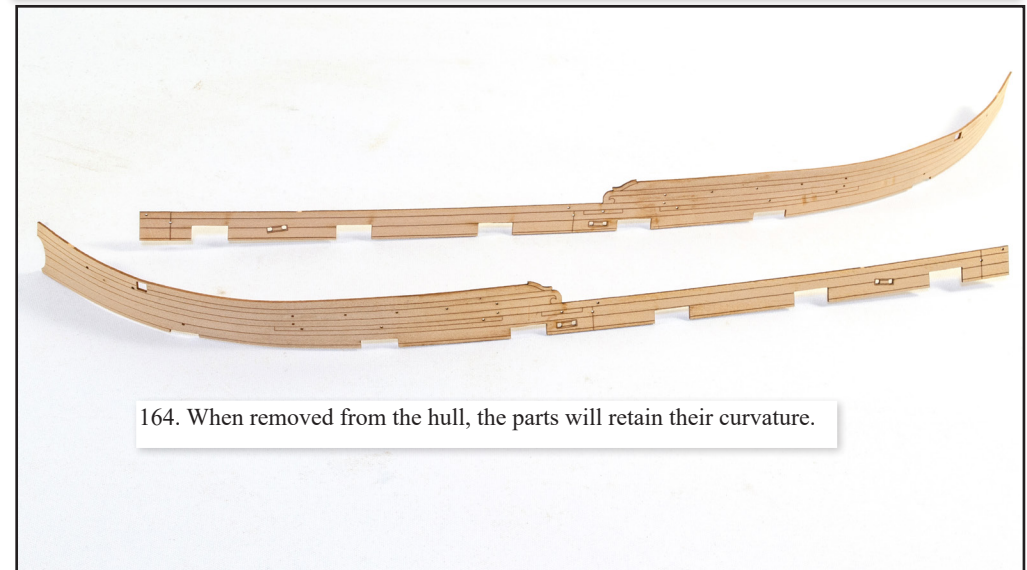

164. When removed from the hull, the parts will retain their curvature.



165. Both patterns can now be glued to the hull. TIP: We suggest using diluted white glue, applied to the hull and not the pattern. If applied to the pattern, you will find it curls, making it harder to fit. You may need to slightly adjust the pattern to fit your model by sanding a little from the front edge. Test fit to ensure best fit first.

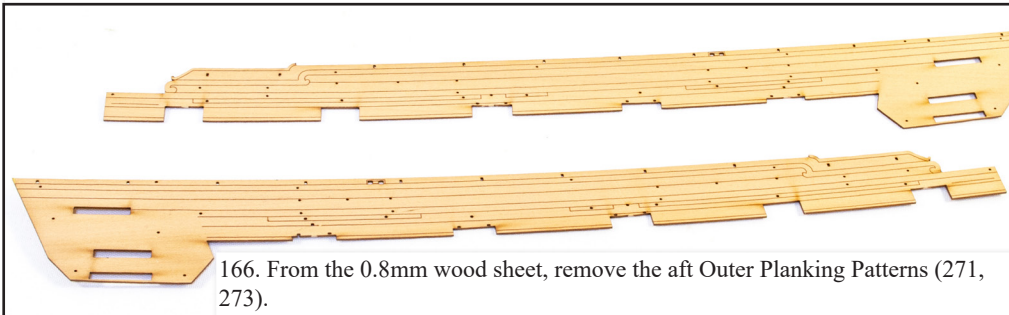

166. From the 0.8mm wood sheet, remove the aft Outer Planking Patterns (271, 273).



167. These can now be glued in position as shown, again applying glue to the hull instead of the patterns, to prevent curling. We also suggest a varied range of clamps so all the edges can be reached.

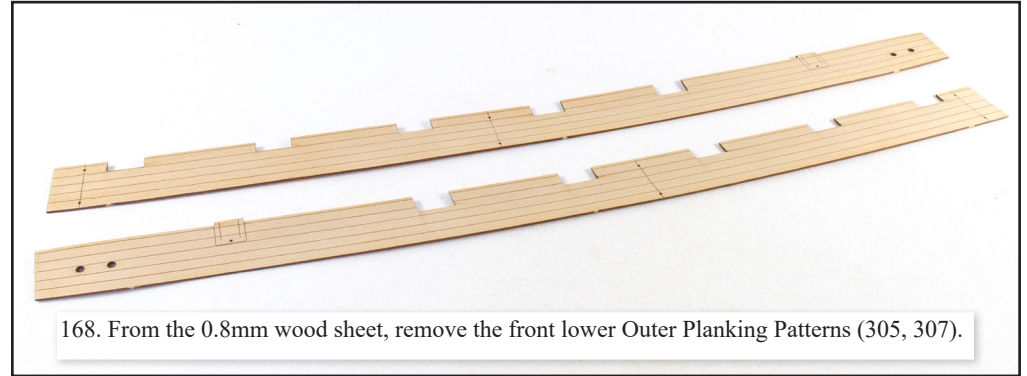

168. From the 0.8mm wood sheet, remove the front lower Outer Planking Patterns (305, 307).

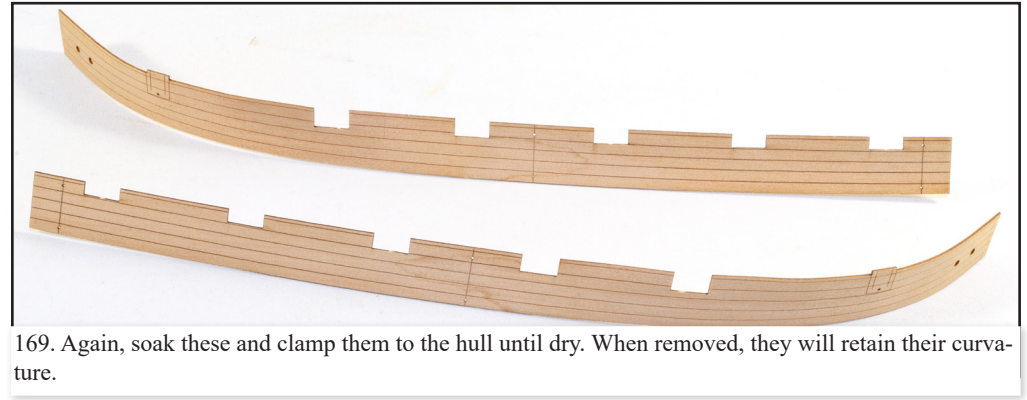

169. Again, soak these and clamp them to the hull until dry. When removed, they will retain their curvature.



170. Both planking patterns can now be finally test fitted, and adjusted (if needed), and glued to the hull. Again, apply your glue to the hull and not the part, to prevent curling. Clamp in position. You can safely use brass pins to hold down the lower edge as this last engraved plank will eventually be covered over. **NOTE: These lower pattern parts are optional. Extra pear planking is supplied in case you wish plank this area traditionally.**

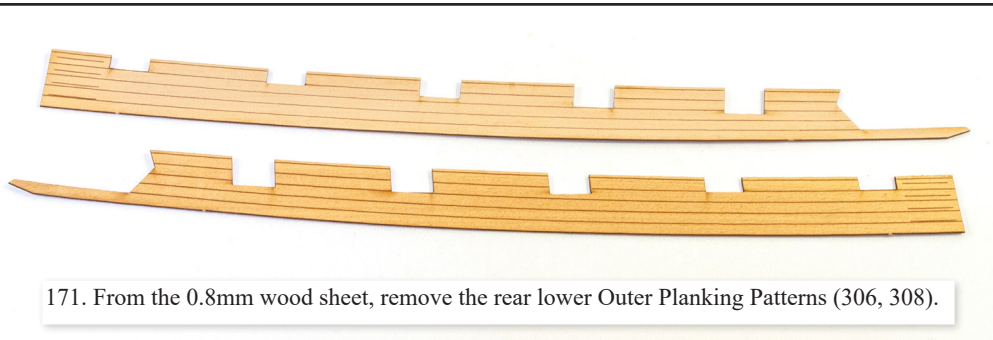

171. From the 0.8mm wood sheet, remove the rear lower Outer Planking Patterns (306, 308).

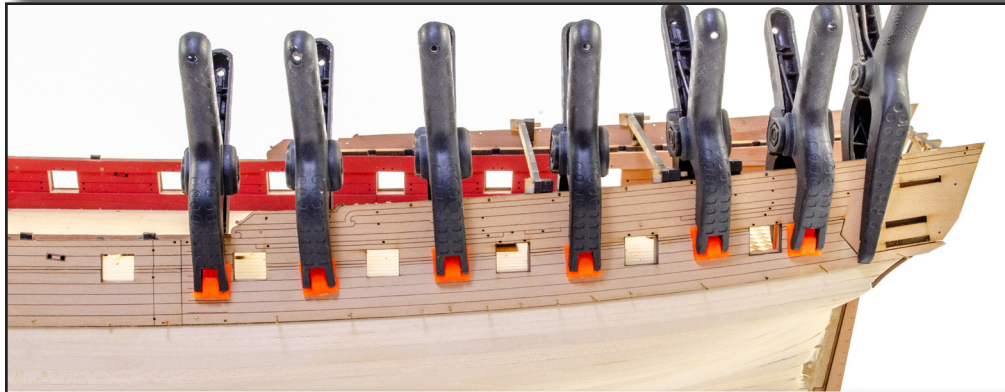

172. These can now be glued into position like the others, with clamps and also pins used along the lower edge to hold things down. **NOTE: These lower pattern parts are optional. Extra pear planking is supplied in case you wish to plank this area traditionally.**

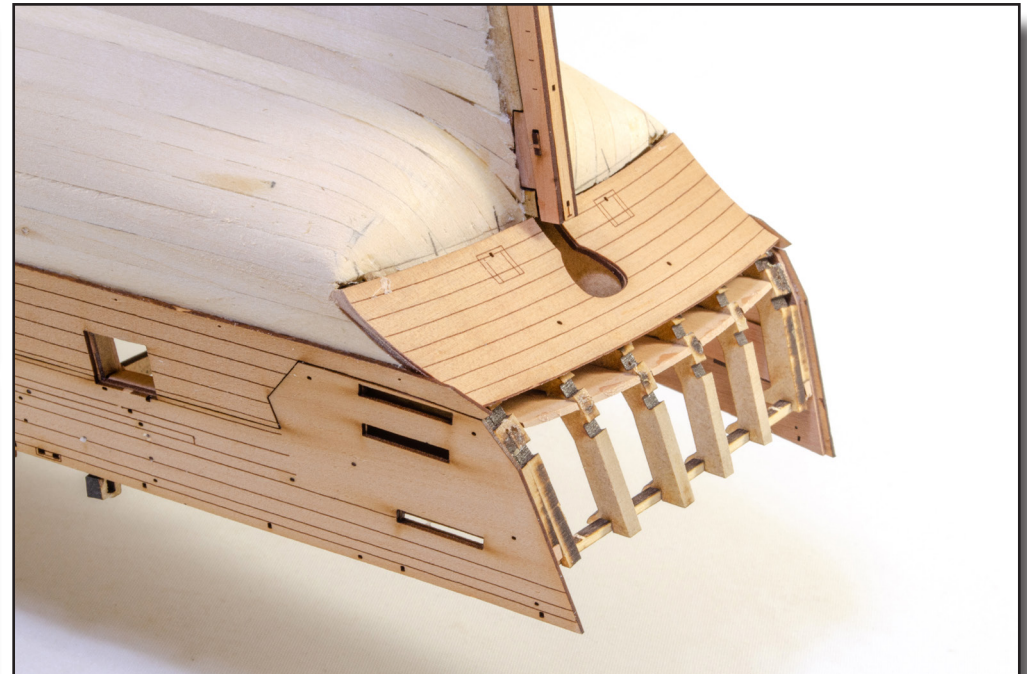

174. Before the hull can be planked, it's time to fit the Stern Lower Counter Pattern – Outer (76) from the 0.6mm wood sheet. You can curve this first if you wish, but we feel this part is thin enough to easily be glued into place over the inner pattern.



173. HMS Sphinx will now look like this.

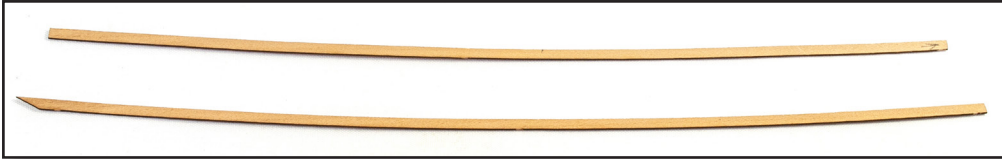

175. The first two layers of planks are pre-cut for you. From the 0.8mm wood sheet, remove the two Plank Pattern – Front Upper (309) and the two Plank Pattern – Rear Upper (310). One of each is seen in this photo.



176. Glue the front upper pattern in place as seen here. You can use whichever glue you choose, but we do recommend CA gel as it no pinning is required, and the parts can be quickly fitted.



177. Now glue the rear upper plank in position. When complete, repeat this process for the other side of the hull.

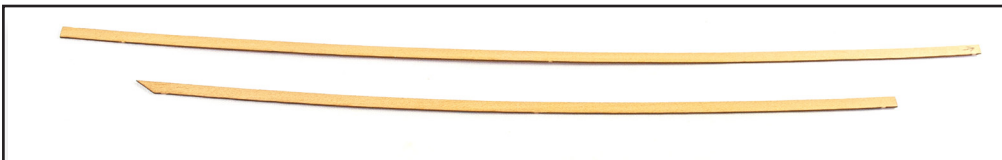

178. From the same 0.8mm wood sheet, remove the two Plank Patterns – Front Lower (311), and the two Plank Patterns – Rear Lower (312).

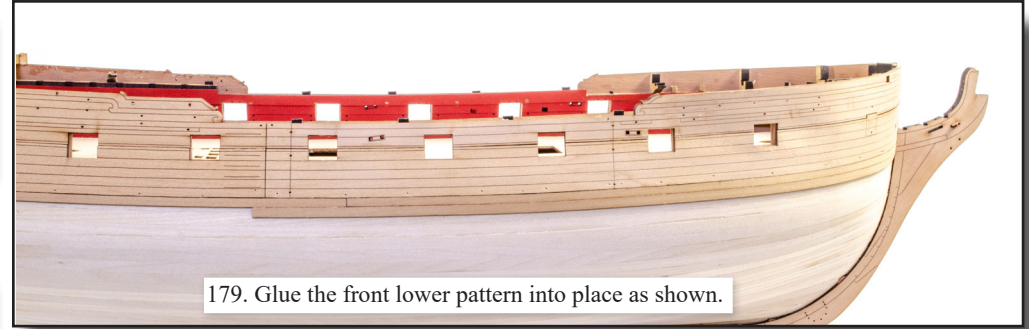

179. Glue the front lower pattern into place as shown.



180. Now glue the rear and repeat the process for the opposite side of the hull. With your hull now looking like this, we can begin to add the second layer of planks to the rest of the hull.

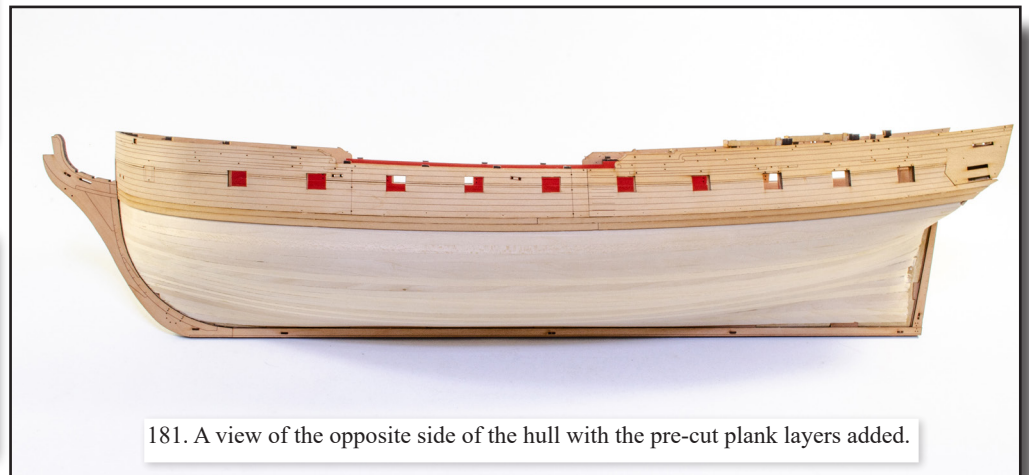

181. A view of the opposite side of the hull with the pre-cut plank layers added.

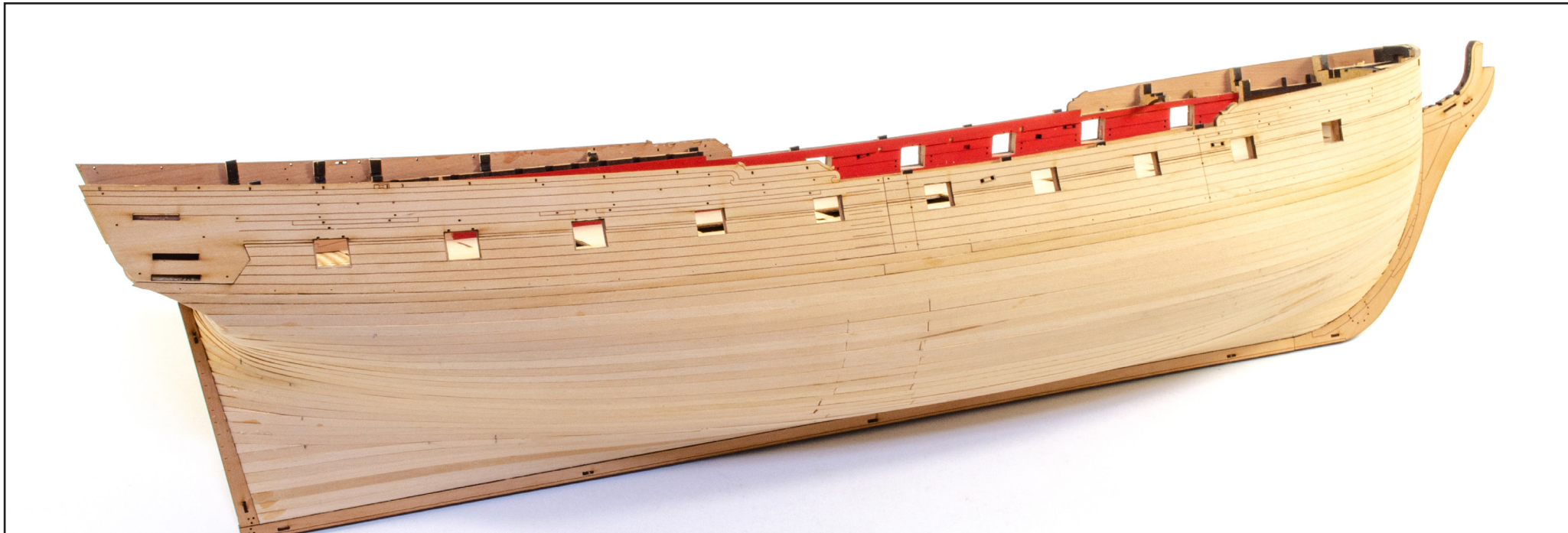

182. Using the 0.8mm x 4mm x 700mm wooden planking (F-37), plank the remainder of the hull as you did with the first layer. Remember that most of this will be hidden under paint. For your information, the prototype had only two full lengths fitted below the previous laser-cut planks, as this area can be seen above the waterline. After this, all planks were fitted as halves as this is easier to get a nice, clean finish to both bow and stern without worrying about the plank length. We also used spots of CA gel to fit the planks and a plank nipper to help with curves around the stern. No planks were pre-soaked, but if you do, let them dry out overnight before fitting them. Remember to taper as you go.

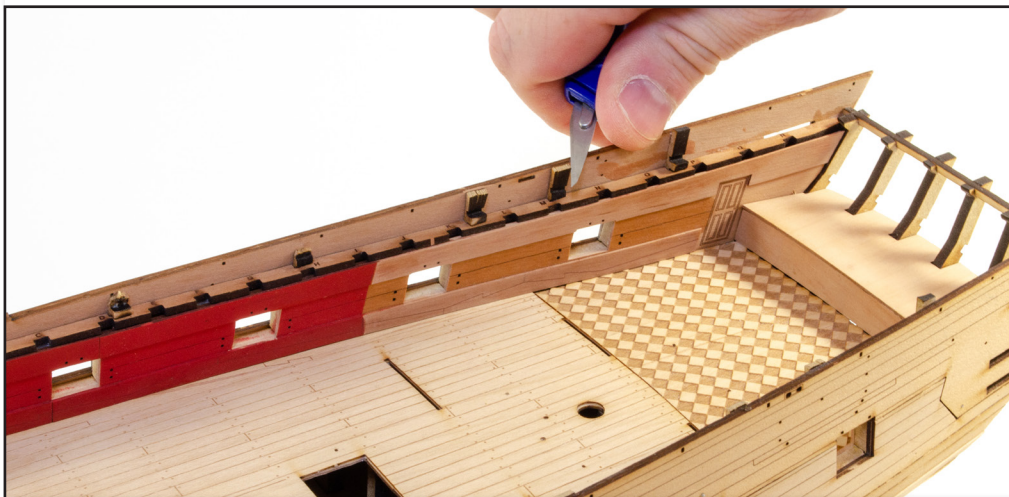

183. All the quarterdeck jigs that you dry-fitted, can now be finally removed. Use a knife to trim down points where the jigs plugged into place.



184. Also remove the nubs where the beams plugged across the open deck area.



185. Before sanding, use masking tape to cover all areas that are laser engraved. The prototype was sanded with 110 grit paper.



186. Check the waterline position both aft and stern (should be exactly the same!) and use a waterline tool to temporarily add a waterline mark. The reason for the waterline mark is so that the area below it can safely be filled prior to painting. We don't want any odd colour filler in the bare wood areas. For filling, we recommend an acrylic filler such as Ronseal's Multi-Purpose Wood Filler (Natural). This is first diluted with water and applied to the hull with a brush. When dry, it's sanded back and the process repeated until no gaps remain. Finish the hull with 320 grit paper, or similar. We won't paint this area just yet.



187. Remove the Main Wale Patterns – Left and Right (137, 139) from the 1mm wood sheet.



188. Take each of the main wale patterns and soak them in hot water for 30 minutes. Lie each one in position on the hull and pin it in place until dry. Due to the expansion of pear when wet, we suggest you leave these parts at least 24hrs before proceeding later gluing to hull.

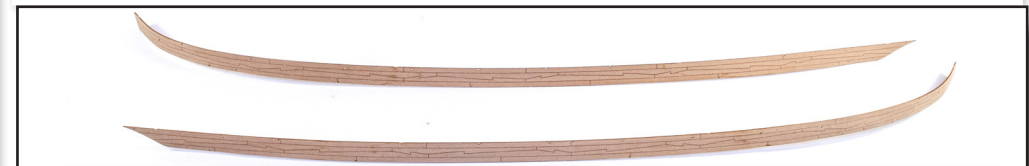

189. When removed from the hull, the wales will retain the curvature from when then dried out.



190. Both wales are now glued to the model. We used PVA for this and pinned where appropriate. There are small nail holes in the wales (NOT the larger scupper holes!), that you can use to pin. Also feel free to pin wherever you feel it necessary.

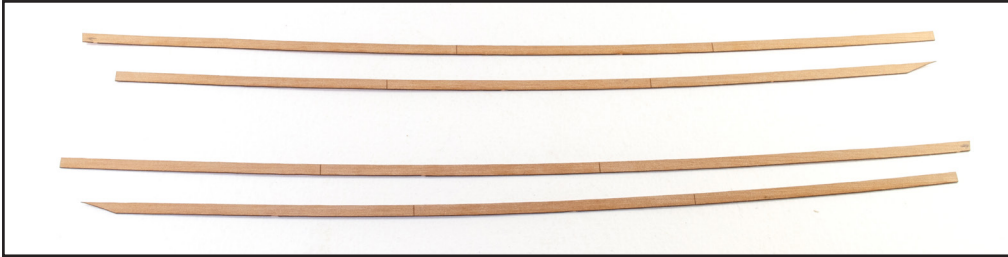

191. From the 0.6mm wood sheet, remove the Strake Above Main Wale – front/rear (71, 72, 73, 74). Of course, the engraved side faces outwards.

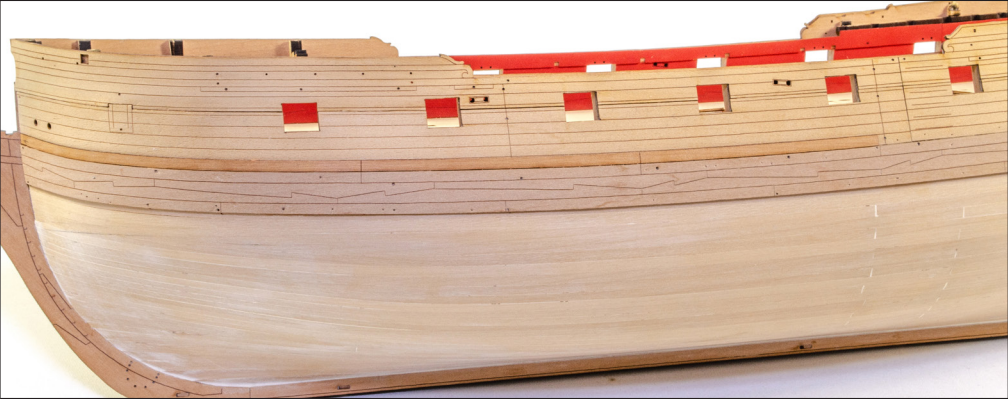

193. Now glue part 72 next to this, along the top of the main wale. When complete, glue parts 73 & 74 on the left side of the hull, in the same manner. Trim down the rear of these parts so they are flush with the stern counter curve.



194. Remove the Upper Counter – Inner (156) from the 1mm wood sheet.



195. Glue the upper counter in position directly above the stern counter. Take some measurements of the hull and part to make sure it's placed centrally. The overhang at either side should be identical. Use pins to hold until dry.

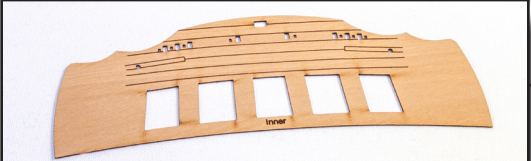

196. From the 0.6mm wood sheet, remove the Stern Fascia – Inner (88).



197. Glue and pin the stern fascia in position. This will curve, following the timber shapes and sit up against the outer sides of the hull.

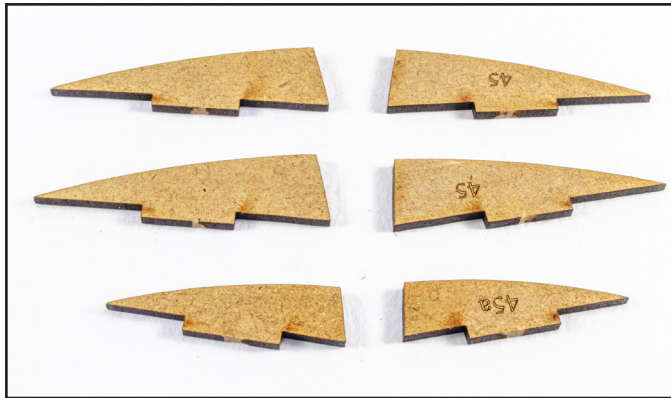

198. Remove the four Quarter Gallery Patterns (45) and the two parts of the same name (45a) from the 2mm MDF sheet.

199. Bevel the back edge of parts 45, so it matches the slope of the stern fascia when fitted into its slot. You may need to shorten the length of parts 45 until the tab sits comfortably in the slot whilst sitting against the stern fascia.

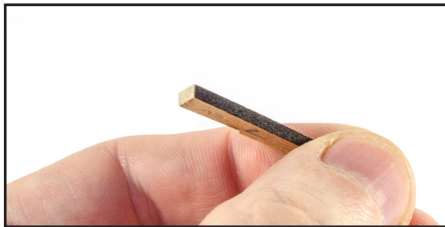

200. Bevel the upper outer edge of parts 45.

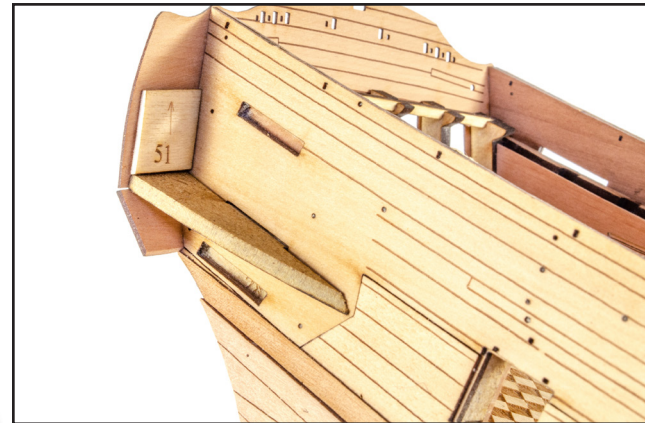

201. Glue one part 45 into the middle quarter gallery slot. On top of this a Quarter Gallery Spacer (51), from the 0.8mm ply sheet. This part sets the correct angle to part 45. **NOTE:** You will need to bevel the upper side of the tab on part 45 to achieve the correct angle.

202. Now sand the tab on another part 45 that you previously shaped, and glue into position in the top slot so it sits angled to the top of the spacer. Fit the same parts 45 to the opposite side of the hull. **IMPORTANT NOTE:** When you raised the stern counter and fitted higher, the top of the bulwarks will be around 2mm lower than the top of the transom and not level with it as you see here. This was changed as you'll see in Step 313.

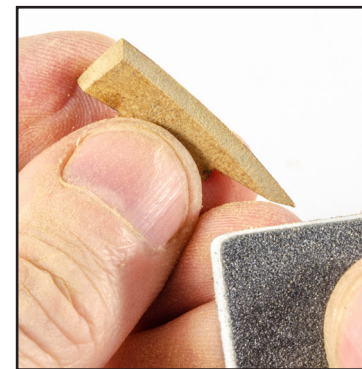
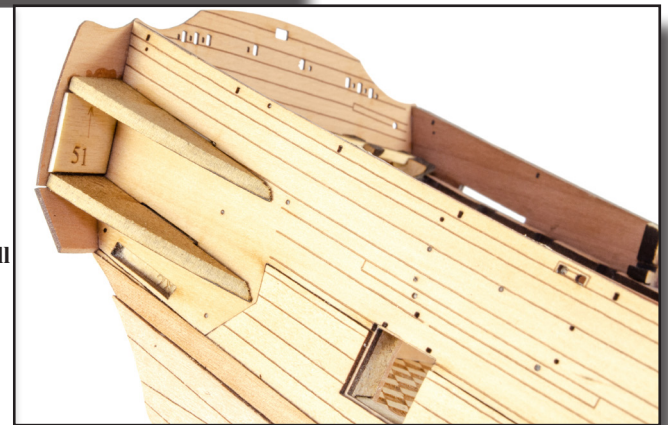

203. Take a part 45a and bevel the rear of the part as you did with the others. Now, bevel the underside edge of this part instead of the upper edge.



204. Glue into position in the lower slot. Repeat for the other side of the hull.



205. Before we can paint the wales and the inside of the galleries, fill all of the pin holes on the wales (not the scupper holes) and sand them with fine paper (320 or 400 grit). Don't damage the engravings. Now mask the whole model apart from the wales (both the wide and narrow wales) and the inner gallery areas. Make sure you take your time masking the model to prevent any paint bleed. We suggest using a fine metal edge and a cotton bud to ensure all edges are fully pressed against the model.



206. Paint the wales and inner galleries in black. For the prototype, we used Plastikote Black.



207. From the 0.6mm wood sheet, remove the Stern Upper Counter Pattern – Outer (75).



208. Glue this in position over the lower counter pattern as seen here. You may need to slightly adjust the fit and/or bevel the adjoining edges to minimise any gap. Gaps will be hidden later with trim strip. Try not to pin this part, but if you do, you'll be able to fill any holes as it will be painted blue.

209 (Below). From the 1mm wood sheet, remove the Stern Fascia Pattern – Outer (157).

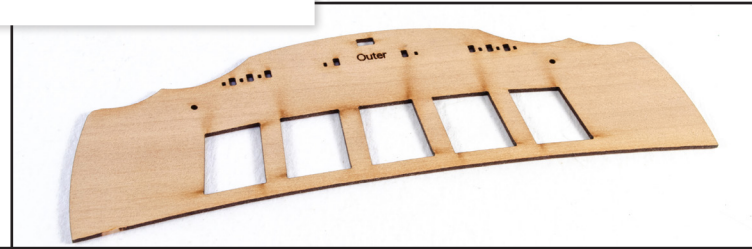

210. Glue this into position directly over the inner pattern. Again, bevelling the lower edge will help with fit. You can pin this, but we found a series of clamps around the top and side was enough to hold it until dry.

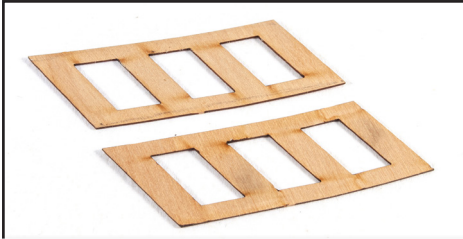

211. From the 0.6mm wood sheet, remove the two Quarter Gallery Window Patterns – Inner (89).

212. These pieces can only fit one way and are identical. Glue them into position along the top and middle MDF frames, as seen here. The front edge of the part should lie roughly where the angled engrave line is. You can trim the part to suit your model.



217. Glue the Quarter Gallery Window Patterns -Outer, to the model as shown. NOTE: One side of these parts is slightly wider. That side MUST go to the front. This is to cater to the extra small length you'll need for the part to reach the hull side.

You can bevel that edge to match to the hull side. You may need to trim these parts to suit your build. Now fit the Quarter Gallery Upper Patterns (the roof) of the gallery. Again, you may need to trim the length and width to suit your model. As a guide, the 'roof' shouldn't really protrude beyond the stern fascia, and it also shouldn't really overlap the window pattern.

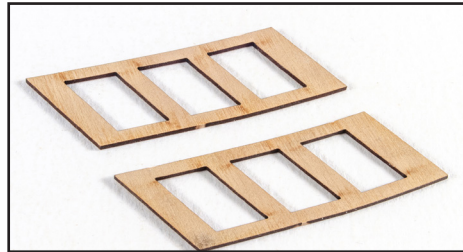

213. From the 1mm wood sheet, remove the two Quarter Gallery Window Patterns – Outer (158).



214. Now remove the two Quarter Gallery Upper Patterns (481, 482) from the 4mm wood sheet.

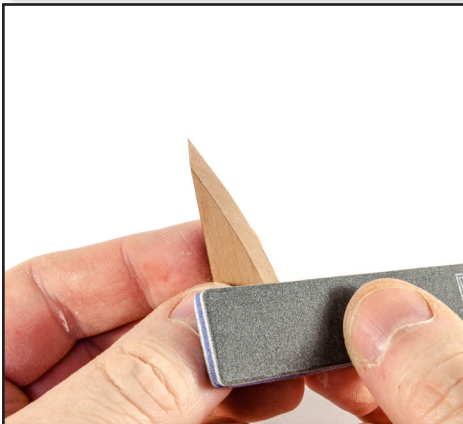

215. Bevel the parts from the lower outer edge to the engraved line on top of each part. A Dremel is good for quick removal and then sanding sticks etc. to finish off the part.



216. The bevelled parts will look like this.



218. Remove the two Quarter Gallery Patterns (45c) from the 2mm MDF sheet.

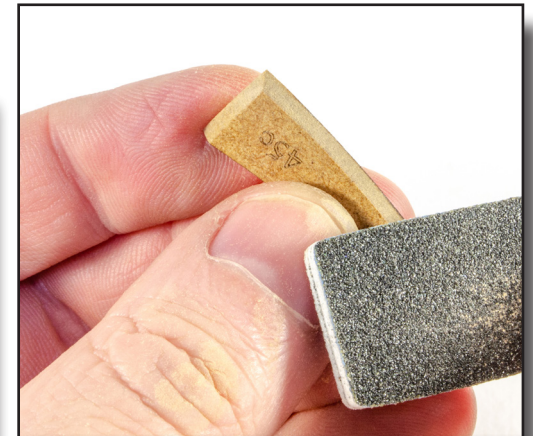

219. Bevel the rear edge to suit the angle of the stern fascia again, and then bevel the lower edge of the parts.



220. Glue these into position as seen here. You may need to alter the length of these depending on how you have built your model.

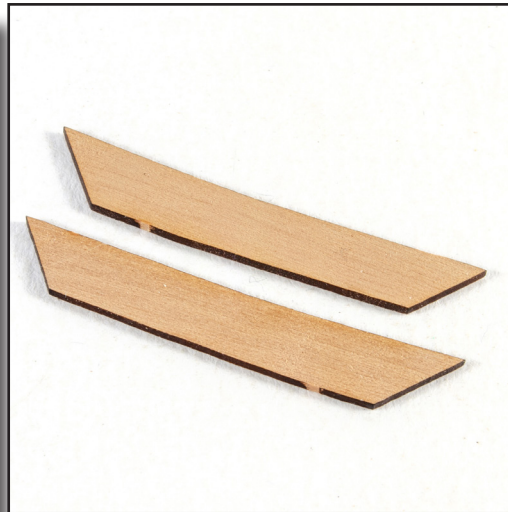

221. From the 1mm wood sheet, remove the two Quarter Gallery Berthing Patterns (159).



225. Glue the MDF parts together as seen here, with the 3mm part at the top and the 2mm below, followed by the two small parts at the bottom. Make sure all parts are up against the hull but DO NOT glue them to the hull at this stage. Leave the MDF parts to set.



226. Remove the MDF parts from the hull and start to shape them. These will be more or less flush with the lower part of the gallery (continuing the angle of that part). Occasionally place the MDF back to the hull to test the fit.



222. Glue these into position as shown here. You will need to trim these to suit your own model, and also bevel the upper inside edge so it meets the window area properly.



223. From the 3mm MDF sheet, remove the two Quarter Gallery Lower Finishing Patterns (29). From the 2mm MDF sheet, remove the two Quarter Gallery Patterns (45b), and the four small Lower Quarter Gallery Finishing Patterns (46).



227. When shaped, the MDF will look like this. Note that whilst the front edge is tapered to a fine edge, the rear side is not.



228. In position, this is what the MDF will look like. These can now be glued to the model, scraping a little of the black paint from the wales first.



224. Glue parts 46 together in pairs.

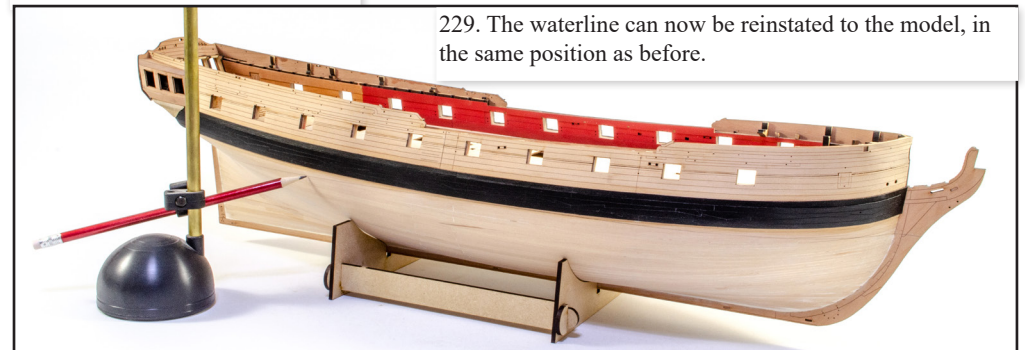

229. The waterline can now be reinstated to the model, in the same position as before.



230. Carefully mask the waterline and ensure you have a good, sealed joint. Use a suitable filler (we suggest acrylic) and dilute the mixture before applying with a brush. When dry, sand the filler back to the wood and re-do this until you have a good surface with no cracks or holes.

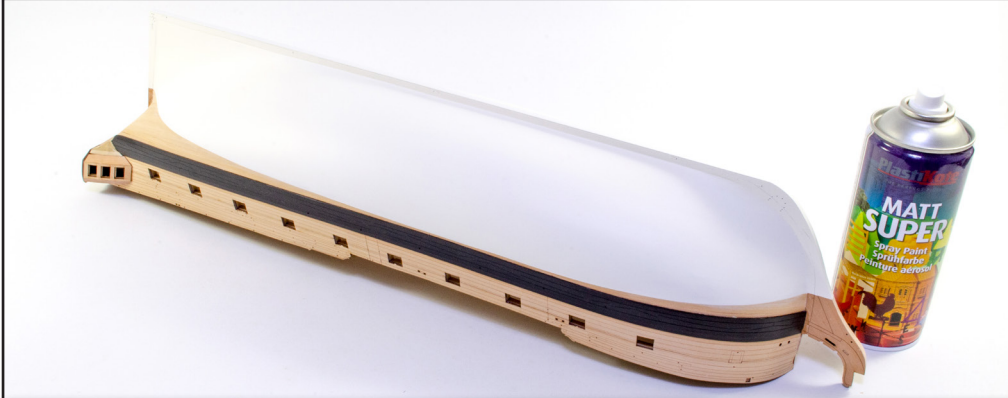

231. Apply thin coats of your chosen paint to the underside of the hull, checking for any defects as you proceed. You will likely need to continue sanding and filling as check for any surface defects. Continue until you have a smooth, defect-free lower hull. Leave to dry and then remove masking tape.

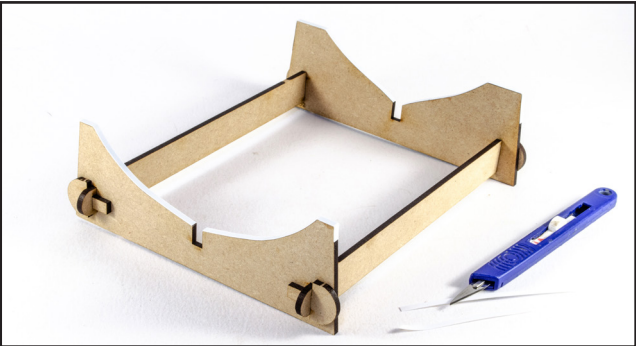

232. As white can be easily marked, either lay a cloth over your cradle, or apply something to the contact edges to protect your hull paint. I have used Plasticard strip. NOTE: If you use baize/felt, please be careful as the colour may leech from this and stain your paintwork.



233. From the 1mm wood sheet, remove the two Sheer and Waist Rail Patterns – Front (143, 147).

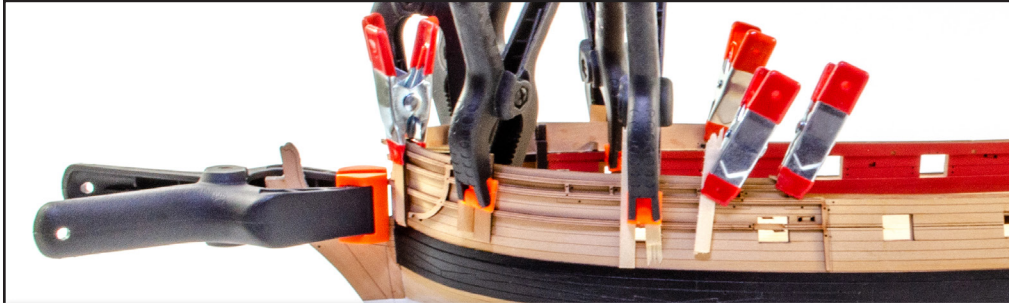

234. Soak these parts for 20 minutes in hot water and then clamp in position until dry. We suggest leaving them dry overnight so any expansion is gone. NOTE: These parts are very fragile, and to clamp them, we suggest using scrap planks from the infill area you removed from the parts, to use as batons across the rails so even pressure is applied to them with the clamps. It also means less clamps are needed and reduced risk of the clamps damaging the parts. You can see this clearly in the photos.



235. Remove the parts from the hull and set aside somewhere safe until later.

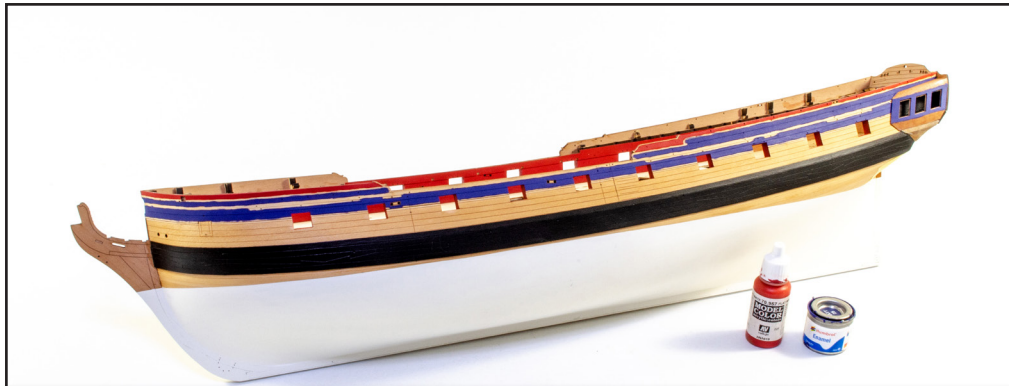

236. Varnish all of the hull above the waterline, except for the areas where the rail sections and channels will be glued. Now paint blue and red into their respective areas. You may need a couple of coats to achieve a good finish. We use Humbrol 25 Flat Blue enamel and Vallejo Flat Red acrylic for this.



237. From the 1mm wood sheet, remove the Sheer Rail Patterns – Left & Right (140, 144).

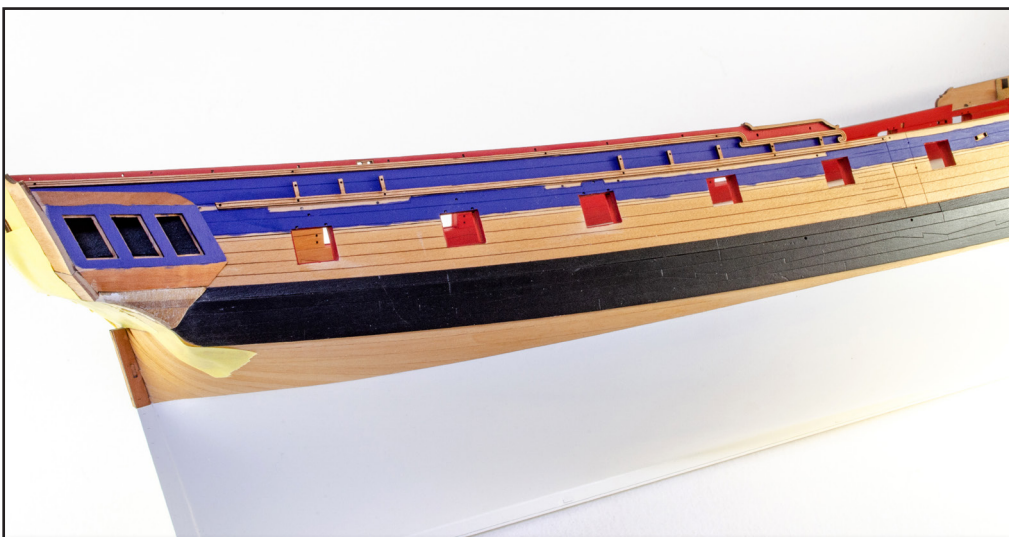

238. Glue each one into their respective position on the hull side, as seen here. For our prototype, we used wood glue and a series of small clamps to hold until set.

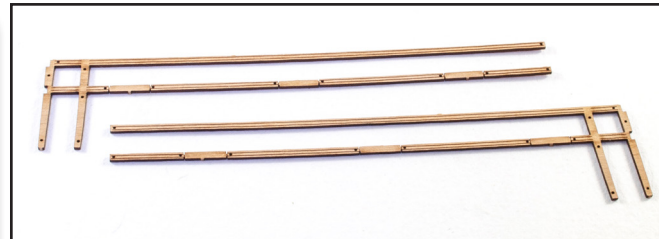

239. From the same 1mm wood sheet, remove the Sheer & Waist Rail Patterns – Left & Right (142, 146).

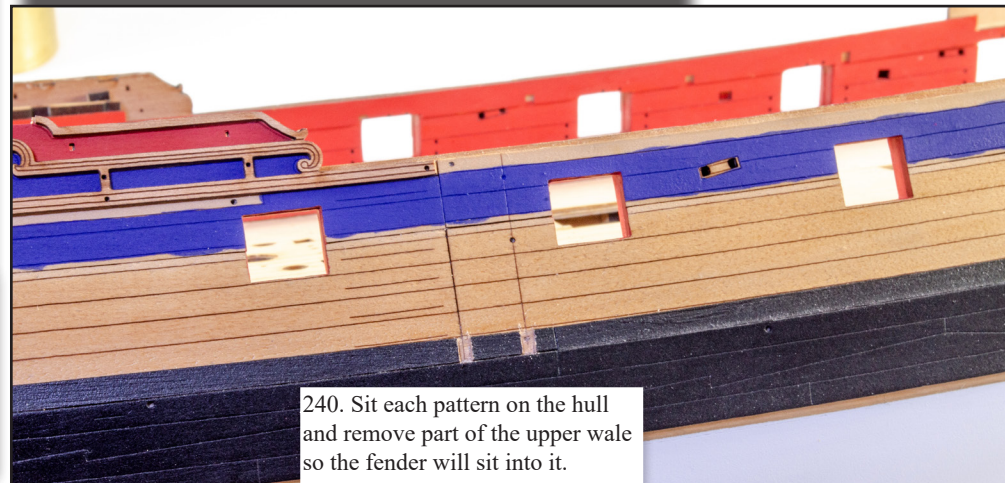

240. Sit each pattern on the hull and remove part of the upper wale so the fender will sit into it.



241. Now glue and clamp the Sheer & Waist Rail Patterns into position as shown here. Note how a notch in this matches up with the previous rail pattern. The rails will sit across the cannon ports.

242. From the same 1mm wood sheet, remove the Waist Rail Patterns – Left & Right (141, 145).

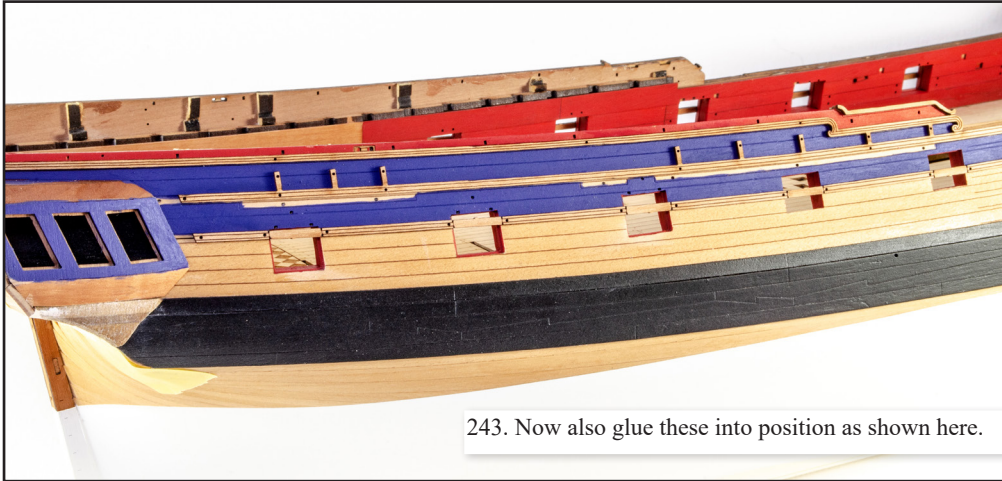

243. Now also glue these into position as shown here.

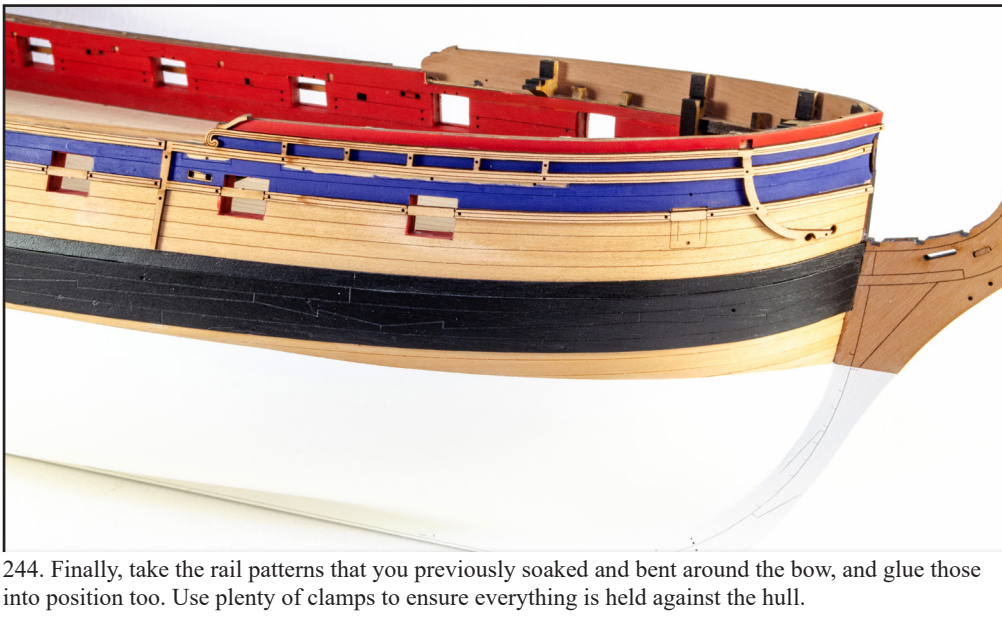

244. Finally, take the rail patterns that you previously soaked and bent around the bow, and glue those into position too. Use plenty of clamps to ensure everything is held against the hull.

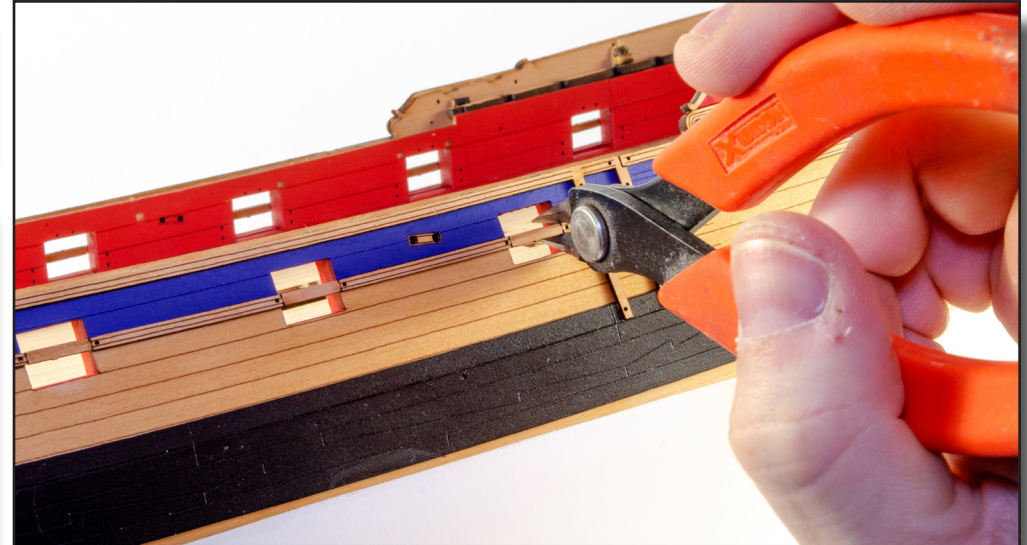

245. When all the rails are dry, use sharp cutters to snip out the parts that cross over the gunports. These are partially cut through with laser, so will be easy to remove. Clean up any edges if necessary.

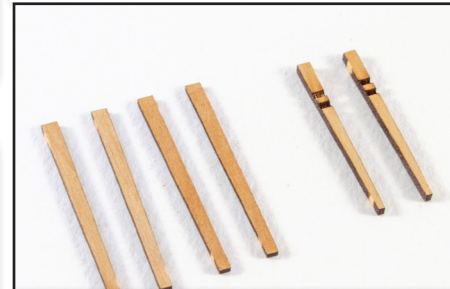

246. From the 1mm wood sheet, remove four Side Fender Patterns (148), and from the 1.5mm wood sheet, remove two Chess Tree Patterns (383).



247. Glue two of the Side Fender Patterns into place as seen here, on the waist rail pattern. Repeat both sides.



248. Glue the Chess Tree Patterns into position as shown, just after of the fore channel positions.

249. With all rails fitted, your hull should look something like this.

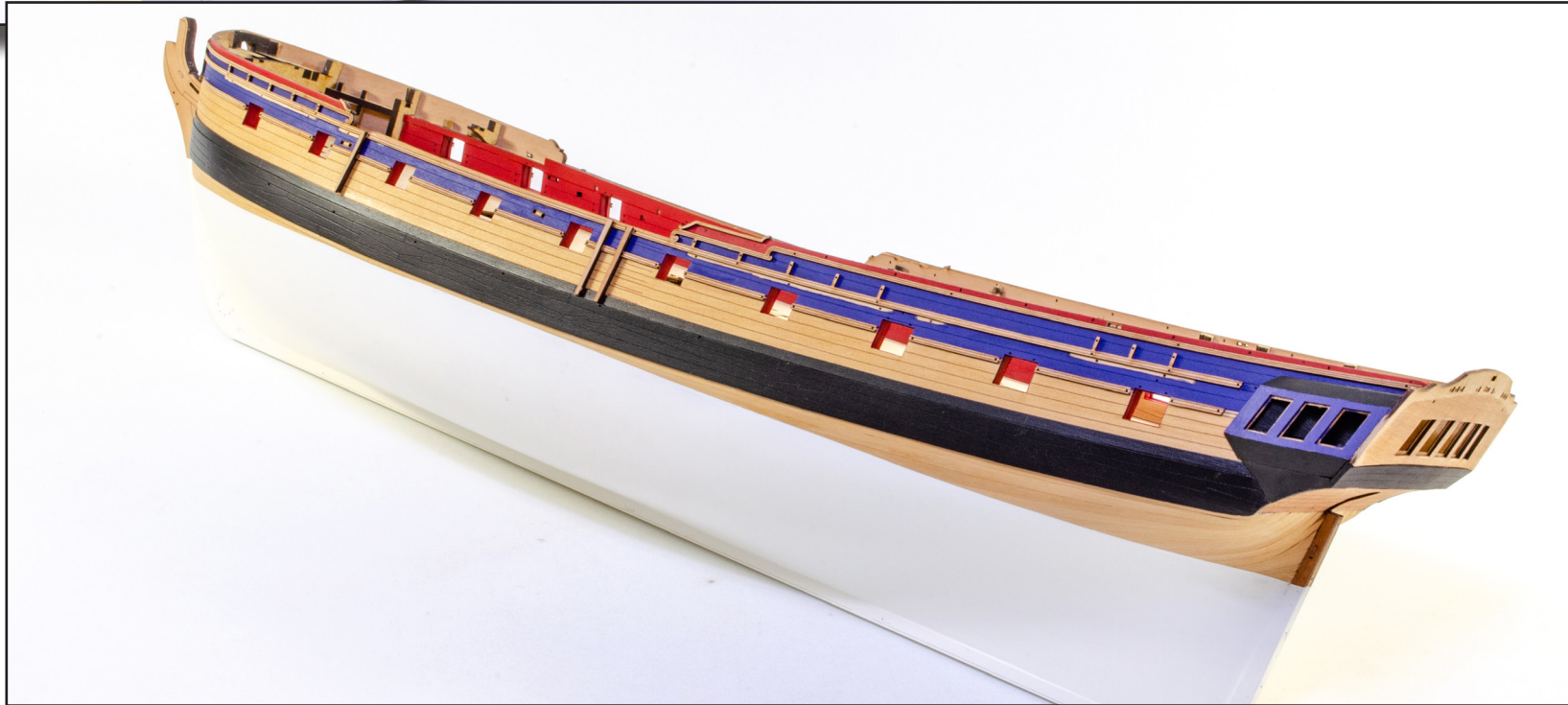



251. Glue both outer rudder patterns to the 3mm rudder pattern. OPTIONAL: You can slightly taper the rudder before adding the outer patterns. See plans.

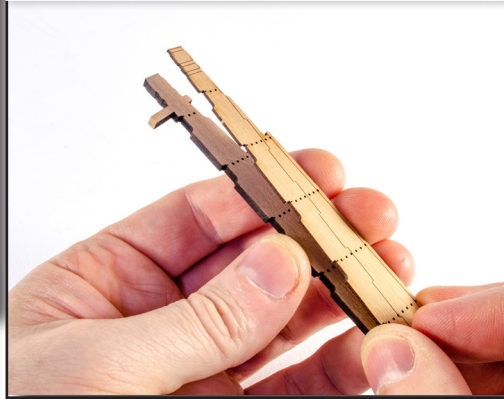

250. From the 3mm wood sheet, remove the Rudder Pattern (448), and from the 1mm wood sheet, remove the two Rudder Outer Patterns – Left & Right (194, 195).

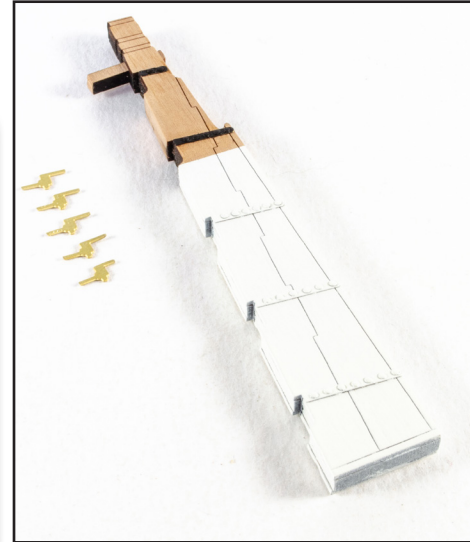

255. Sit the rudder against the hull and mark the waterline onto it. Mask and spray white. From the 0.6mm PE sheet, remove the five Rudder and Gudgeon Pintle Patterns.

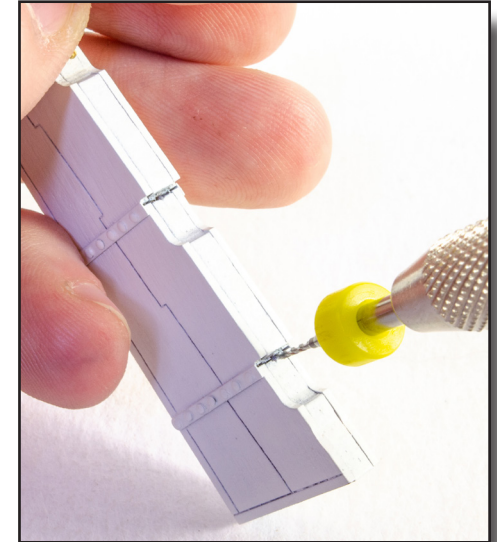

256. If you look at the hinge side of the rudder, you'll notice an engraved slot. Use a 0.6mm drill and drill into the middle of this slot, at right angles to the rudder. Drill about 5mm deep.

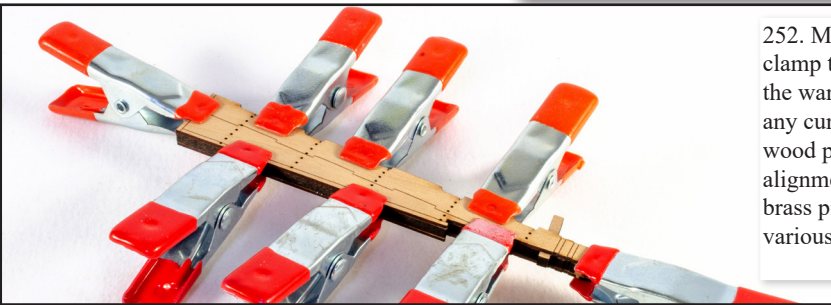

252. Make sure you clamp the assembly all of the way around to prevent any curling of the 1mm wood parts. To help with alignment, you can use brass pins through the various holes.

253. From the 0.2mm PE sheet, remove the Rudder Pintle Straps (PE-31 thru PE-35). Use a file to make sure the ends are properly finished.

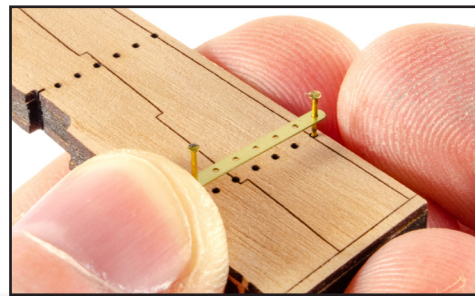
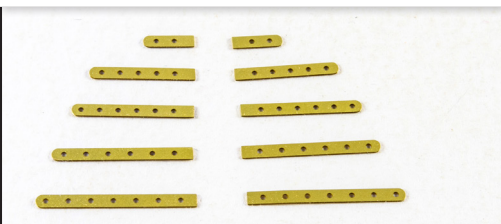

254. Use your brass pins to align the pintle straps to the rudder, and CA to glue them in place. You can, if you wish, insert all pins and then add the pintle straps to the opposite side and fit over the protruding nails, before cutting them flush. However, we prefer to cut the pins short (2mm) and glue one into each hole from either side to give the same domed nail look. If you do this, please keep the cut-off pins as they will soon be useful.

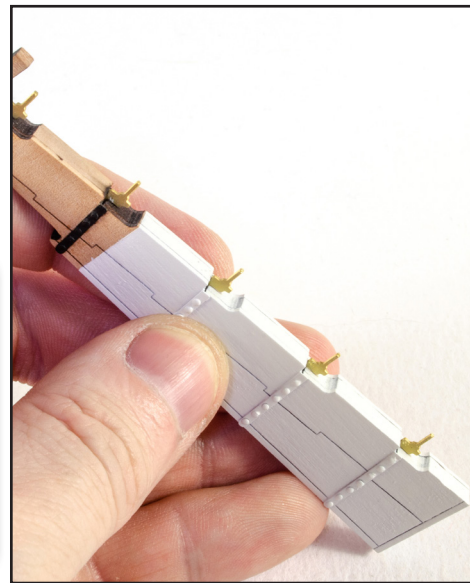

257. Glue the Rudder and Gudgeon Pintle Patterns into place like this. Note their orientation here and against the drawings.

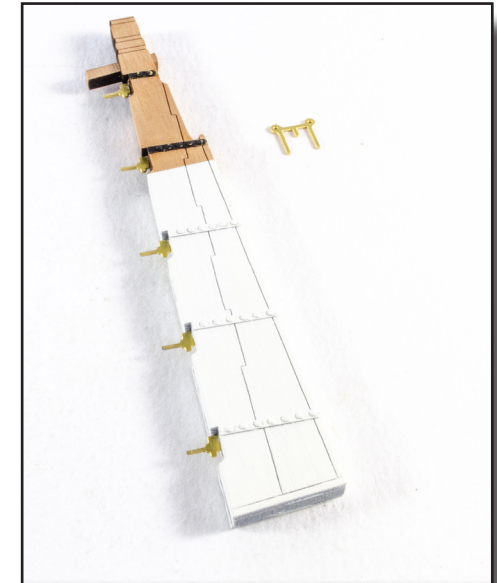

258. From the 0.6mm PE sheet, remove the Rudder Spectacle Plate (PE-153).

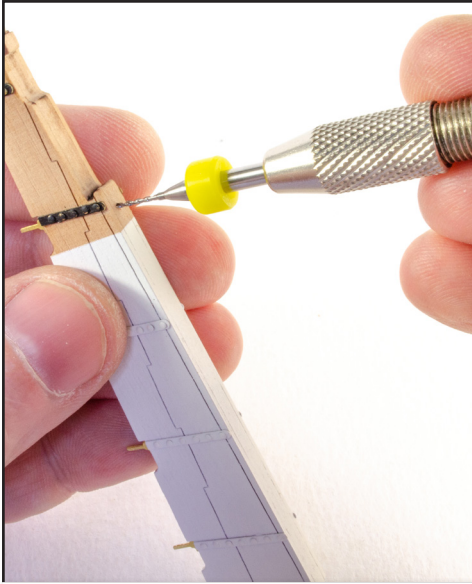

259. Push into place on the rudder so the pin makes a mark on the rear of the rudder. Remove the part and drill into the rudder using a 0.6mm drill, in the marked position.

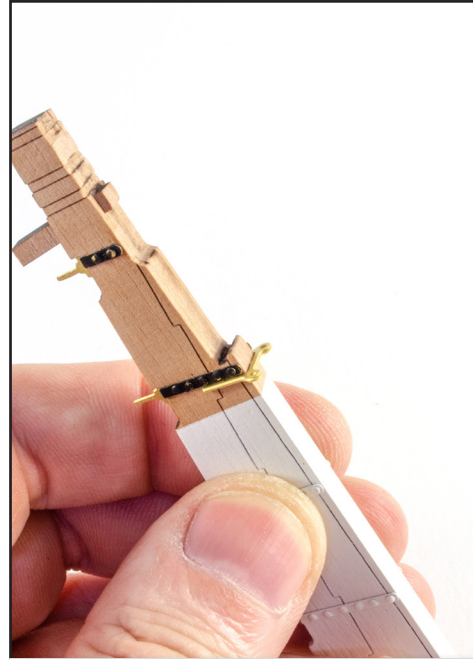

260. Glue the PE part into place as shown.

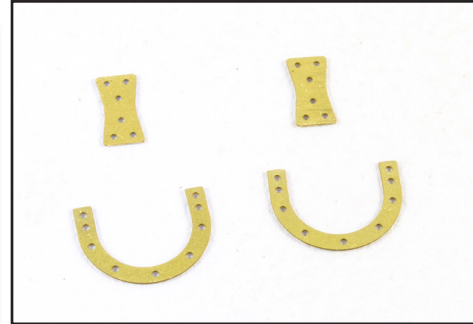

262. From the 0.2mm PE sheet, remove the two Prow Horseshoe Plates (PE-27), and the two Stern Fishplates (PE-28).



263. Prime and then paint the PE parts in copper paint. Fit the horseshoe parts as seen here. On our prototype, we use cut off brass pins on both sides as we did with the rudder. Paint the brass pins in copper also.

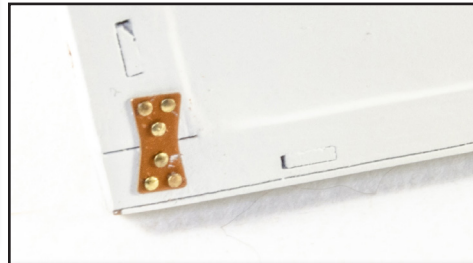

264. Now fit the two fishplates in the same way as the horseshoe plates.

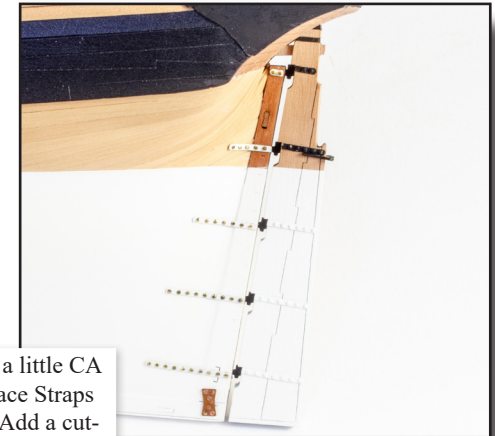

265. The rudder can now be glued into position using a little CA gel. From the 0.2mm PE sheet, now fit the Rudder Brace Straps (PE-36 thru PE-40). Also use drawings for reference. Add a cut-off brass pin into each hole. When complete, paint the straps and pins in white.

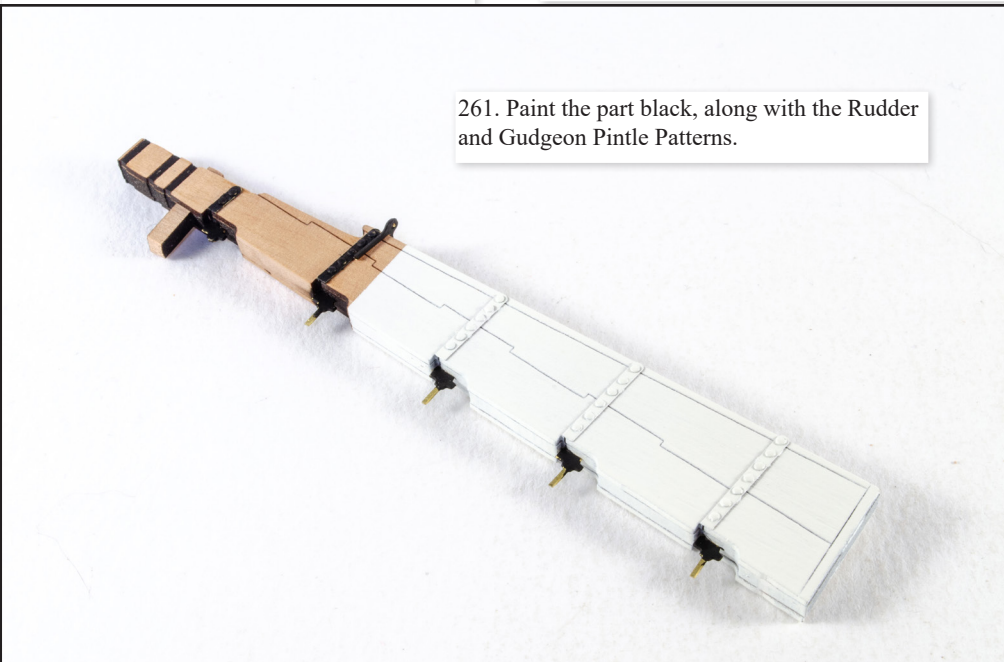

261. Paint the part black, along with the Rudder and Gudgeon Pintle Patterns.

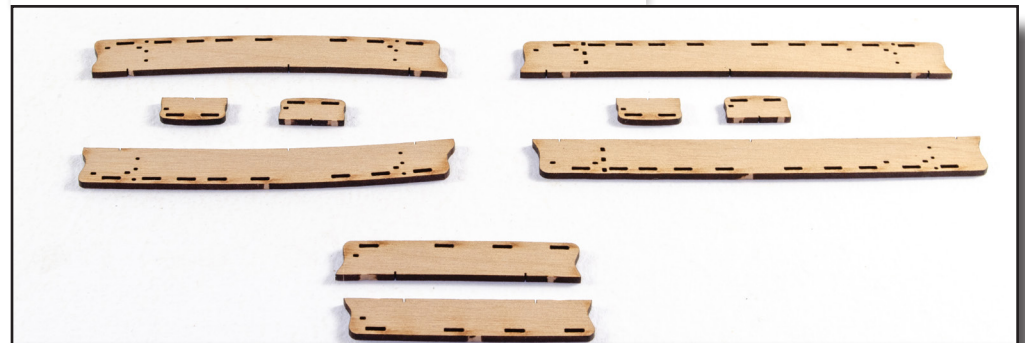

266. From the 1.5mm wood sheet, remove the two Fore Channels (373), two Main Channels (374), and the two Mizzen Channels (375). Also remove the four Fore and Main Stools (376). These are identical, of course, for both fore and main positions. Sand these with a very fine grade paper and then seal with varnish.



267. You'll notice a laser cut line on the edges. In the middle of this, drill a hole into the channels using a 0.6mm drill bit.



268. Paint the channels in black and now take a number of the cut-off pin lengths from your previous stages and cut to length and glue into the holes. The pointed end should stick out around 2mm, as a guide.

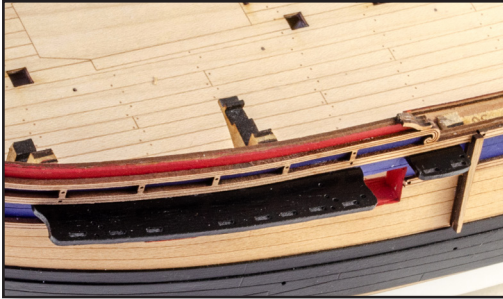

269. Glue the fore channels into position as shown. The bottom face of these will be parallel to the waterlines, and also run with the sheer curve of the rail under which they fit. This applies to all channels. Also fit the Fore Stool parts.



270. Now fit the main channels and main stools in the same manner.

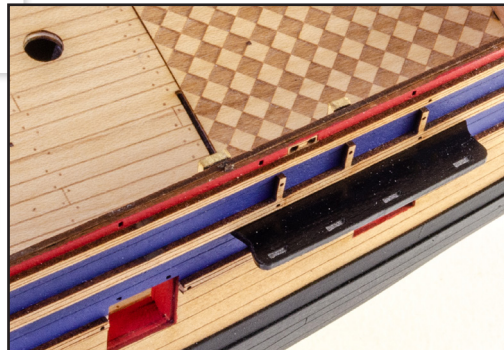

271. Finally, fit the mizzen channels.



272. On the 1.5mm parts sheet, you will see a number of Channel Knee parts for each of the channels. For the Fore Channels, you will see these as parts 377, 378 and 379. Parts 377 are designed to fit at the front of the channel, 378 around the middle, and 379 at the rear. There is no hard and fast rule to this, and you may find that you can mix and match these to the specific curve of your hull. Just make sure there is good contact to both the rail and channel. NOTE: It's advised you scrape away any black paint where necessary. This can be touched up later if needed.

273. Fit the Channel Knees (380, 381) to the main channels. There are two sizes here for the two different rail connection points. If necessary, you can adjust the angle, so you achieve a good fit to the rail and the channel.



274. Now fit the Mizzen Channel Knees (382) in the same way.

275. Your HMS Sphinx should now look like this.



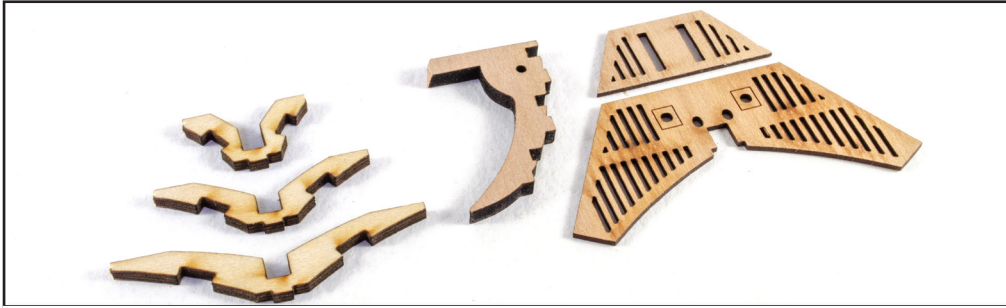

276. We can start to work on the bow area now. From the 2mm Ply sheets, remove the Bow V-Patterns (42, 43, 44). Note there are two sets of these in case you need to replace one. From the 3mm wood sheet, remove the Gammoning Knee (449). From the 1mm wood sheet, remove the Bow Grating Pattern – Inner (160) and the Bow Grating Pattern – Outer (161).



277. Using a file, bevel one side of the slots on each V-bracket, as shown. On the prototype, we angled these about 45 degrees.



278. Glue the V-brackets to the Gammoning Knee, with the V-bracket bevels pointing forward.



279. Sit (DO NOT GLUE) the assembly on the model. Note that the tops of the V-brackets are bevelled for contact with the gratings.

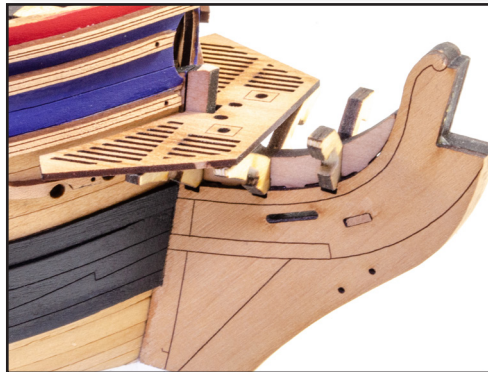

280. Take the Inner Bow Grating and test fit to the model. Adjust as necessary and glue to the tops of the V-brackets as shown.

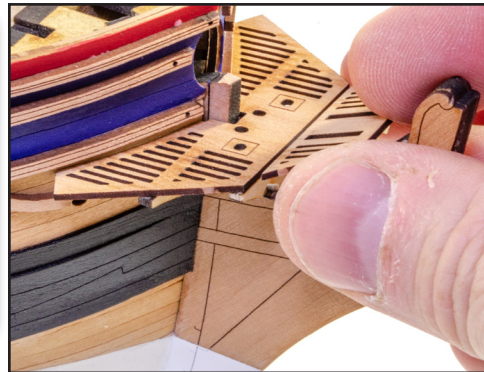

281. Take the Bow Grating – Outer and glue into position. The top of the fore V-bracket is filed so it sits properly.

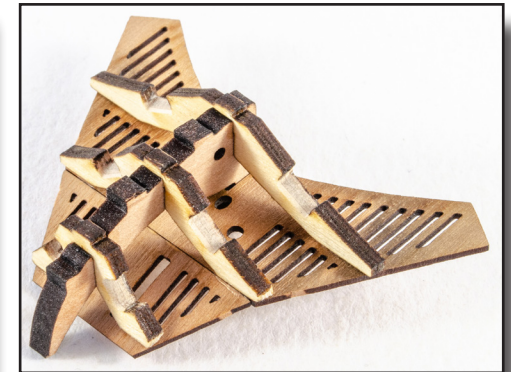

282. When removed, the grating assembly will look like this.

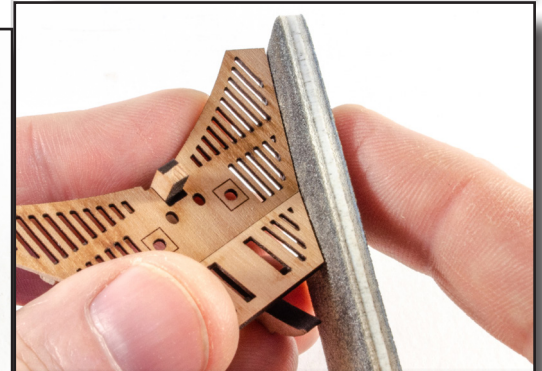
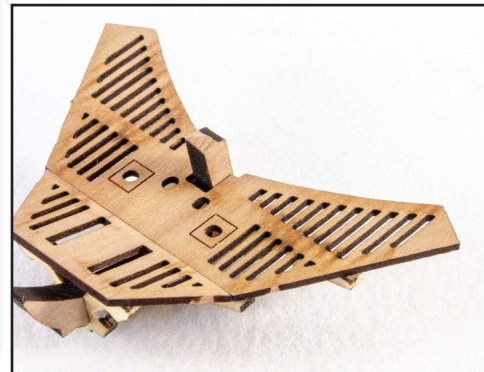

283. Using sandpaper/stick remove any of the V-brackets that protrude from the sides of the gratings.

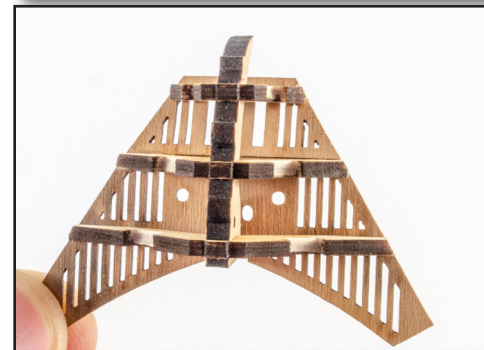

284. Take a file and also shape the bottom of the brackets so they follow the curve of the underside of the Gammoning Knee. At this point, you can now paint the V-brackets in black if you wish.

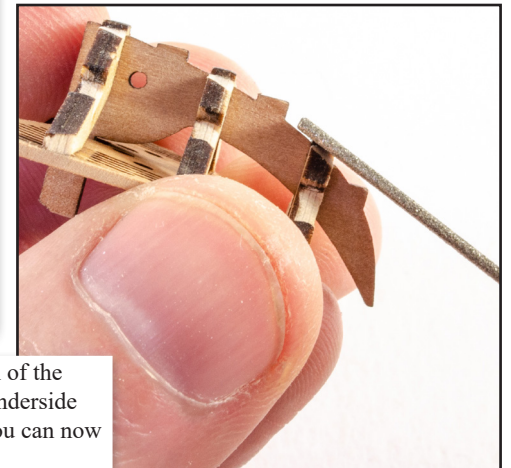



285. Glue the bow grating assembly into position on your hull.



290. From the 2mm wood sheet, remove the four Bow Cheeks (432). From the 1.5mm wood sheet, remove the two Hawse Bolsters (384).



286. From the 1mm wood sheet, remove the Bow Hair Brackets – Right & Left (171, 173), and the Bow Lower Rail – Right & Left (172, 174). There are two sets of these in case you need any spares.



287. Glue the parts onto each side of the prow as shown here. Engravings on the prow give the exact positions.



288. From the 0.6mm wood sheet, remove the 'Ekeing' Moulding Patterns – Right & Left (79, 80). There are two sets of these in case you need any spares.

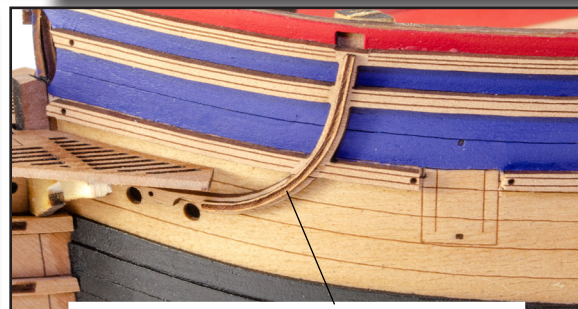

289. Glue these into position as shown here.

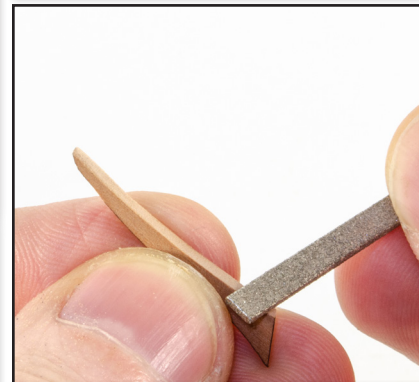

291. The Bow Cheeks will need a little beveling where they meet the hull and the prow. Check your beveling so ensure a good fit.



292. Glue the Bow Cheeks into position as shown. These will sit on top of the rails you recently fitted to the prow.



293. Open up the hawse holes gradually until they are around 4mm diameter. Round off the upper edges of the Hawse Bolsters and glue into position directly under the hawse holes. You may need to sand the bottom edge of the part so it isn't too tall. NOTE that the part slipped in this photo and isn't aligned properly! You'll see the correct position a few photos ahead!



294. From the 3mm wood sheet, remove the two Wash Cants (450).

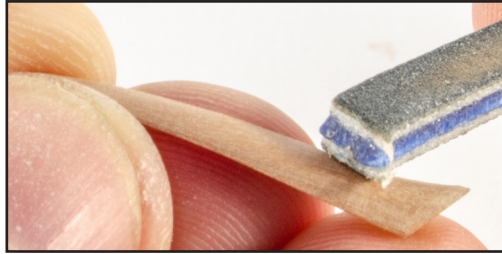

295. These must be shaped on the underside. Aim to create a properly bevelled part and not just to round the edges. It should be fairly streamlined.



296. Glue the parts into position as shown. All of these newly added bow parts can now be painted black.



297. From the 0.8mm wood sheet, remove the two Bow Lower Rails – Left & Right (291, 292). There are two sets of these in case you need a spare.

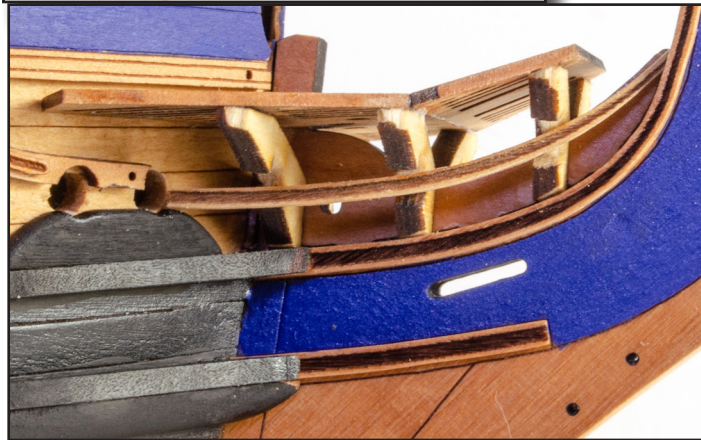

298. The top edge of these should follow the curve of the Gammoning Knee when viewed from the side. The rail glues between the prow and should terminate in the area on the inner side of the inner hawse hole, while sitting in the V-bracket slots. Note that I have also now painted a section of the prow in blue. It's suggested you also do this as you will later have PE décor to fit here.



299. From the 0.6mm wood sheet, remove the V-Shaped Head Rail Pattern parts (81, 82, 83). You will need two of each for this task. There are also a spare set of parts in case you need a spare.



300. Glue the V-shaped head rail patterns into place on the edges of the V-brackets as seen here, trapping the lower rail. You may need to trim the patterns to suit.

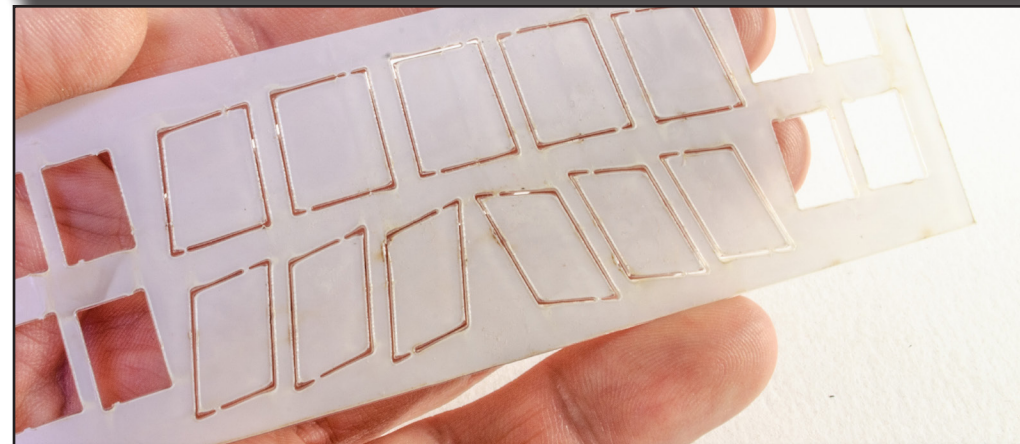

301. We now turn our attention to the stern area, and you will need your acetate sheet of laser-cut windows.



302. Test fit and glue the windows into the recesses on the quarter galleries and stern, using the numbering on your plans. You may need to file these a little to make them fit. Clear acrylic varnish was used to glue these into position as CA can fog the transparencies.



306. Glue the Stern Column Panel as shown here. This will sit directly above the window frames and the bottom of the columns will align with the bottom of window frames. We used CA gel to fit this as it allows some time to move the part. Now fit the Quarter Gallery Vertical Columns. Note these protrude evenly beyond the top and bottom of the window frames.

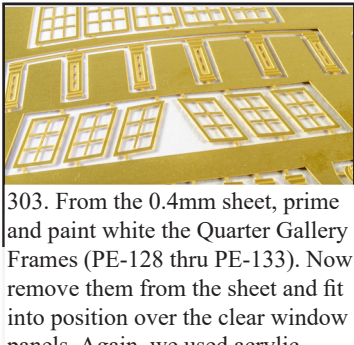

303. From the 0.4mm sheet, prime and paint white the Quarter Gallery Frames (PE-128 thru PE-133). Now remove them from the sheet and fit into position over the clear window panels. Again, we used acrylic varnish to hold these in place.



304. Your windows will look like this when fitted.

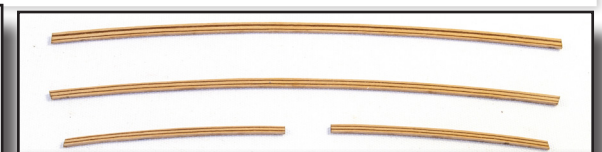

307. From the 0.8mm wood sheet, remove the Stern Wing Transom Rails – Left & Right (279, 280), the Stern Lower Counter Rail (281) and the Stern Upper Counter Rail (282).

308. Fit the rails as seen here and on your plan. Note the upper rail sits DIRECTLY below the columns and windows on stern.

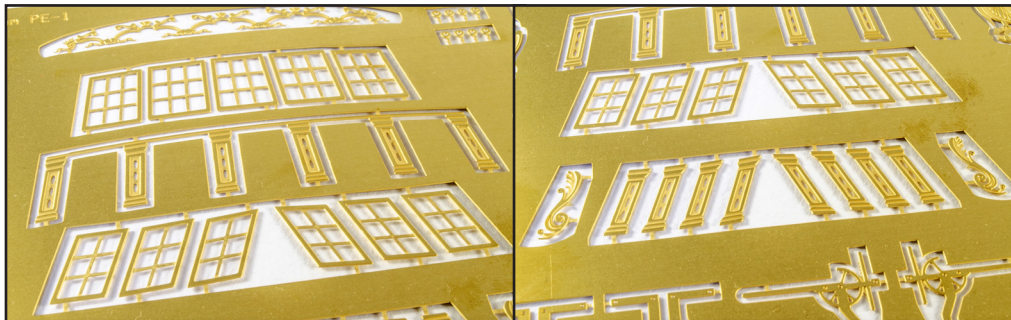

305. Now prime and paint gold the Stern Column Decoration Panel (PE-126) on the 0.4mm PE sheet, and the Quarter Gallery Vertical Columns (PE-134 thru PE-141), also on the 0.4mm PE sheet.



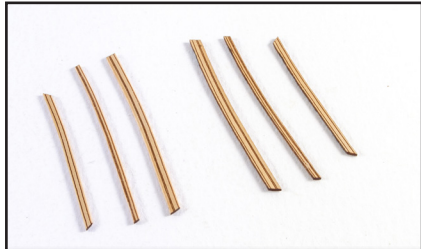

309. From the 0.8mm wood sheet, remove the Quarter Gallery Rails – Upper/Middle/Lower for both left and right sides (285, 286, 287, 288, 289, 290).



310. Fit these as shown here and on plan. You can bevel the front edge where they meet the hull, but the two lower rails MUST also line up with the upper and lower stern rails that you fitted to the stern.

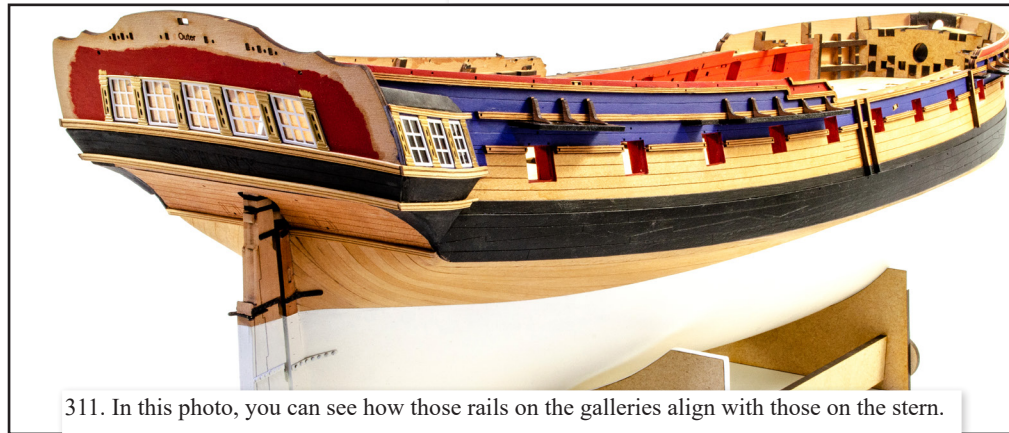

311. In this photo, you can see how those rails on the galleries align with those on the stern.



312. From the 0.8mm wood sheet, remove the Quarter Gallery Upper Fretwork – Left & Right (277, 278).



313. Fit these as shown here and on plan. You may need to trim each side and also bevel/notch to fit against the hull side. A slight bevel may be needed on underside too as the part has a slight lean on it.



314. Take the Stern Decoration (F-2) and carefully remove the casting block as shown. We suggest using a fine razor saw or similar. Use fine sandpaper to then smooth any uneven surface that may be left. Soak this in very hot (just boiled) water for 10 seconds and lay over curved stern. The resin will be floppy and will easily lie over the curve and adopt its shape. Leave a few minutes then run the resin part under cold water and allow to dry.



315. Prime the resin decoration and then paint blue. We use Humbrol Matt 25 for this.





316. Carefully paint the relief in gold. For this, we use Vallejo Liquid Gold, thinned with a few drops of isopropyl (rubbing) alcohol. A size 000 brush is also used. Use varnish to seal your paintwork.



318. Use CA or epoxy to first glue the stern resin decoration into place. If you need to, this can be raised slightly using the small Stern Upper Rail Filling Patterns (283, 284) from the 0.8mm wood sheet (check plans for details). Using CA, glue the previously painted gold Stern Decorations into place above and to the sides of the stern windows. Paint and prime the 'S P H I N X' PE letters (PE-26), and the Upper Stern Counter Decoration (PE-25L, PE-25R). Glue into position as shown here and plan.

317. Prime and paint gold the Stern Decoration (PE-127L, PE-127R), and the Stern Decoration (PE-120) from the 0.4mm PE sheet.

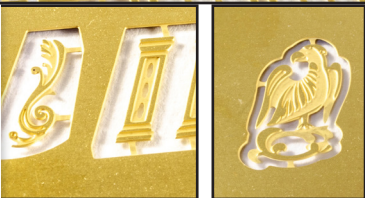

319. From the 0.2mm PE sheet, remove the Upper Finishing Tile Roof parts (PE-21La, PE-21Lb, PE-21Ra, PE-21Rb, PE-22R, PE-22L), and fit to the roof areas as per plan and seen here. (Note: there are now FOUR rows of tiles since the prototype was built). Remove the Lower Quarter Gallery Decoration (PE-23AR, PE-23AL) and fit below the windows (Note: the pattern has changed since this prototype so fit as per plan). Remove the Lower Quarter Gallery Decorations (PE-23AR, PE-23AL) and Lower Quarter Gallery Drop Decorations (PE-24R, PE-24L) and fit them as shown here and on plan.



321. From the 0.6mm wood sheet, remove the Hull Side Step parts (112, 113) and assemble as shown here and on plan.

322. Glue the steps to the side of the hull as marked by laser on the hull. You will also need to fit two on the wales, in line with the others. When fitted, paint the ones in the blue and black areas too match their surroundings.





320. Now it's time to fit all of the frieze parts from the 0.2mm PE sheet. You are advised to prime the metal parts first and then paint/spray them in a bright gold colour. It's advisable to then seal the paint before handling the parts. You can use CA to apply these or paint the frieze areas in an acrylic polish first (such as Klear/Future) and leave to dry. The parts are then seated into their areas and more polish used to run underneath the parts to hold them in place. You will also need to remove the Bow Trail Board Decorations (PE-112L, PE-112R) from the 0.4mm PE sheet and fit to the prow as seen here and on the plan. Note that the slot on these will fit around the prow gammoning slot.

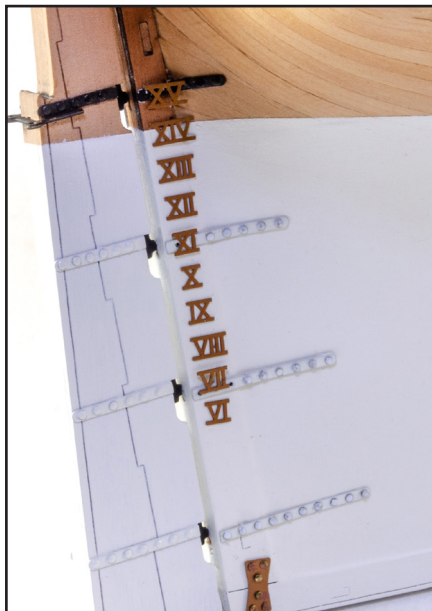

323. From the 0.2mm PE sheet, prime and then paint the Depth Numerals (PE-29) in a copper colour. Use CA to fit these as shown on the stern post. You may need to remove some rudder strap pins to make them fit properly.



324. Now fit the numerals to the prow, as seen here.



325. From the 0.4mm PE sheet, remove the Gun Port Hinge Lids (PE-111) and the Stern Port Lid Hinge (PE-111s). Also remove four of the Gun Port Lid Eyebolt (PE-109).

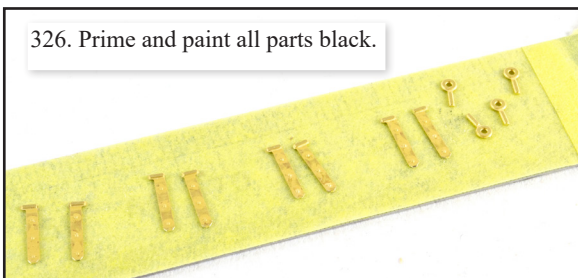

326. Prime and paint all parts black.



327. Glue the bow gun port parts as shown here and on plan and rig the port with 0.1mm natural thread.



328. Now do the same for the stern gun port doors.



330. Follow the plans and fit the deadeye and chainplate assemblies. If you find a particular part is too long or short for a specific point, try to use another size of the same part. There are no real rules here as long as the result closely resembles what you have on your plan. Use brass pins to hold things into position. You will need to cut these shorter where they fasten to the unpainted hull. On the wales, you can use full length as they are below deck height. Use black paint to cover the brass pins and any parts where brass might show through.

329. Before working on the deadeye assemblies, we suggest that you prime and paint black all the associated metalwork for constructing these. These are parts PE-48, PE-49, PE-50, PE-51, PE-52, PE-53, PE-54 and PE-55. Now take the 5mm Deadeye Stroops you just painted (PE-48) and the 3mm Deadeye Stroops (PE-53) and open each in turn with tweezers. Insert the correct deadeye and then close them up again to lock the deadeye into position. Do this for the correct number of 3mm and 5mm deadeye assemblies needed to fit to lower rig positions.





331. Now fit two Standard Eyebolts (PE-106) into place on lower stern rail as seen here, and then fit the Rudder Chain (F-21) as shown here and on plan. On the rudder, the chain fits to the spectacle plate. Use 0.1mm natural thread to rig it at both ends. Seal with CA. The chain will be roughly 5cm to 6cm on either side.



332. Time to turn our attention (at last) to the inner hull. Start by adding the ironwork to the cabin floor areas. These comprise four assemblies of PE-82 and PE-83, from the 0.4mm PE sheet. Paint these black before fitting as shown. NOTE: there are two extra holes in the forward cabin area in front of the mizzen mast position. These are only used if you want to rig the ropes for the steering (not shown for this model). Now also remove the 0.8mm Hole Eyebolts from the 0.4mm PE sheet (after painting) and fit into position around each inner gunport as seen here and on plan sheet. Now remove a Mizzen Mast Base (203) from the 1mm wood sheet, round off the edges and glue into position over the mast hole. Note the inside hole of this is elongated to cater to mast rake. Make sure that elongation runs from bow to stern.

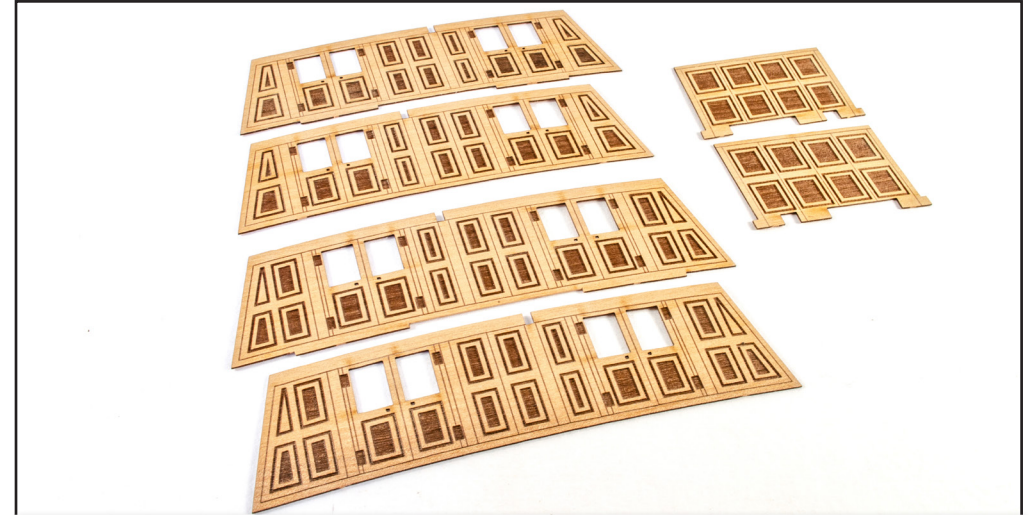

333. From the 0.6mm wood sheet, remove the Forward Gun Deck Cabin Bulkhead parts (59,60), Forward Gun Deck Screen Bulkhead parts (61, 62), and the Aft Gun Deck Cabin Bulkhead parts (62, 64). Note these parts are listed as front or rear/left or right.

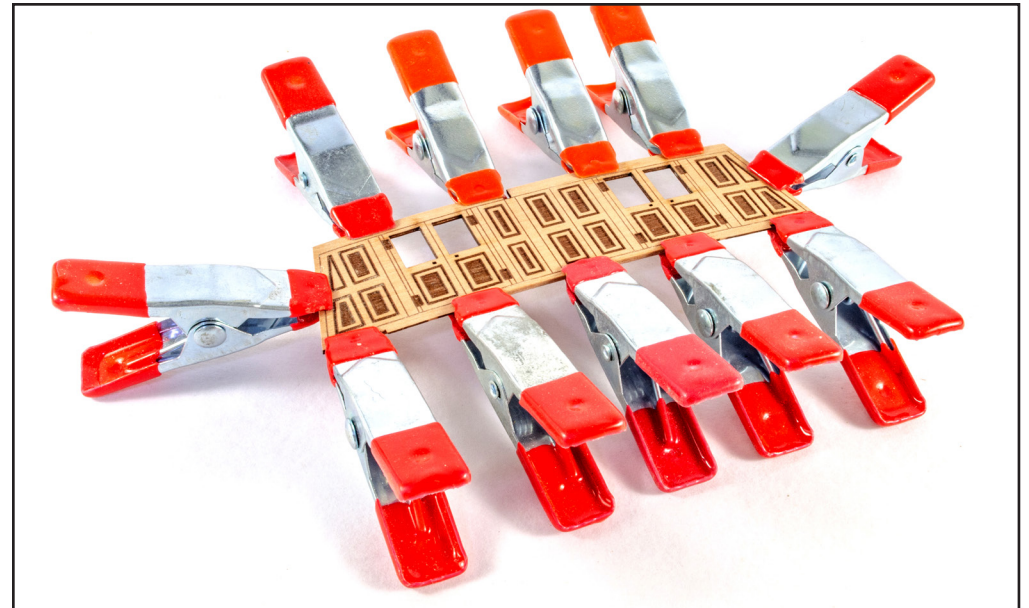

334. Glue the corresponding parts together using wood glue and clamp all the way around so the parts can't curl. It's important to make sure that everything is aligned properly.

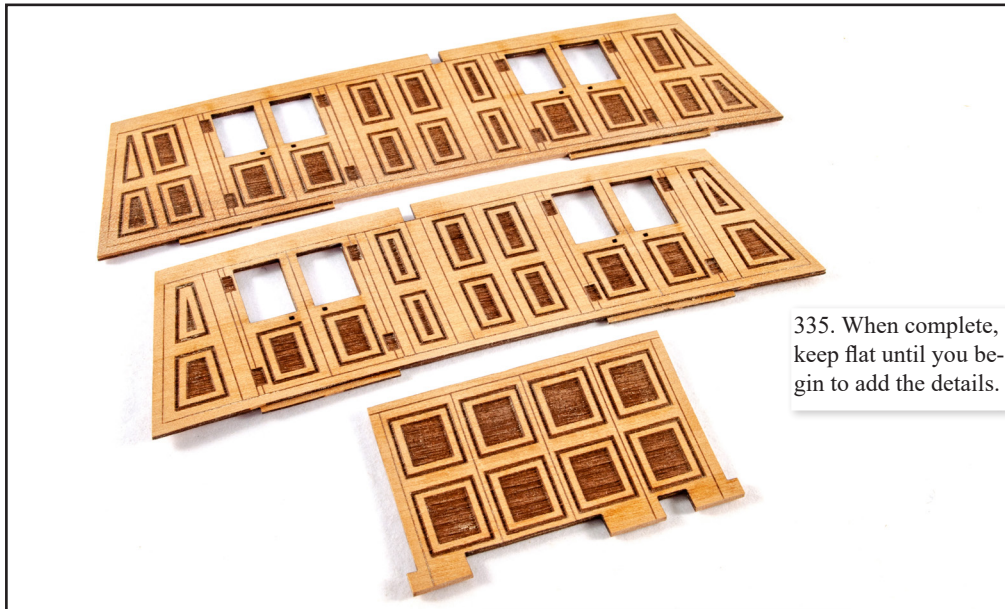

335. When complete, keep flat until you begin to add the details.



336. NOTE: In this photo you see the eyelet detail for the original prototype door handles. Instead, use the Screen Bulkhead Door Handles (PE-119) from the 0.4mm PE sheet. You can still use this detail as reference for the eyelet rings that will fit to the main gun deck floor.



337. Fit the door handles as shown and also the Screen Bulkhead Door Hinges (PE-44B). Use CA for this. You can paint the handles and hinges in black, if you wish.

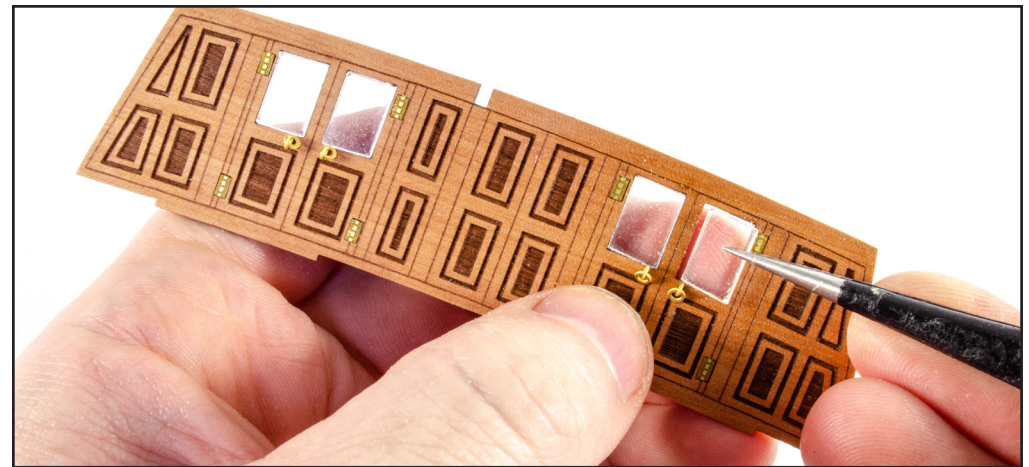

338. The windows can now be fitted. Remove all Aft Cabin Bulkhead Window Glazing (495) from the 0.5mm Clear PETG sheet. Carefully file/sand the edges so they fit neatly into the openings. These shouldn't be too loose. To glue, use either varnish or an odourless CA that won't fog the parts.

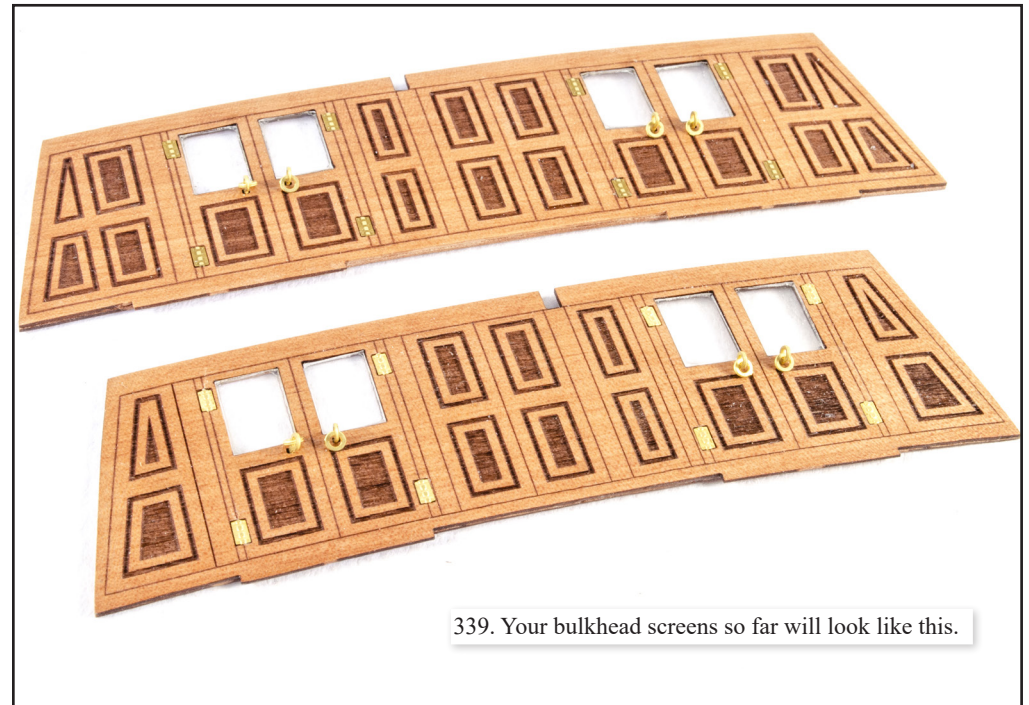

339. Your bulkhead screens so far will look like this.

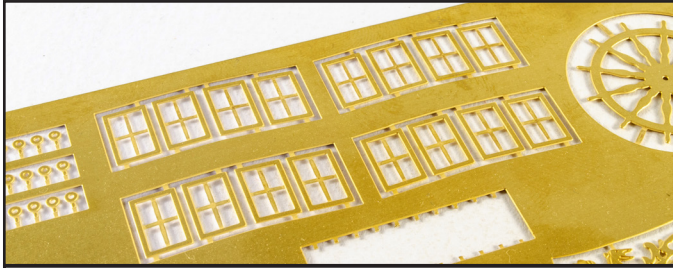

340. On the 0.4mm PE sheet, prime and paint the Screen Bulkhead Window Frames (PE-115, PE-116, PE-117, PE-118). On our prototype, we used Tamiya NATO Brown as it closely resembles the engraved areas of the screens.



341. Use varnish or odourless CA to glue the frames onto the windows.



342. Test fit each screen to the hull, and if the fit is too tight, carefully sand the edges of the bulkhead screens so they neatly fit.

343. From the 3mm wood sheet, remove the Quarterdeck Beams (458A thru 458R)

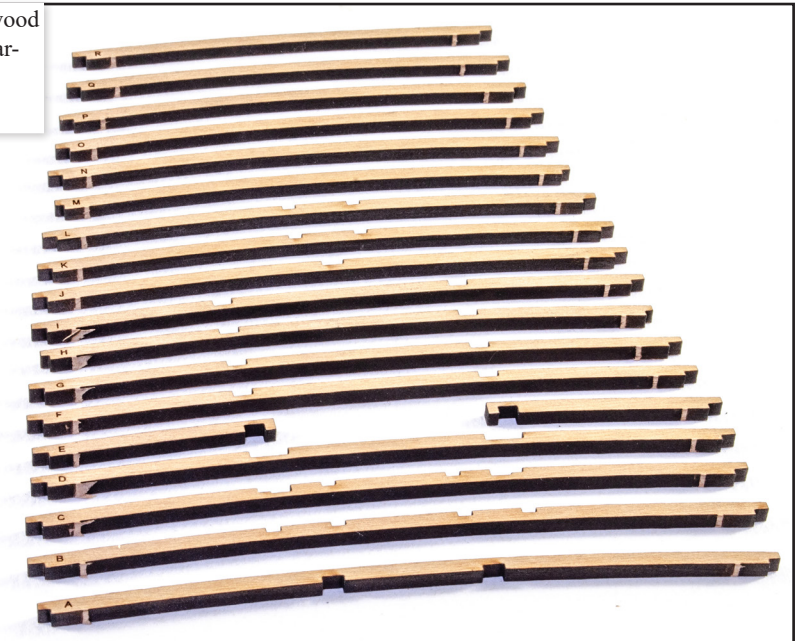

344. Fit and glue into position the rearmost bulkhead screen. Remember, the door hinges on this will face into the rear cabin.



345. To help you ensure this screen is properly upright, you can glue into position Quarterdeck Beam (458M) directly behind it. The screen will sit flat up against this beam. I have also removed the laser char from the upper edges.



346. Now fit the forward Bulkhead Screen into position. Quarterdeck Beam 458I sits in front of the screen, so the screen can sit flat against it. You can also glue that beam into place at this time.

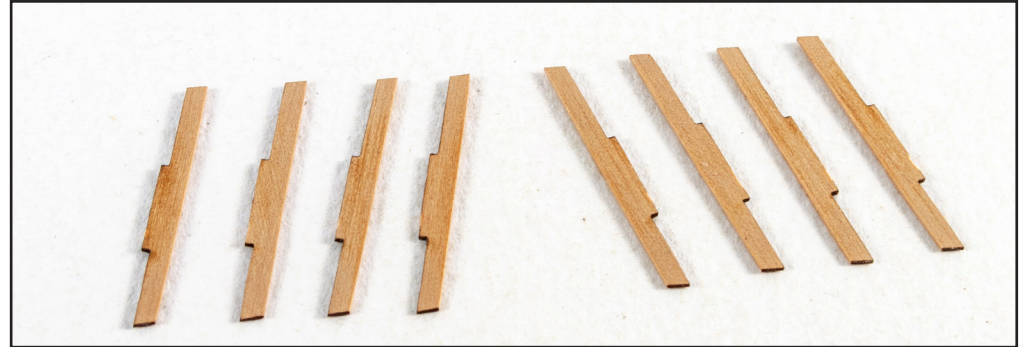

347. From the 0.6mm wood sheet, remove the Cabin Bulkhead Infill Patterns Left & Right (69, 70).



348. Glue these into position as shown here and on plan

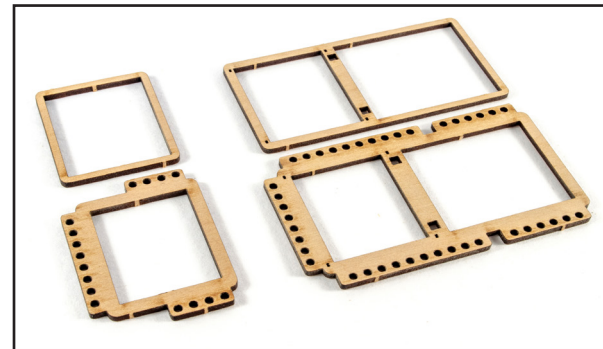

350. From the 1.5mm wood sheet, remove the Gun Deck Forward Hatch Coaming – Lower/Upper parts (353, 354) and also the Gun Deck Main Hatch Coaming – Lower/Upper parts (358, 359).

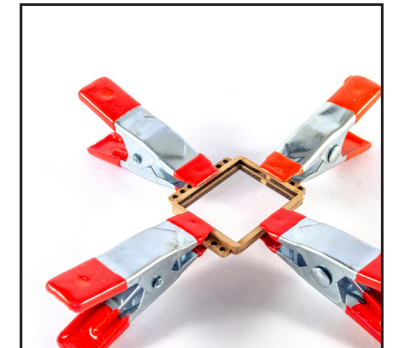

351. Remove all the char from the outside edges and the inner edges where any stairs may fit. Now assemble the upper parts over the lower and clamp until the glue is set.

349. Your HMS Sphinx will now look very much like this.



352. Your finished coamings will look like this.

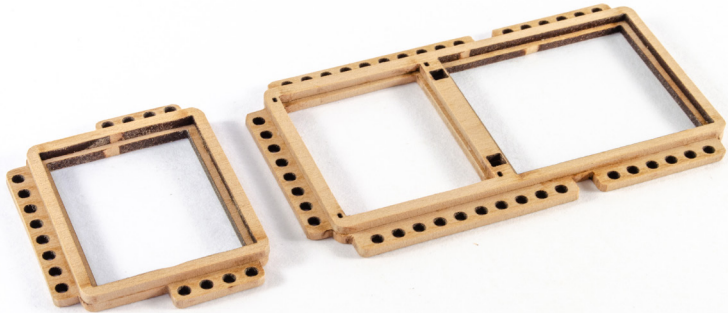

353. From the 1.5mm wood sheet, remove the parts for the Gun Deck Aft Hatch Coaming (361, 361) and the parts for the Gun Deck Aft Ladder Coaming (364, 365).

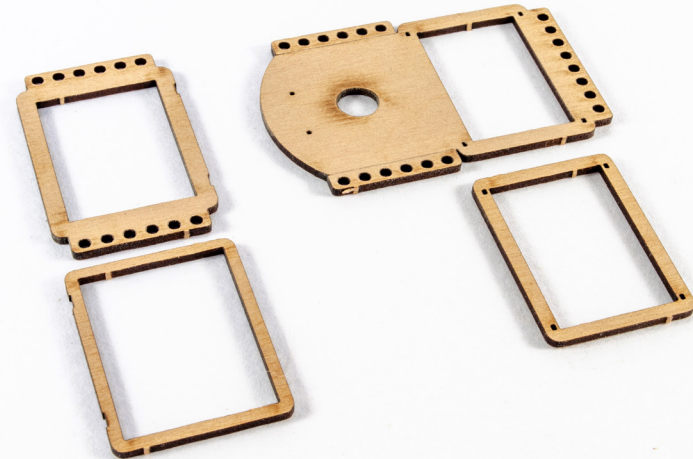

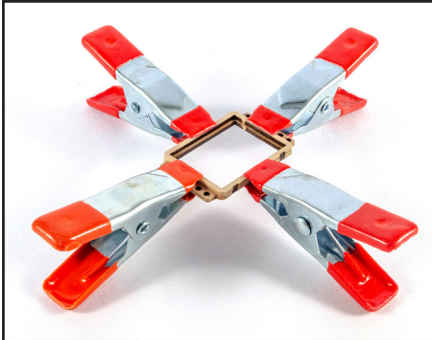

354. As before, remove the char and assemble the upper parts over the lower and clamp until set.



355. Your finished coamings will look like this.



356. Glue into position the last two coamings you assembled, as shown here and on plan. Make sure these are properly aligned (Use plank engravings too as guide) and also flat to the curved deck.



357. Now glue into position the first two coamings you made, as shown here. We recommend wood glue for this as it gives you time to align the parts and the glue sets reasonably quickly whilst you hold things in place.



358. AFT GUN DECK LADDER: Remove all parts for this from the 0.6mm wood sheet. These are in their own separate area so you can't get them mixed up.

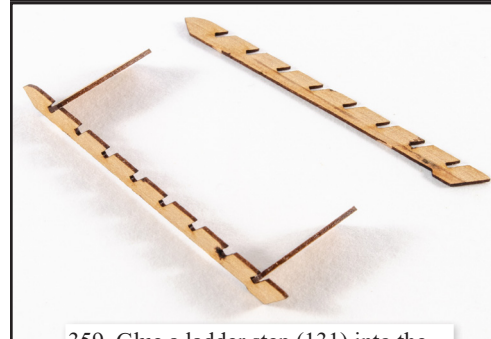

359. Glue a ladder step (131) into the top and bottom slots of a ladder side (128).

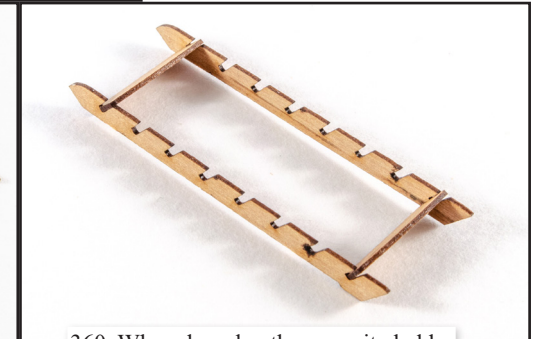

360. When dry, glue the opposite ladder side into position.



361. Now glue all the other steps into position.



362. Glue on the outer, engraved ladder sides.



363. Finished ladders.

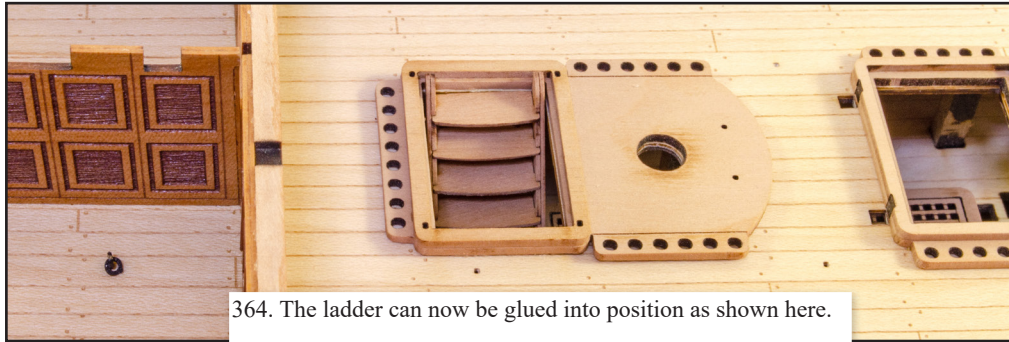

364. The ladder can now be glued into position as shown here.



365. MID GUN DECK LADDER:
Remove all parts for this from the 0.6mm wood sheet. These are in their own separate area so you can't get them mixed up.

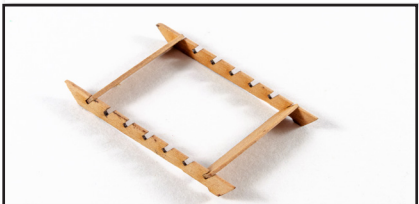

367. When dry, glue the opposite ladder side into position.

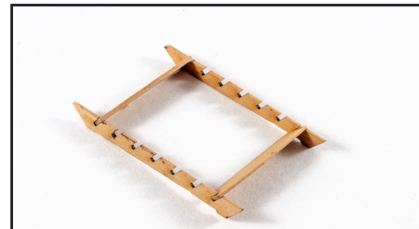

369. Your finished ladder will look like this.

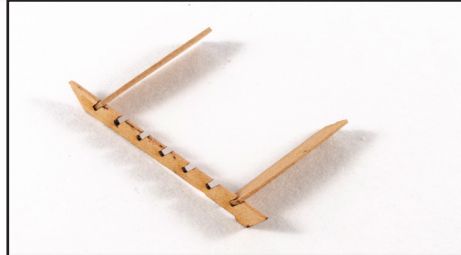

366. Glue a ladder step (123) into the top and bottom slots of a ladder side (120).



368. Glue all other steps into position followed by the engraved ladder outer sides (122).

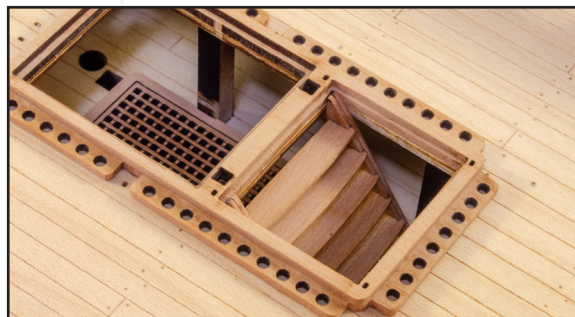

370. The ladder can now be glued into position as seen here.



371. From the 2mm wood sheet, remove the two Chain Pump Handle Stanchion – Aft (413).

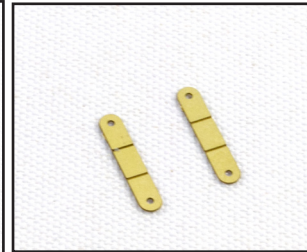

372. From the 0.2mm PE sheet, remove two Chain Pump Capping parts (PE-41).

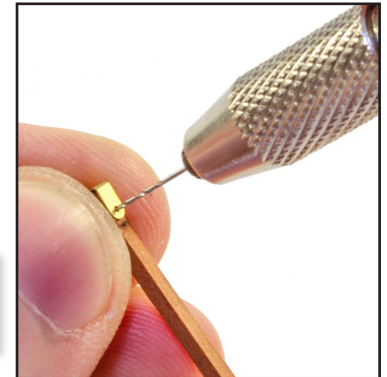

373. Bend the PE parts and sit on top of the stanchion. Now drill through the PE part into the stanchion (all the way through). Remove the PE part.

374. Glue the stanchions into place as seen here.



375. From the 3mm wood sheet, remove the Main Jeer Bitt Posts (465, 466). From the 2mm wood sheet, remove one of the Main Bitts Cross Beam (431).



376. Remove char (at least above deck level) and then glue the wooden parts as shown. From the 0.4mm PE sheet, remove two Chain Pump Handle Eyebolts (PE-143).

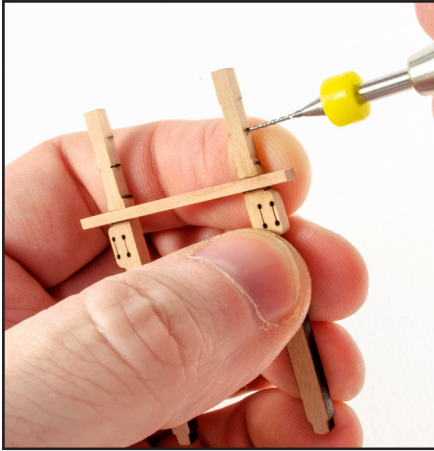

377. Use a 0.6mm drill bitt and drill through the assembly as shown. There is a laser engraved line to use as a guide. Drill through the middle of this, all the way through.



378. Insert the eyebolts on the inner sides of the assembly, and then paint black.

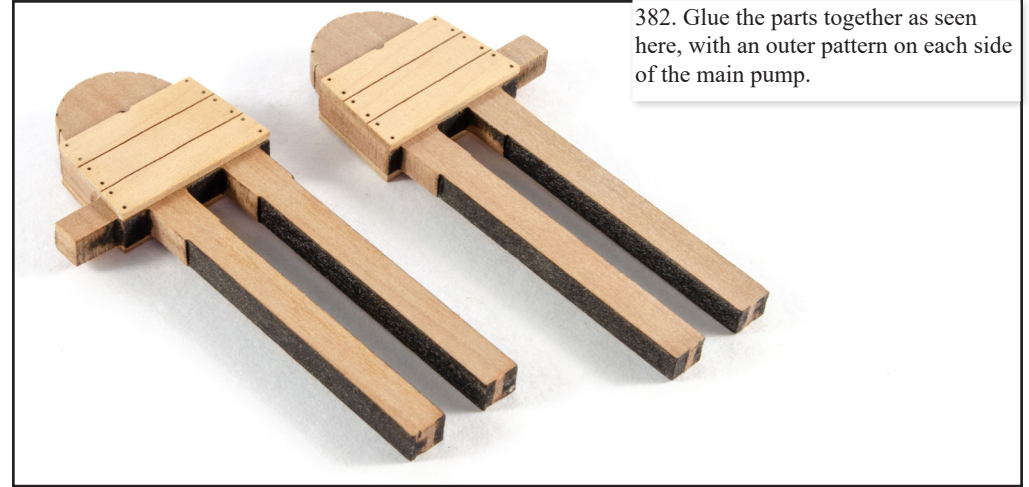

382. Glue the parts together as seen here, with an outer pattern on each side of the main pump.



379. The completed assembly will look like this.

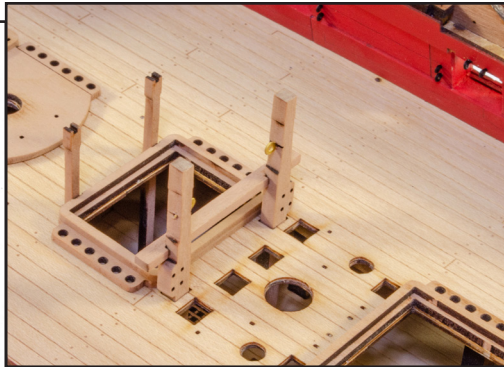

380. Glue the assembly into place as seen here, with the beam facing aft.

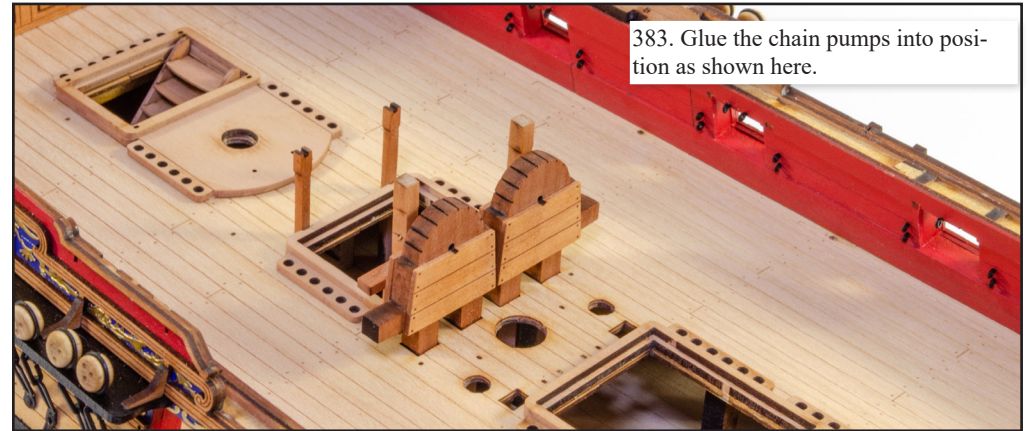

383. Glue the chain pumps into position as shown here.



381. From the 4mm wood sheet remove the two Chain Pump Main Patterns (476). From the 1mm wood sheet, remove the four Chain Pump Outer Patterns (199).



384. Whilst easy to do so, glue the remaining two-part eyebolts into position on the deck, as was done in the cabin areas. Also paint and glue eyebolts PE-106 into place. From the 1mm wood sheet, remove one Main Mast Base (202) and round the edges before gluing into position as shown.

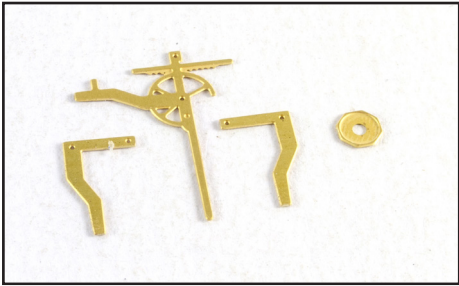

385. From the 0.4mm PE sheet, remove the Hand Pump Main Body parts – Left/Right (PE-145, PE-146), the Hand Pump Handle Side Brackets (PE-147), and the Hand Pump Caps (PE-148).



386. Use brass pins to locate a side bracket to each side of the main body. Use CA to glue.

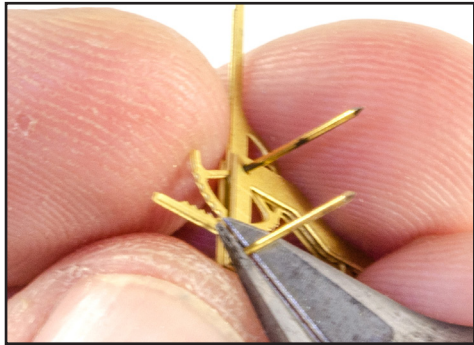

387. Snip off the excess brass pins.

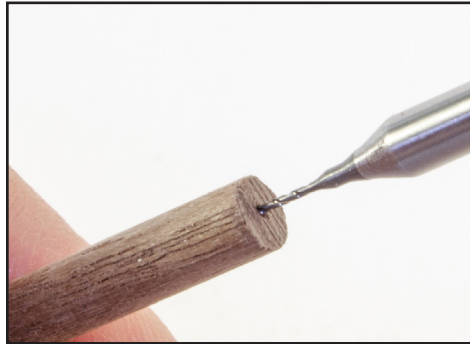

388. Cut a length of 4mm dowel 89mm long. Drill a 0.6mm hole in the top, several mm deep.

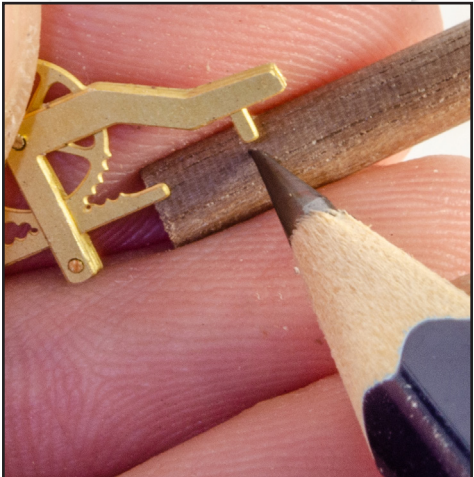

389. Sit the pump head over dowel as shown and mark the side brass 'pip' onto the dowel.

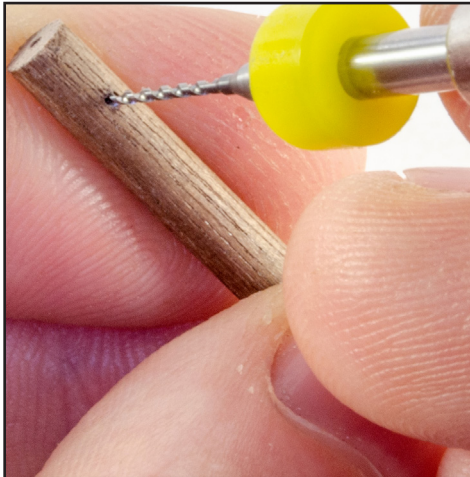

390. Drill the dowel with a 0.6mm drill bit at that point.

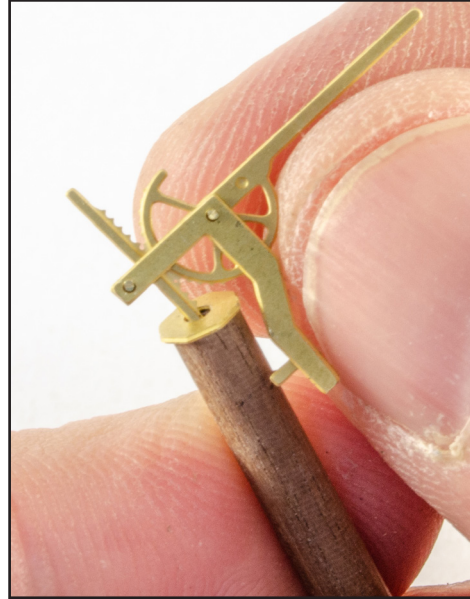

391. Glue the Hand Pump Cap onto the top of the dowel and push the main pump into it.



392. Now insert the side pip into the hole on the side of the dowel. Glue all assemblies.



393. Paint each pump in flat black. We used steel pigment powder to give a slightly metallic finish to the metal.



394. Glue the hand pumps into position as shown, in conjunction with the plan sheet.



395. From the 3mm wood sheet, remove the Main Topsail Sheet Bitts and Gallows (467), and from the 2mm wood sheet, remove the other Main Bitts Cross Beam (431). From the 0.6mm wood sheet, remove the two Panelling for Part 467 (90).

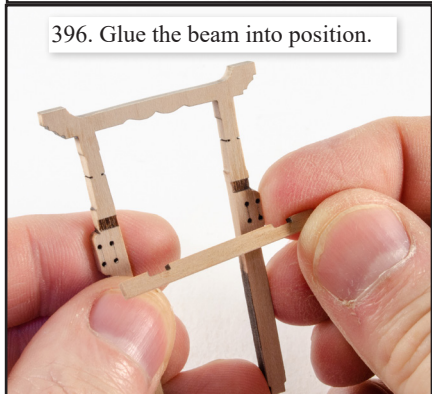

396. Glue the beam into position.



397. Now glue the two panelling parts into position on the front and back of the assembly.

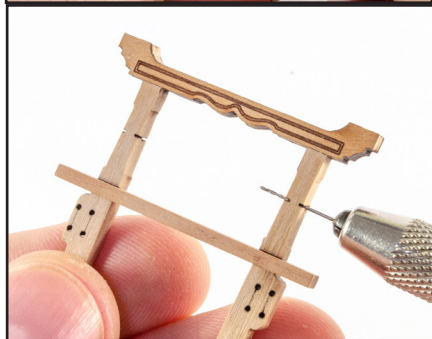

398. Use a 0.6mm drill to drill a hole through each side of the assembly, in the middle of the laser engraved line. The hole should go all the way through.



399. Remove two Chain Pump Handle Eyebolts (PE-146) from the 0.4mm PE sheet.



400. Glue the eyebolts into the assembly from the inside.



401. The completed assembly will look like this. You can paint the eyebolts in black.

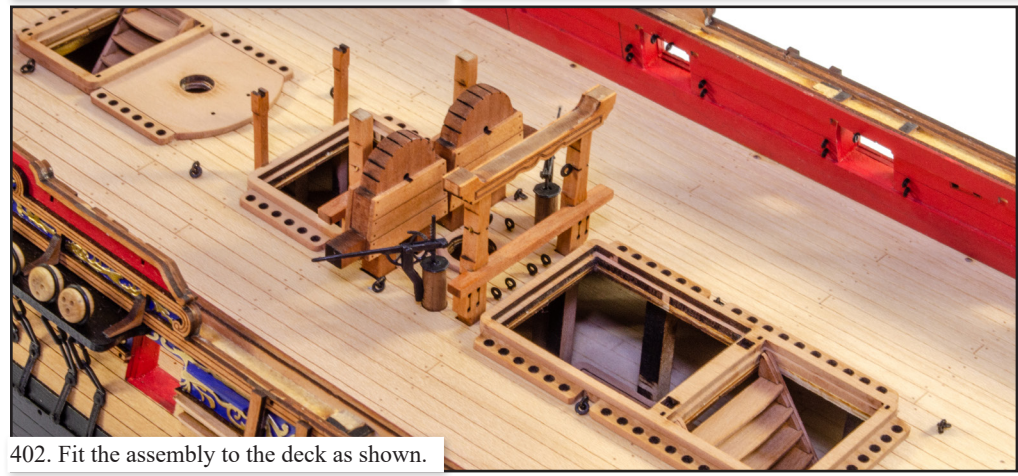

402. Fit the assembly to the deck as shown.



403. From the 2mm wood sheet, remove the two Chain Pump Handle Stanchions – Fore (412).

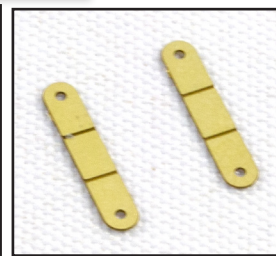

404. From the 0.2mm PE sheet, remove two Chain Pump Capping Parts (PE-41).

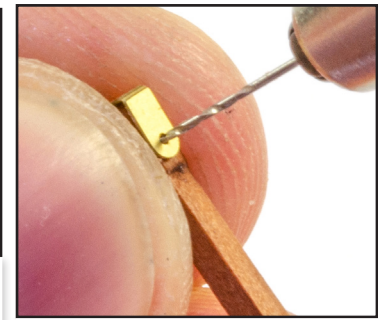

405. Bend the capping parts and sit over the stanchions. Use a 0.6mm drill to drill through these and straight through the stanchion. Remove the PE part.



406. Glue the stanchions into position as shown.

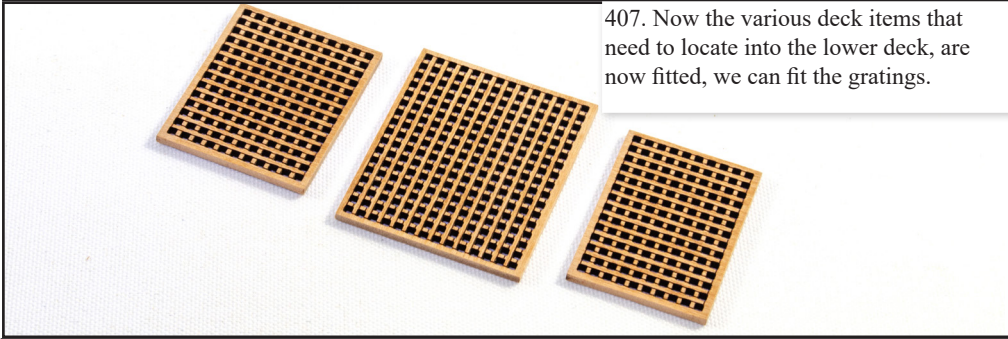

407. Now the various deck items that need to locate into the lower deck, are now fitted, we can fit the gratings.

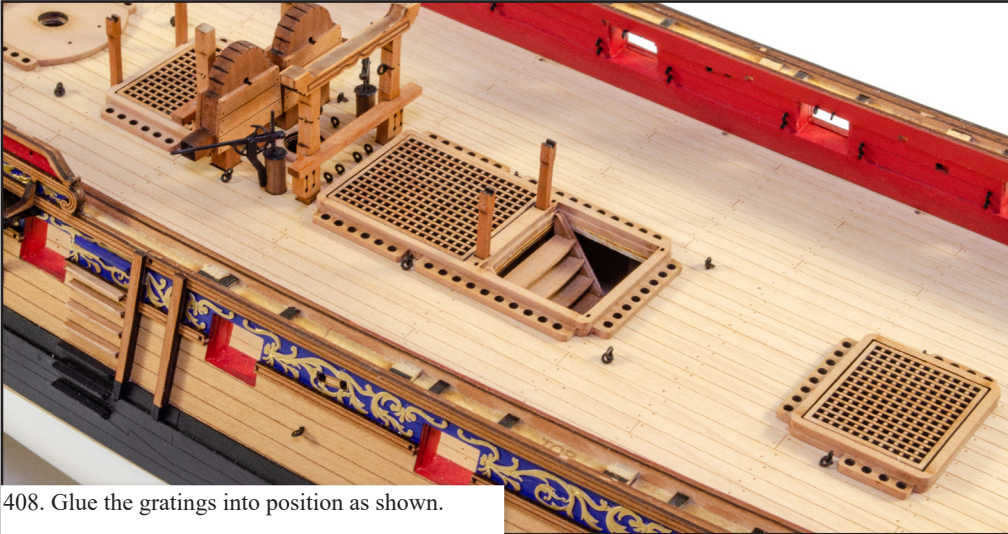

408. Glue the gratings into position as shown.

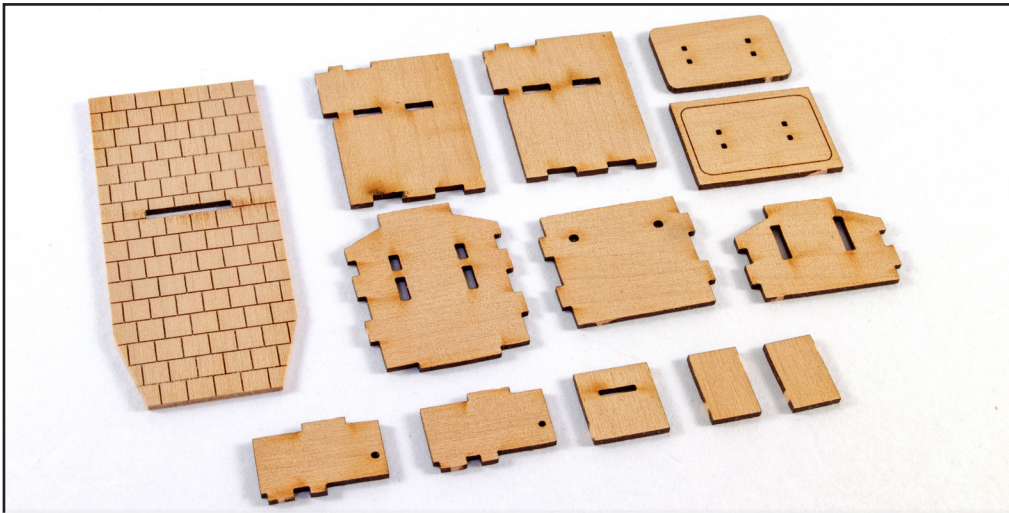

409. SHIP'S STOVE: There are quite a few parts for this, all to be found on the 1mm wood sheet. Remove parts 200, 204, 205, 206, 207, 208, 209, 210, 211 and 212.



410. Take part 204 and both 208 parts...

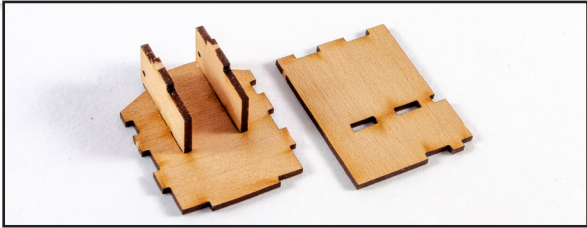

411....Glue them together like this. Now take one part 205.

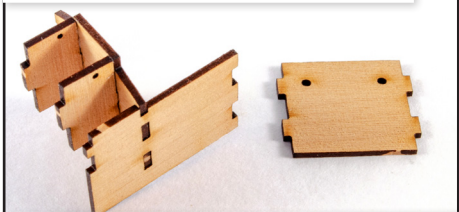

412. Glue 205 into position like this. Now take part 206...

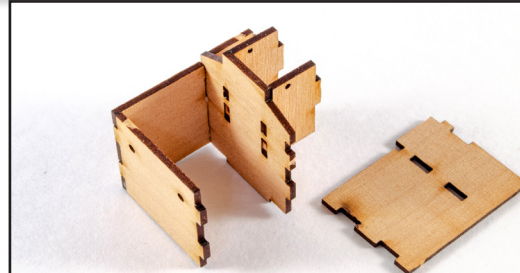

413. ...and glue into position as shown. Now take the other part 205...



414. ...and fit as thus. Now take part 209...

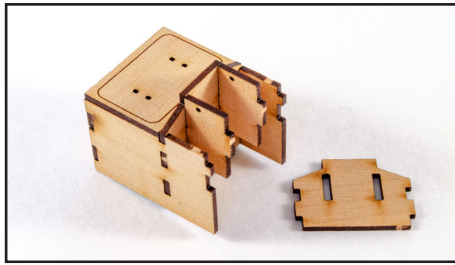

415. ...and fit onto the top rear of the stove as shown. Take part 207...



416. ...and fit like to the front of the stove. Part 210 now glues into the engraved area on the top rear of the stove.

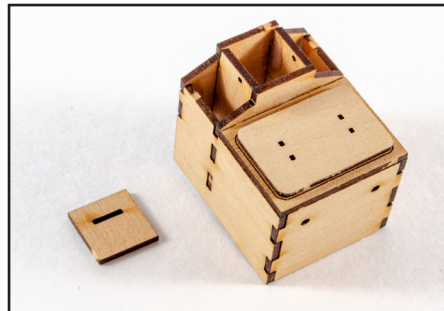

417. Part 211 is now needed and can be glued onto the top of the stove with the slot nearest the front edge of the stove.

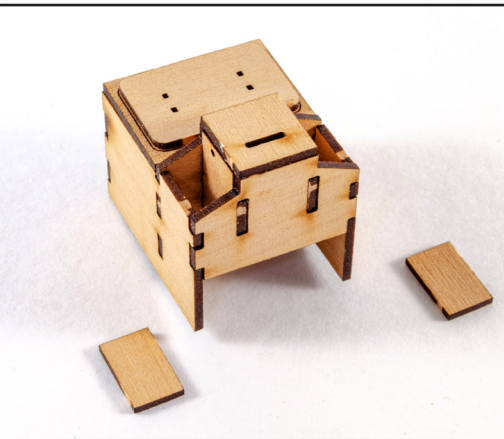

418. You will now need both parts 212.

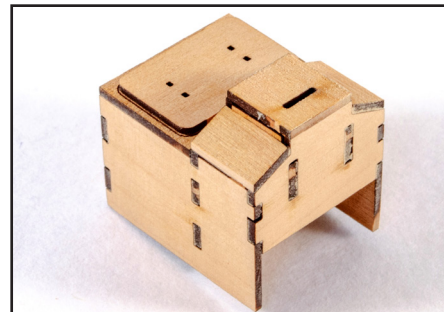

419. Slightly bevel one long edge and sit this up against the stove side like this. When happy the parts fit, glue them into position and when dry, sand off any overhang on the side of the stove.

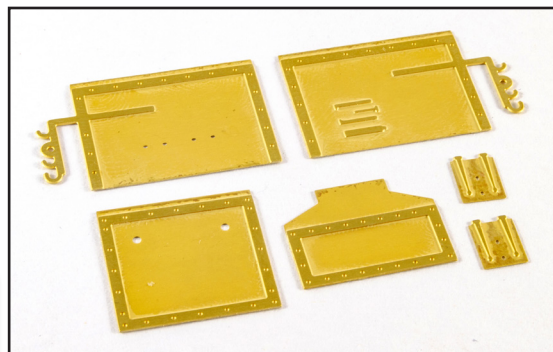

420. From the 0.4mm PE sheet, remove parts PE-69, PE-70, PE-71, PE-72, and both PE-75.



421. Using CA, glue PE-72 into position as shown.



422. Now glue PE-69 into position. Note the holes in this will align with the holes in the wood.

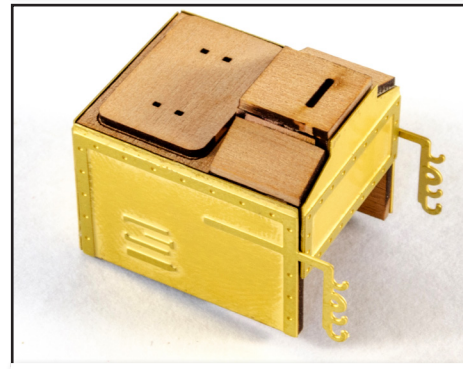

423. Take PE-70 and glue into position as shown.

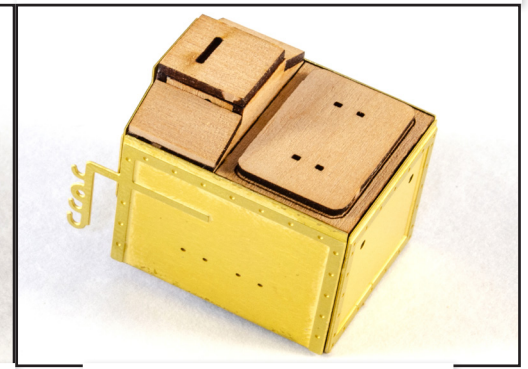

424. Take PE-71 and glue as shown.



425. Now take both PE-75 and glue into position as seen here. Note that the hinges on these parts are facing outwards.



426. From the 0.4mm PE sheet, remove parts PE-73 and PE-74. Glue into position as shown.



427. From the 0.4mm PE sheet, remove parts PE-76 and add these handles to the top rear of stove, as shown.



428. Add two more PE-76 to the small doors. You may need a small drill bit to open the holes a little to fit these.

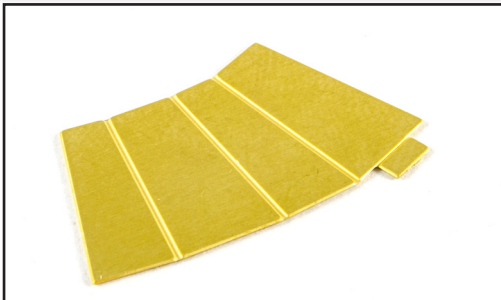

429. From the same PE sheet, remove PE-80.

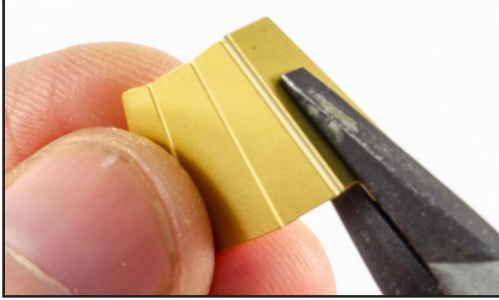

430. Use pliers or a PE bending tool to form the flue.



431. When complete, the flue will look like this. The small tab also bends down slightly, and you will need to test fit this to the stove to check the flue then sits flat.

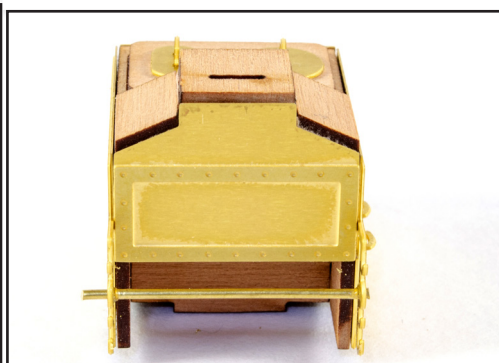

432. Cut a length of 1mm brass rod so it fits through the holes in the rotisserie and protrudes either side slightly. One side (shown) will need to protrude about 2mm.

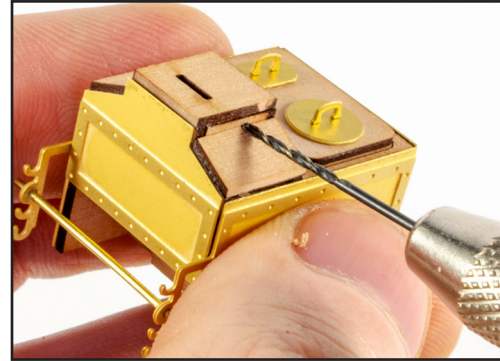

433. Use a 1mm drill to open up the holes in the stove flue support so the angled roof parts don't foul the opening. This is something you may need to do if those parts do obscure the holes.

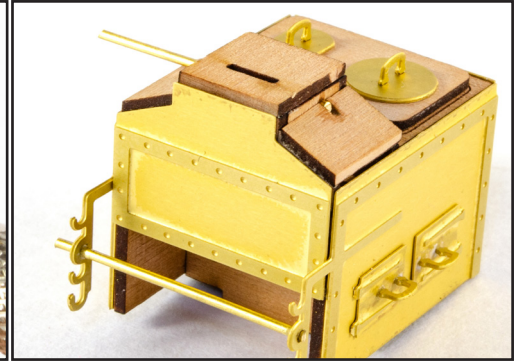

434. Cut another piece of 1mm brass rod so it protrudes over the same side as the one on the rotisserie. They should stick out at the same level as each other. The other side of this brass rod can be cut short just outside of the opposite hole.



435. Remove both PE-77 from the 0.4mm PE sheet and sit on the long sides of both brass rods. Don't glue yet.



436. Now remove the Chain Pulley PE-79 from the same sheet and glue into position as shown so it looks vertical from the front of the stove. Now glue those previous PE-77 up against the inside of the chain pulley.



437. Take both PE-78 and glue one on the outside of both ends of the chain pulley.

438. So far, this is how things will look.



439. Before you can later mount the flue, this small block will need to be used. This is part 211a on the 2mm wood sheet. Sand this part so it forms a wedge along its longest side.

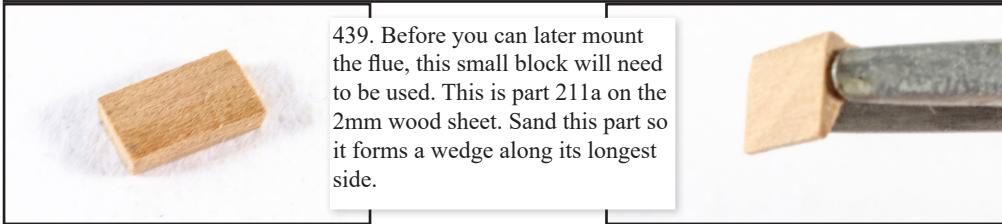

440. Glue into position on the rear of the flue mounting plate. This extends that area, so the flue won't overhang.



441. With the flue sat temporarily in position, this is how it looks.

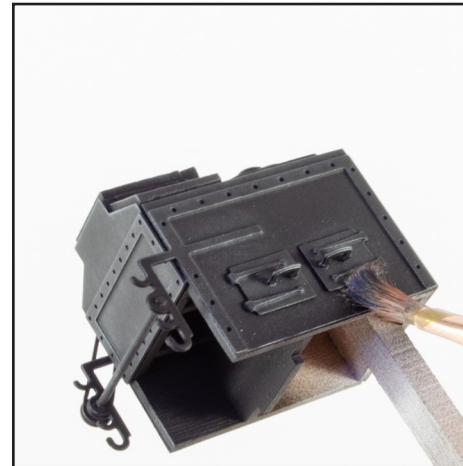

442. Prime the stove and then paint in matt black. We find that adding some steel pigment powder with a dry brush, helps to make it look quite realistic.



443. To paint the bricks, use a brick-coloured paint and then seal this with an acrylic varnish. We then used a panel-line enamel wash (light grey) and flowed it into the mortar areas. When dry, the excess is removed with a cotton bud. At this stage, DO NOT glue the stove to the bricks.

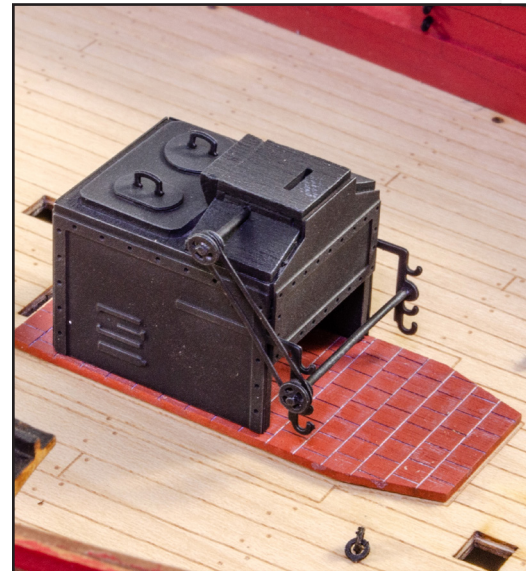

444. First, glue the brick part into position over the engraved deck position. When dry, glue the stove into the slot on the bricks part, with the front of the stove facing towards the bow as shown.



445. From the 3mm wood sheet, remove the Riding Bitts Cross Beam (462). From the 4mm wood sheet, remove both of the Aft Riding Bitts Posts (477).

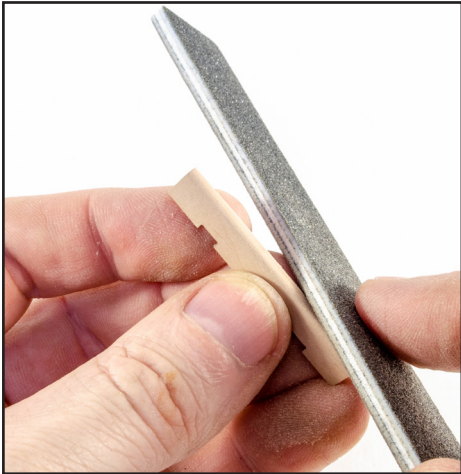

446. Remove char from the parts and then add rounded edges to the side of the beam that faces aft.



448. Glue this into position behind the stove, as seen here.

450. Glue Galley Door Panel 65 to part 68. Now glue the door panels 67 and 66 together. This will create two doors with external engravings on both sides.



447. The finished assembly will look like this.

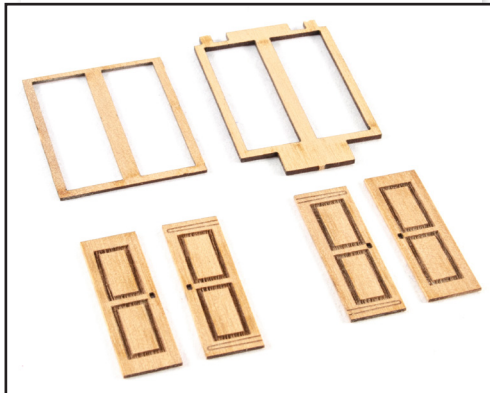

449. From the 0.6mm wood sheet, remove the Galley Door Frame – Outer (101), and the Galley Door Panels (65, 66, 67, 68). From the 1mm wood sheet, remove the Galley Door Frame Inner Pattern (180).

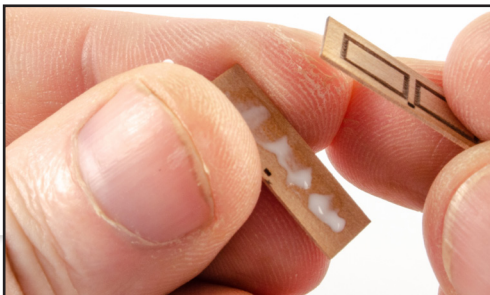

451. This is what you will now have.



453. Remove the Galley Door Handles (PE-113) from the 0.4mm PE sheet and assemble in the same way as the deck eyebolts. Now glue these into the galley doors.



455. You can pose these in an open position so you can see the stove from the deck. Paint the handles and hinges in black.

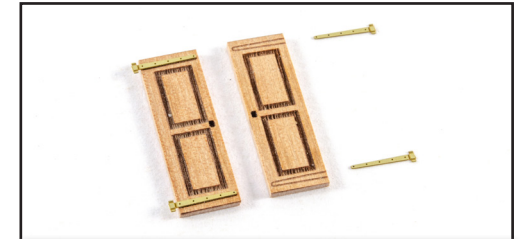

452. From the 0.2mm PEE sheet, remove the Galley Door Hinges (PE-162) and glue into position over the engraved door marks so the small hinge tab protrudes at the outside edge.



454. Glue the doors to the frame.



456. Glue the assembly into position as shown here.

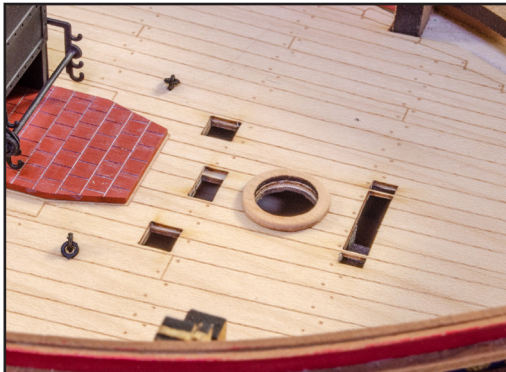

457. Remove a Fore Mast Base (202) from the 1mm wood sheet and gently round one edge of this. Glue into place as shown.



458. From the 4mm wood sheet, remove the Fore Riding Bitts Posts (478) and the For Riding Bitts Post Supports – Left/Right (479, 480).



459. Remove the char and assemble as shown.



460. Glue into position as seen here, making sure the post supports are on the inside of the posts.



461. From the 3mm wood sheet, remove the Bow-sprit Support (461).



462. Glue into position as shown.

463. LOWER CAPSTAN: From the 1mm wood sheet, remove ONE part 251, 252 and TWO part 250. Also remove part 253. From the 2mm wood sheet, remove FIVE Capstan Whelps (437). Cut a length of 6mm dowel, 60mm long.



464. Glue the five capstan whelps (437), onto the two Capstan Chocks (250). You can temporarily slide the down into the chocks to help you get the shape correct.



465. Glue the Capstan Lower Drum Head (251) into place on top of your assembly. Again, the dowel will help you position this.



466. Now glue the Capstan Drum Head for Bars (252) into position.



467. Glue the Capstan Upper Drum Head – Gun Deck (253) on top of your assembly as shown.



468. Lastly, glue the Capstan Top Drum Head – Gun Deck (254) in place. You can now withdraw the dowel.



469. Your finished capstan will look like this. You can either leave this in natural wood or paint it red as per the inner bulwarks.



470. Drop the dowel into position as shown.

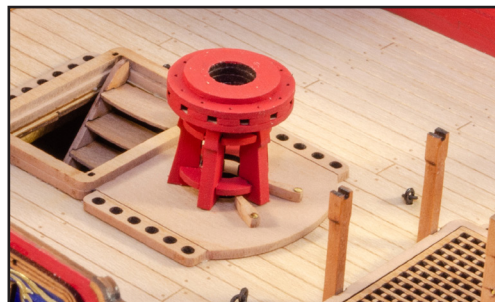

471. Glue the Capstan into position on the coaming. The dowel can now be either removed or glued into position. Another length of dowel will be inserted once the upper capstan is fitted, which will build this up to the correct height.

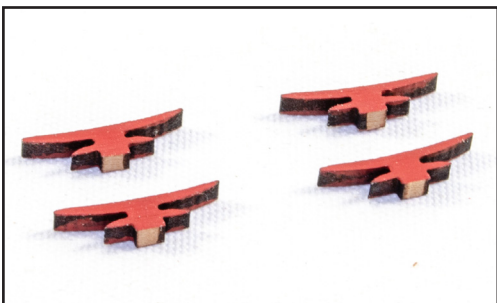

472. From the 2mm wood sheet, remove four Gun Deck Bulwark Cleats (430). You'll find it easier to paint these red whilst on the sheet, and then just paint the edges red when removed.



473. Glue these into position as shown on here and on the plans.

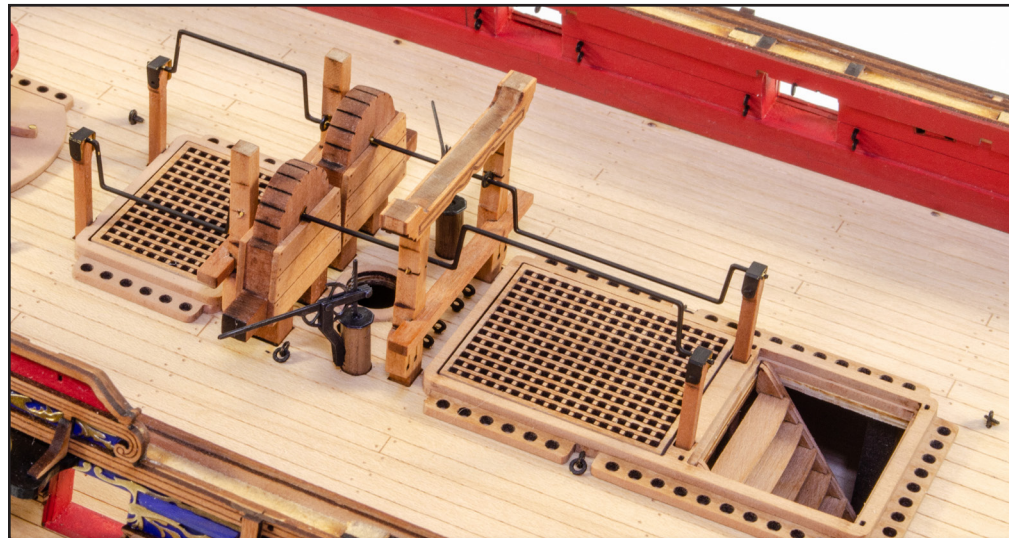

474. From the 0.6mm PE sheet, remove the Chain Pump Handle Bars – Fore/Aft (PE-149, PE-150). Using your plan as reference, glue them into position as seen here. We have set port and starboard handles in opposite positions to each other for variety. Paint these black. Where the handles sit on the stanchions, fit the Chain Pump Capping parts you bent into shape earlier, and secure them with pins. Paint the capping in black.



475. From the 0.4mm PE sheet, remove eight Ladderway Stanchions (PE-105)

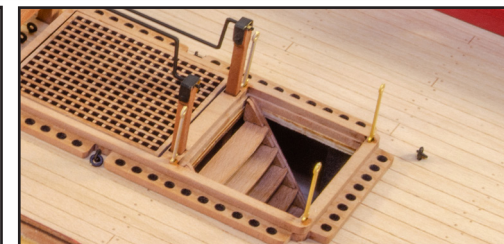

476. Glue into position as shown on plan. NOTE: The aft stanchions will fit at 90 degrees to what is shown here after parts were changed. Paint the stanchions in black.

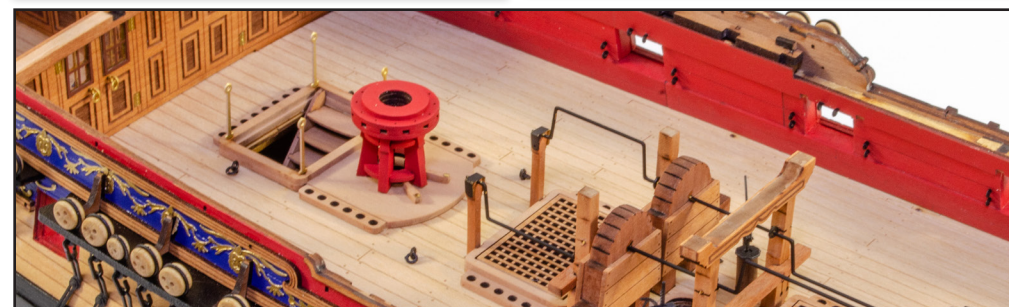

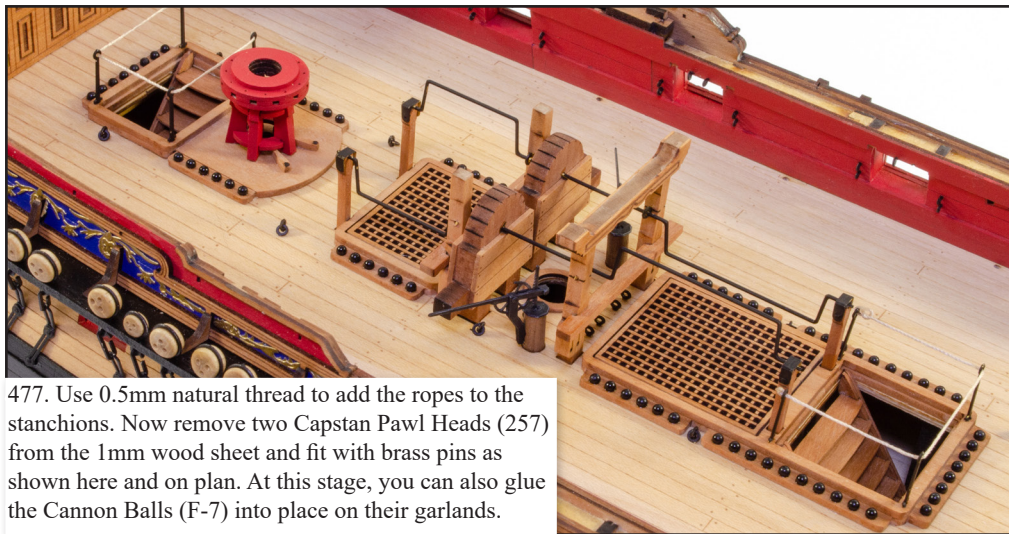

477. Use 0.5mm natural thread to add the ropes to the stanchions. Now remove two Capstan Pawl Heads (257) from the 1mm wood sheet and fit with brass pins as shown here and on plan. At this stage, you can also glue the Cannon Balls (F-7) into place on their garlands.



478. From the 3mm wood sheet, remove the Rid-bitts Knees (464).



479. From the 1.5mm wood sheet, remove the parts for the cannon carriages. These are grouped together and numbered 366, 367, 368, 369, 370, 371 and 372. You will need to build 20 guns.

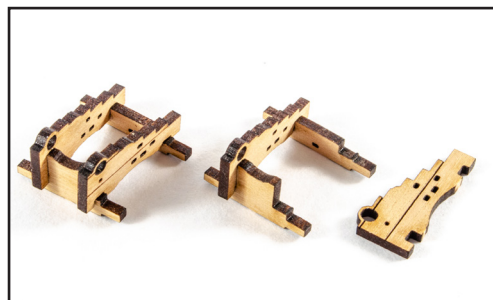

480. Glue a carriage side to the axles as shown. Note the deeper axle is the front part. Leave one side off the carriage as you'll later need to slot in the gun, but use it to make sure the carriage parts are aligned.

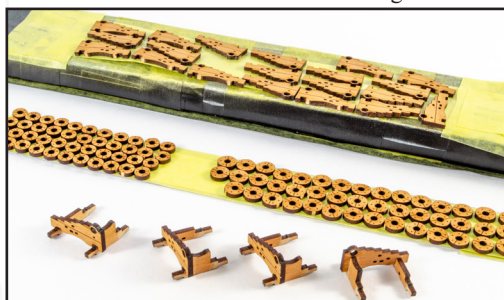

481. The wheels are now prepped for varnish. Note there are two sizes, and the larger pair are the front wheels. The carriages are also prepped for painting, with an initial coat of varnish to seal the wood.

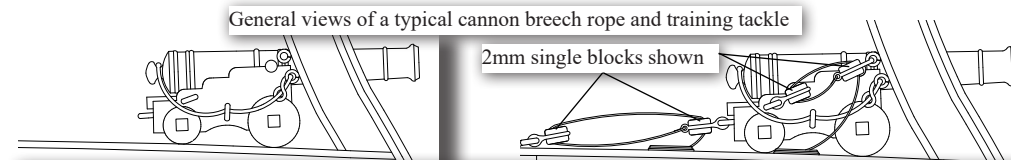

Optional - Above left - Rigging the cannon with breech rope only. (Blocks and rope to be purchased separately) Above right - Rigging the cannon with breech rope and training tackle. The blocks are all 2mm single blocks (Or 2mm single and 2.5mm double - anything larger would look too over scale), and the rope would be 0.1mm, with the breech rope being 0.5 or 0.75mm natural. If you choose to rig with a single and double block, the single is attached to the eyebolt on the carriage, with the start of the rope tackle starting from the single block, and the double attached to the eyebolt located on the bulwarks.

482. (Right) Tamiya Flat Red XF-7 is first air-brushed over the carriages and then a couple of thin coats of Vallejo Flat Red are hand painted over them to get the colour I need.

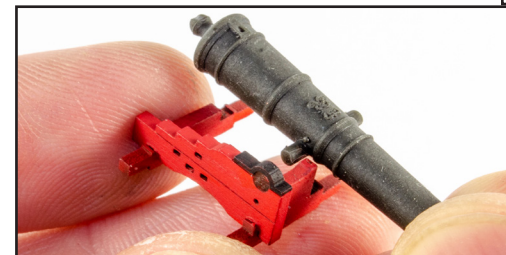

483. After painting the cap squares in black and removing paint from connecting surfaces, the gun is slid into the cap square. Make sure the George III emblem faces UPWARDS.



484. Glue the other carriage side into place.

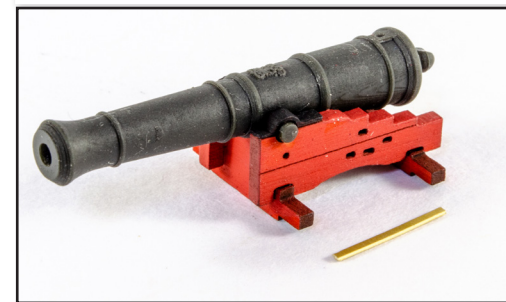

485. From the 0.4mm PE sheet, remove the Cannon Carriage Cross Bars (PE-107)

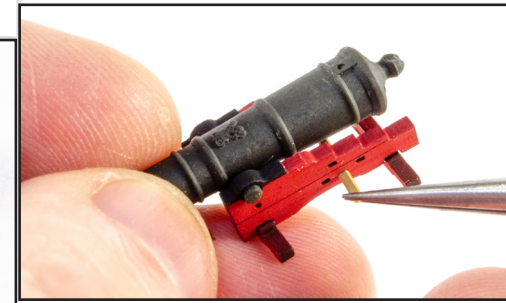

486. Fit and glue between the carriage sides, through the lower middle slot, as shown. You can paint these black before or after fitting.

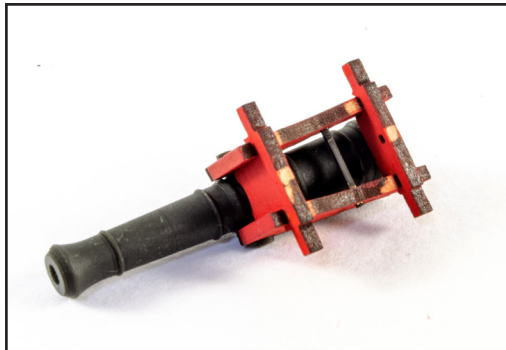

487. Here you can see the cross bar in position.

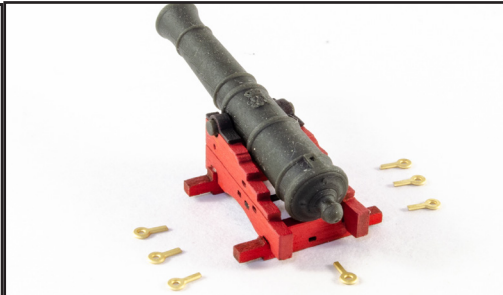

488. From the 0.4mm PE sheet, remove the Cannon Eyebolts (PE-81). You can paint these before assembly, and you will need seven per carriage.



489. Fit the eyebolts as shown. Now take the Carriage Quoin you removed from the wood sheet...

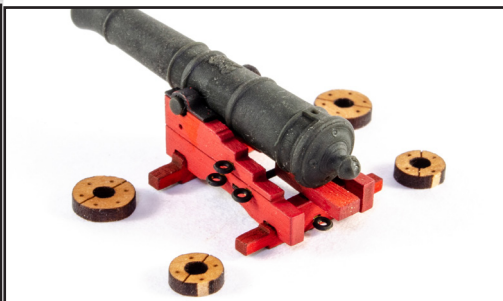

490. ...and glue as shown. This will sit against the cross bar at the front edge. Now take two large and two small wheels. Fit the large to the front axle and the small to the rear axle. NOTE: We suggest the sheet connecting tag sits on the bottom of the wheel if you opt to leave the char on the edges.

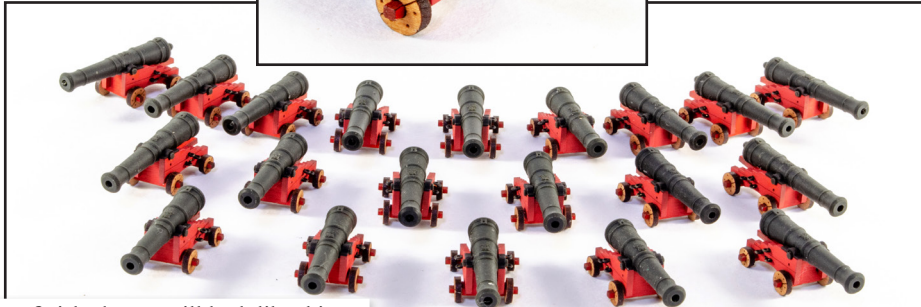

491. Your finished guns will look like this.

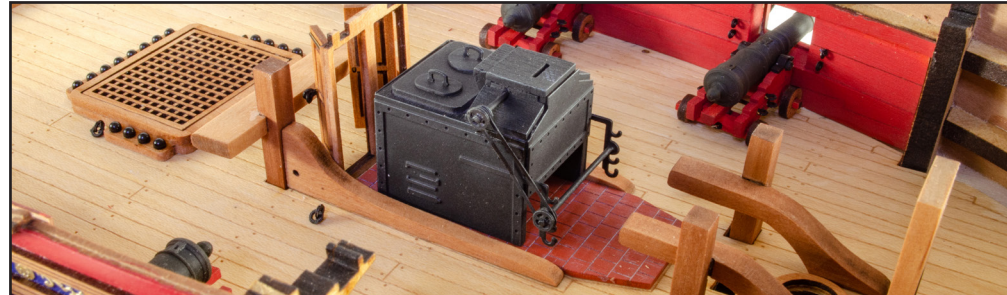

492. Glue the Riding Bitt Knees into position at either side of the stove (in the engraved area) and up against the aft riding bitts posts. You will need to very slightly bevel the underside of these parts to cater to curve in deck.



493. Now it's the turn of the cannon to be glued into position. Make sure each gun is just a little back from the bulwark and glue to the gun is central in the opening, and also at 90 degrees to the bulwarks. That of course means that the guns will have a gentle sweeping curve when fitted.

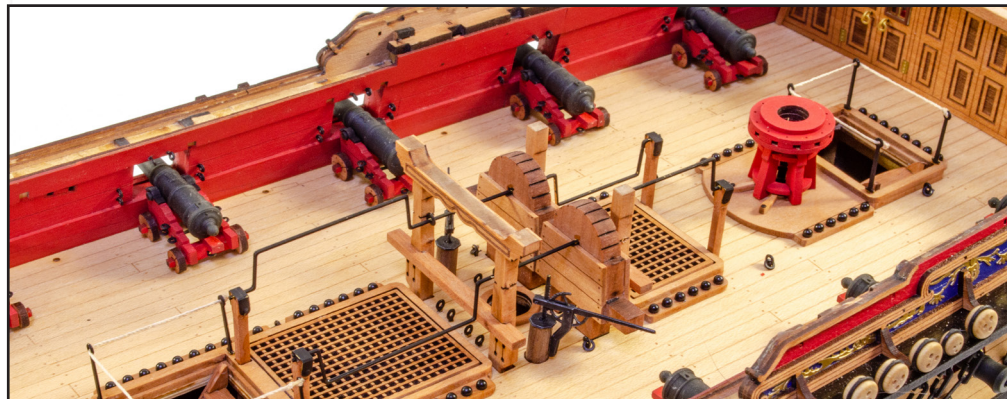

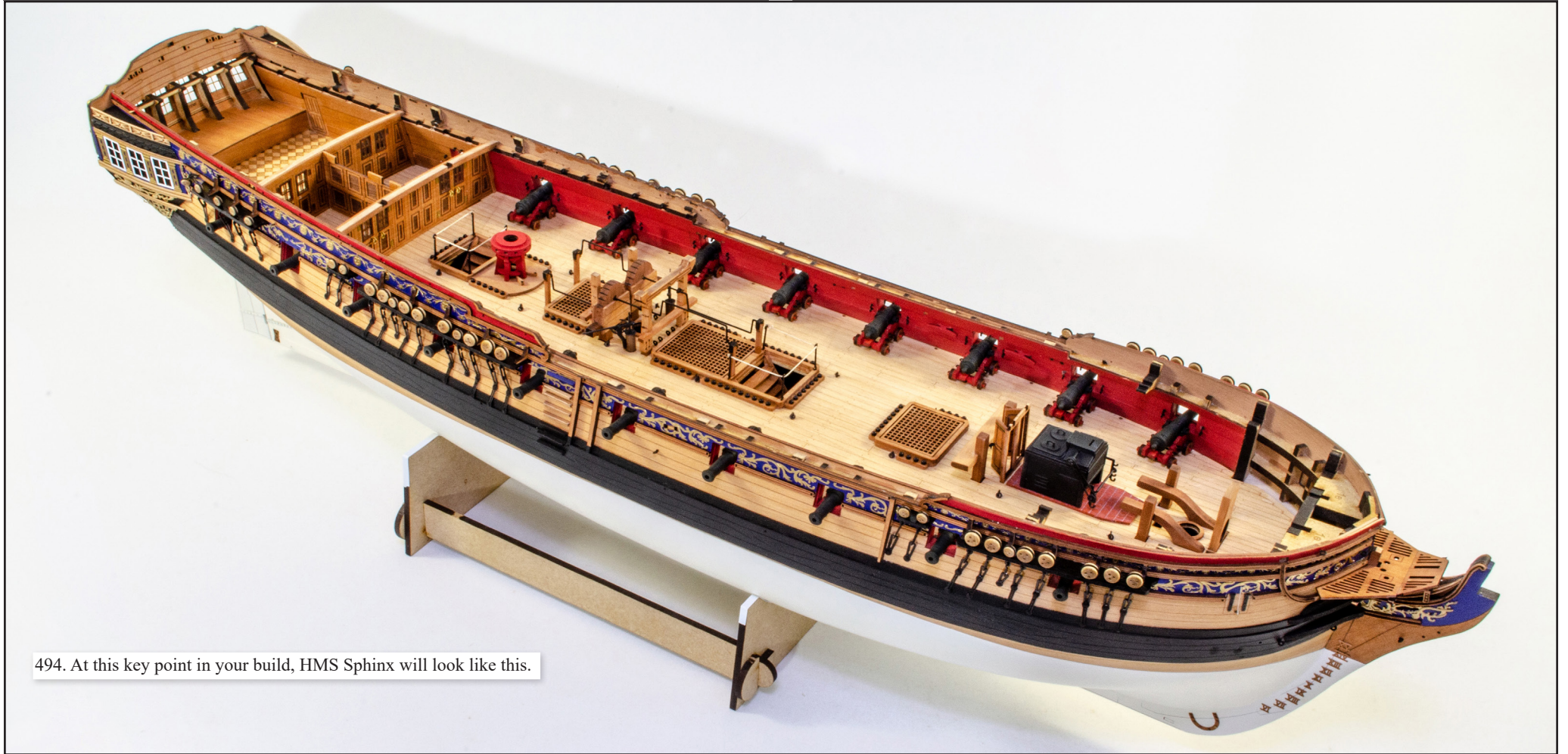

494. At this key point in your build, HMS Sphinx will look like this.

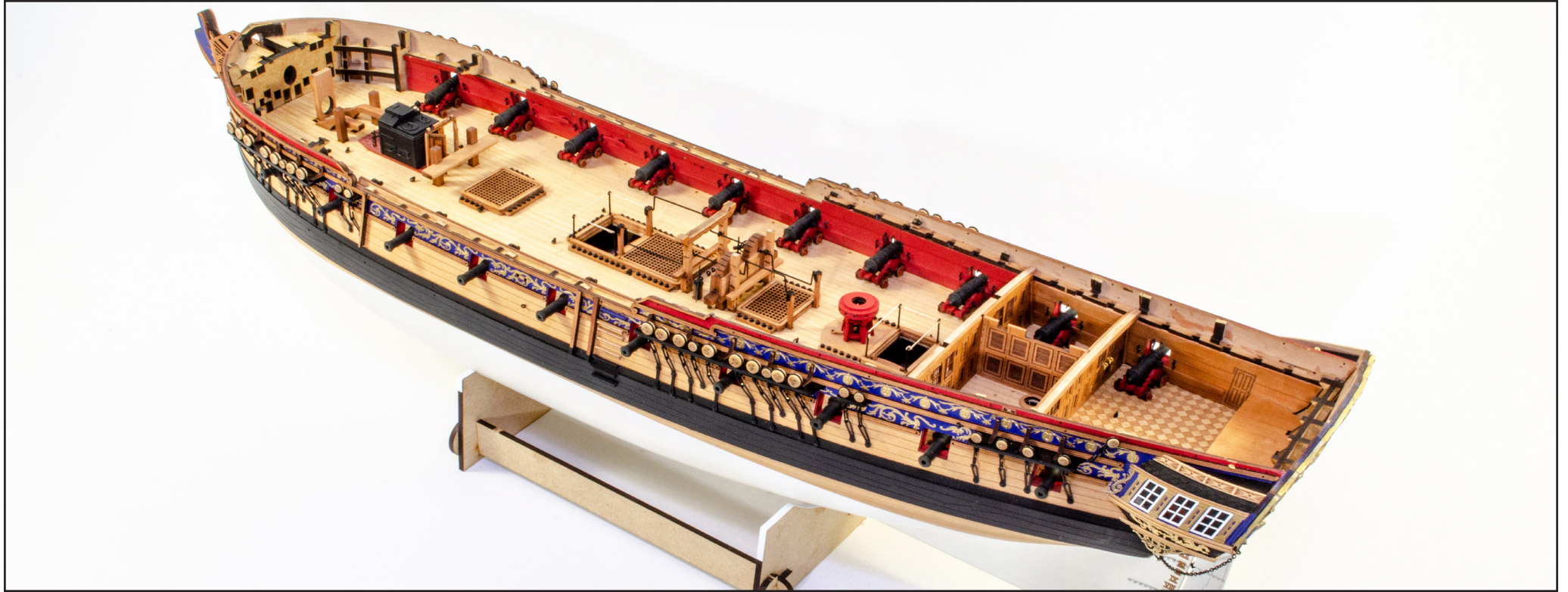



495. Glue Deck Beam 'A' into position. There are engraved marks on both the deck beam and location point which shows where each fit. Beam 'A' will also sit atop the two chain pump handle stanchions as shown.



496. OPTIONAL: We have included a series of Quarterdeck Hanging Knees (392) which can be found on the 1.5mm wood sheet. It's up to you whether you want to install these for extra realism. If you do, then fit each pair as you fit each subsequent deck beam as this is the easiest way of installing them. The positions of these are shown on your plans. Some will need to be painted red and some left in natural wood.



497. Here you see the knee installed for deck beam 'A'.

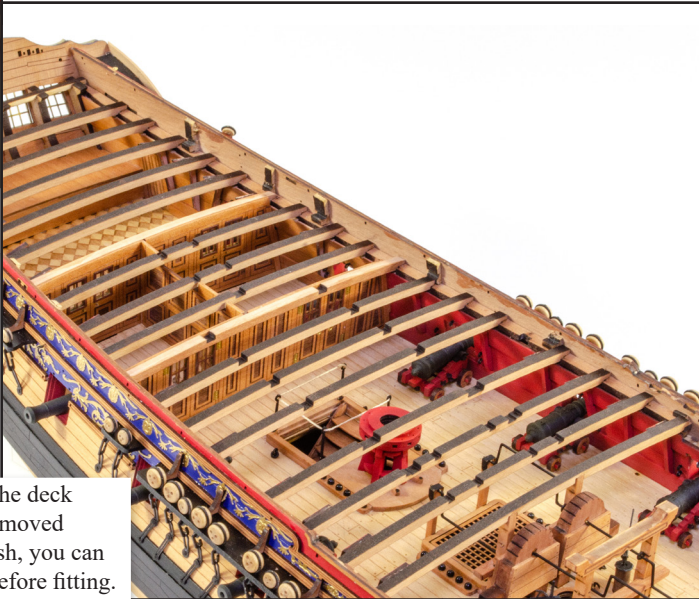

498. Now fit the remainder of the deck beams that you have already removed from your part sheet. If you wish, you can remove the char from the top before fitting.

499. Here is another picture of the quarterdeck beams in place with the optional hanging knees.

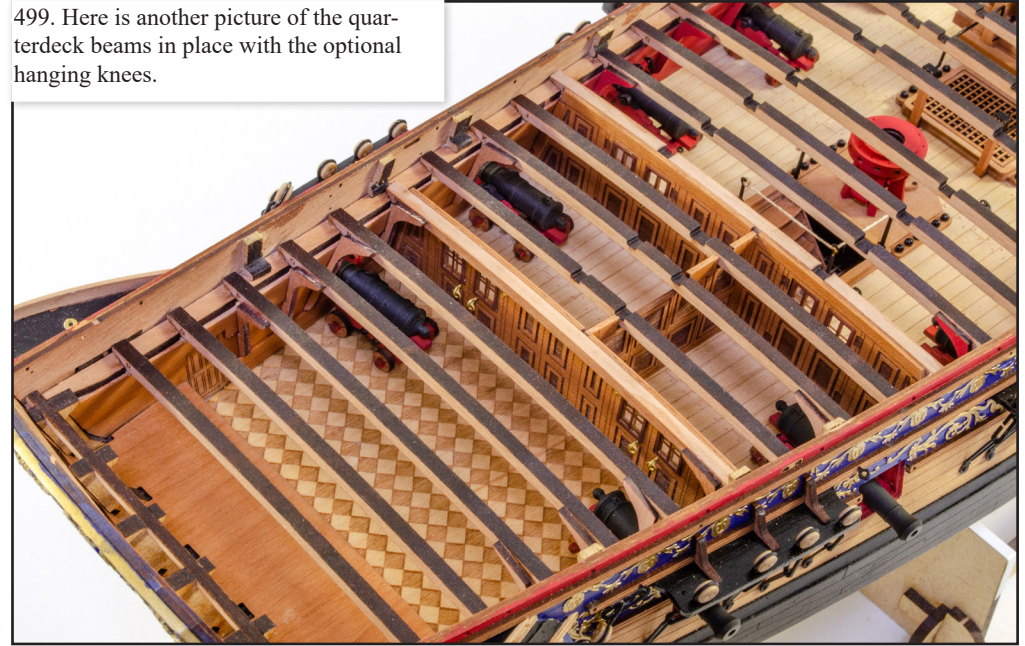

500. From the 3mm wood sheet, remove the Quarterdeck Beam Carlings (456, 457). From the 2mm wood sheet, remove the two Quarterdeck Carling Beams – Mizzen Mast (414), and the four Quarterdeck Carling Beams – Coaming (414a). Note the mizzen mast parts have an 'F' engraved on them. That means 'forward'. You will also need the quarterdeck deck beam parts 'E' and two more painted hanging knees.



501. Glue all parts into position as seen here and on plan. Allow time to dry. Note that the parts 456 have lettering on them. Install these so the text faces away from the bulwarks.



502. From the 0.8mm wood sheet, remove the Quarterdeck Beam Moulding (275).



503. Glue this into position on the front of the first deck beam 'A' so that it's flush with the upper edge of it.

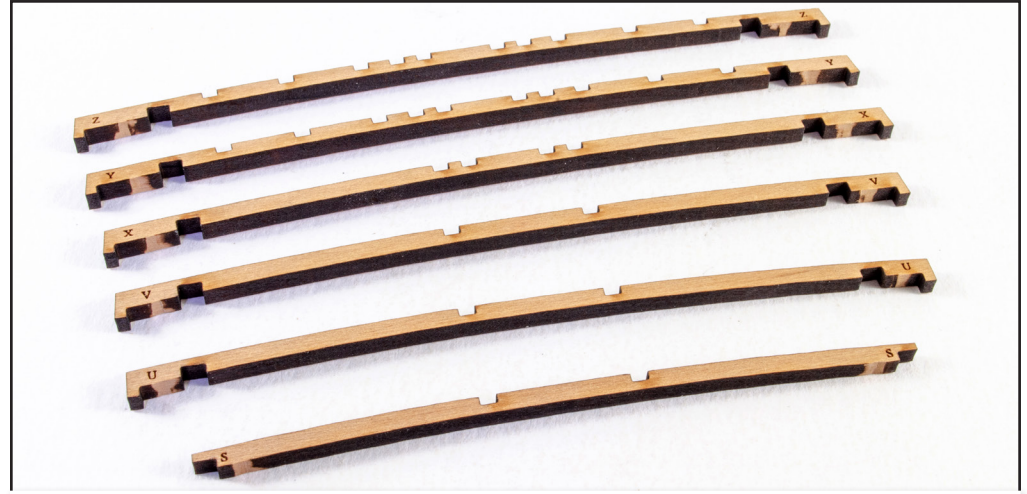

504. Now we can look at the forecastle deck frames. From the 3mm wood sheet, remove Forecastle Deck Beams (460S, 460U, 460V, 460X, 460Y, and 460Z).

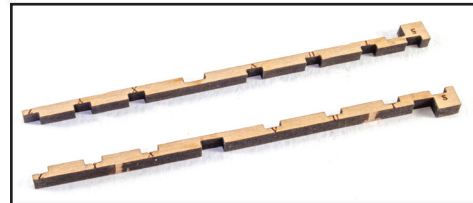

505. From the 3mm sheet, remove the Forecastle Beam Carlings (459).

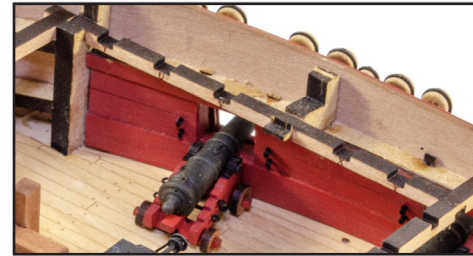

506. Glue the Forecastle Beam Carlings into position across the MDF bulkhead beams you used for the jig. Note: You WILL need to file the bottom on the MDF slots to an angle that slopes aft. This is because these carlings should run more or less parallel to the gundeck below them. You can check if you've filed the correct angle by test-fitting deck beam 'Z', as each end of this should rest on the bulwark shoulders. If it does, glue the carlings into position.

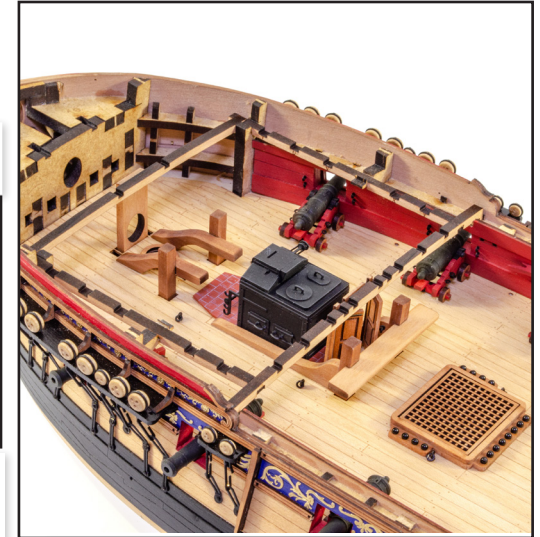

507. Now glue deck beam 'Z' and 'S' into position on the carlings, creating this box-like structure.

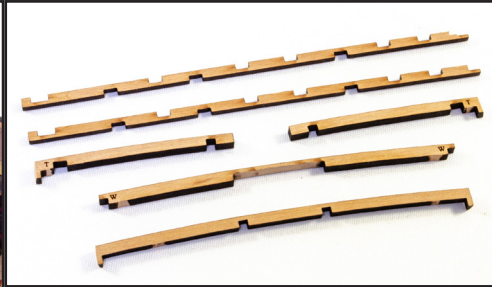

509. From the 3mm wood sheet, remove the two forecastle beams 'T' (460T), forecastle beam 'W' (460W), forecastle beam 'RF' (460RF). From the 2mm wood, remove the two Forecastle Longitudinal Deck Beams (411).

508. Before we go any further, we need to fit the anchor cable into position. On our model, the cable will terminate in a knot directly behind the bulkhead, as shown. Use the inner hawse hole for this, and the inner pair of bulkhead holes. This is quite easy to thread, and you can also use tweezers through the bowsprit channel to make sure they run through. Seal the knot with some PVA or CA. With the anchor cable in position, now glue in the forecastle deck beams into their respective slots. Note: All slots are numbered for ease of location.

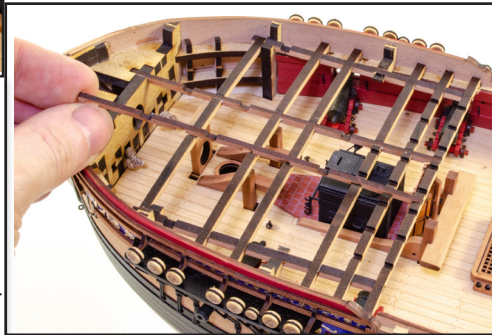

510. Glue the longitudinal deck beams as shown here.



511. To fit deck beam 'RF', you will need to bevel the ends of the beam to fit within the curved bow.

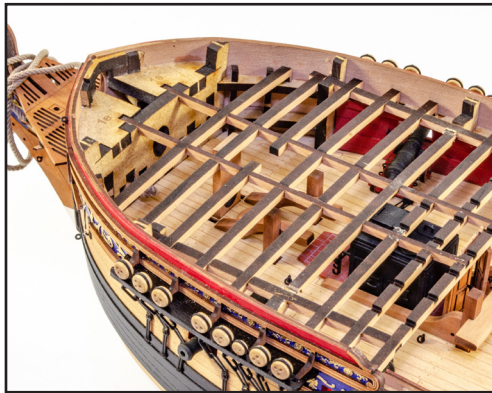

512. Glue 'RF' into position the foremost slots in the longitudinal beams.



513. From the 2mm wood sheet, remove the SIX Forecastle Carling Beams (415), and the TWO Forecastle Carling Beams (425).



514. Fit them as shown here and on the plan.



515. From the 0.8mm wood sheet, remove the Forecastle Deck Beam Moulding (276).



516. Glue this in place centrally on forecastle deck beam 'Z', so it's flush with the top of the beam. You may need to trim each end of this to fit your specific hull.



518. We can now prepare the bowsprit opening in the bow, to accept the 8mm dowel. To do this, take a drill bit around 6.5mm - 7.00mm and wrap some medium sandpaper around the shank end. Push this into the bow opening and turn the drill bit by hand as you go, opening up the hole slightly. Continue with the drill when you reach the bowsprit support, so you also elongate this too. Do this until you can slot an 8mm dowel through this and into the bowsprit support which is plugged into the gun deck.

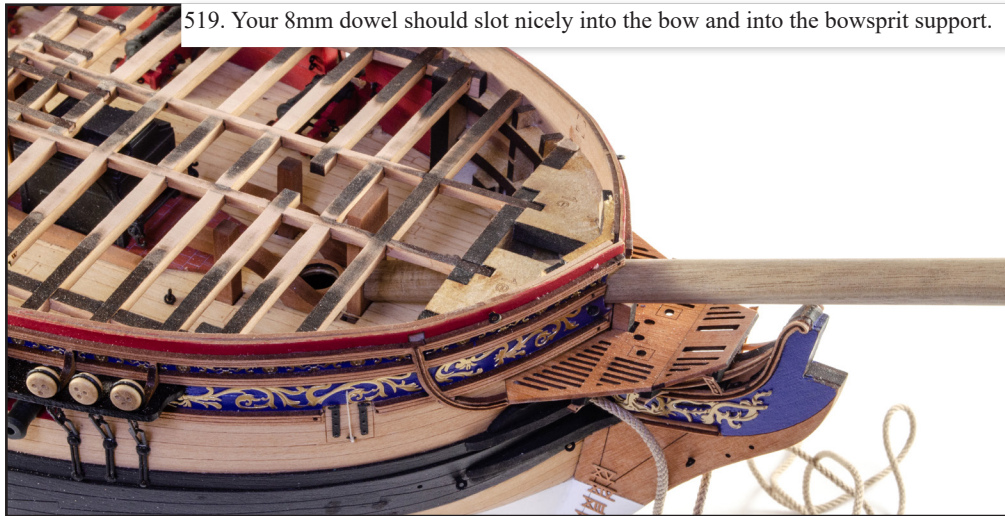

519. Your 8mm dowel should slot nicely into the bow and into the bowsprit support.



520. From the 0.8mm veneer sheet, remove the Forecastle Deck Pattern. Test fit this to your model, and if necessary, sand the edges to the part sits properly and flat across the deck beams.

521. OPTIONAL: This part is the Forecastle Deck Pattern (50) found on the 0.8mm ply sheet. If you wish to plank your own deck instead of using the engraved maple deck supplied, you can then use this ply part to plank upon. If you wish to use this, you can now glue in position. NOTE: We do not supply deck planking strips for this option.



522. From the 3mm wood sheet, remove the Fore Jeer Bitts (463) and then also remove the char.



523. Slot and glue the Fore Jeer Bitts through the hole in the gun deck and down into the lower deck where it will plug. The engraved slots for the beam should face aft. NOTE: Early batches of Sphinx have a slot in the gun deck that will need opening a little wider so that it's the same width as the maple deck.

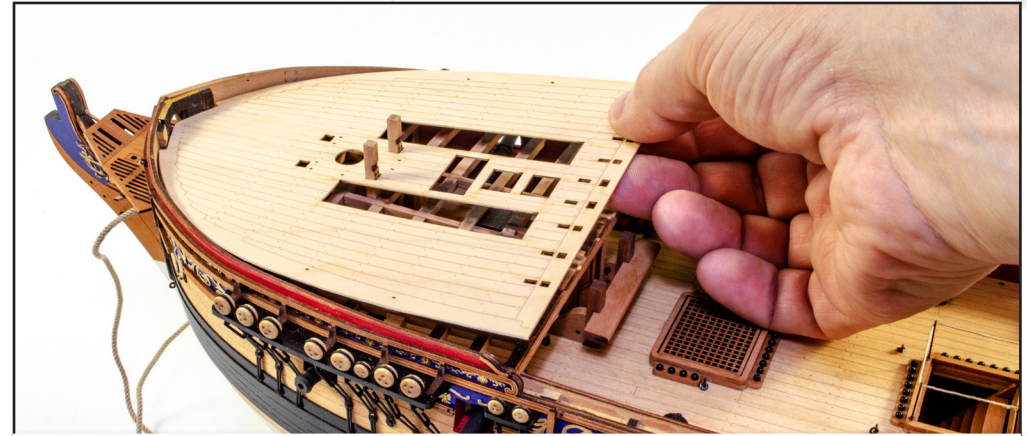

524. Glue the deck into position, slotting it over the Fore Jeer Bitts, as shown. You can also install the 8mm dowel to help you fully locate the deck. Use small clamps around the edges of the decks to hold it down into position.

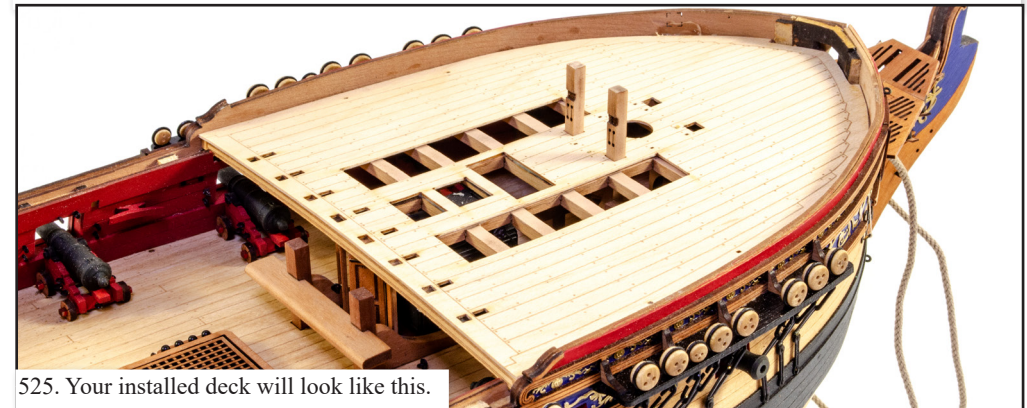

525. Your installed deck will look like this.

526. From the 1.5mm wood sheet, remove the two Forecastle Inner Bulwarks – Front (401).

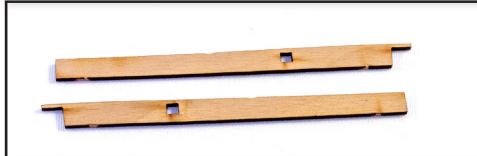

527. Soak these parts in hot water for 30 mins and clamp into position as shown. NOTE: You need to let these parts fully dry overnight as pearwood can expand a lot when wet and it needs to contract fully again before gluing.

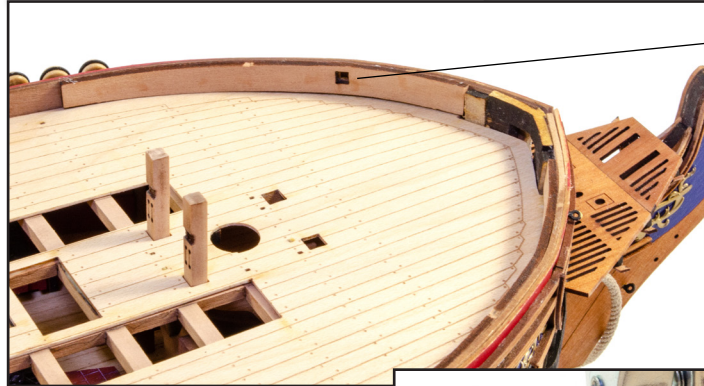

528. Before gluing, remove the small square cut-out on the inner bulwark face that's already on the hull. Now glue the bulwark part into position as shown so the square holes also line up.



529. From the 1.5mm wood sheet, remove the two Forecastle Inner Bulwarks – Rear (402).



530. Now glue these into position as shown.

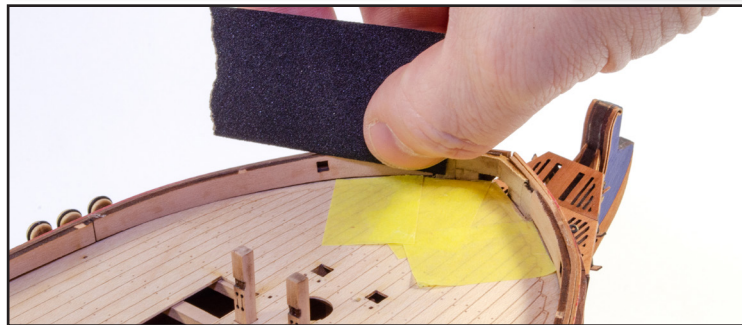

531. If there is a step between the MDF bow inserts and the bulwarks you just fitted, you can now sand that area flush with the bulwark. Use tape to protect your deck from damage.

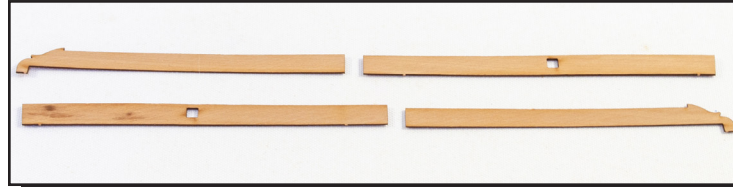

532. We will now perform the same tasks with the next parts, except no soaking will be needed here. From the 0.6mm wood sheet, remove the two Forecastle Inner Bulwarks – Front (96) and the two Rear sections (97).



533. Glue these in place and clamp as before. You can need to trim. The front sections will cover the MDF and meet at the bow.

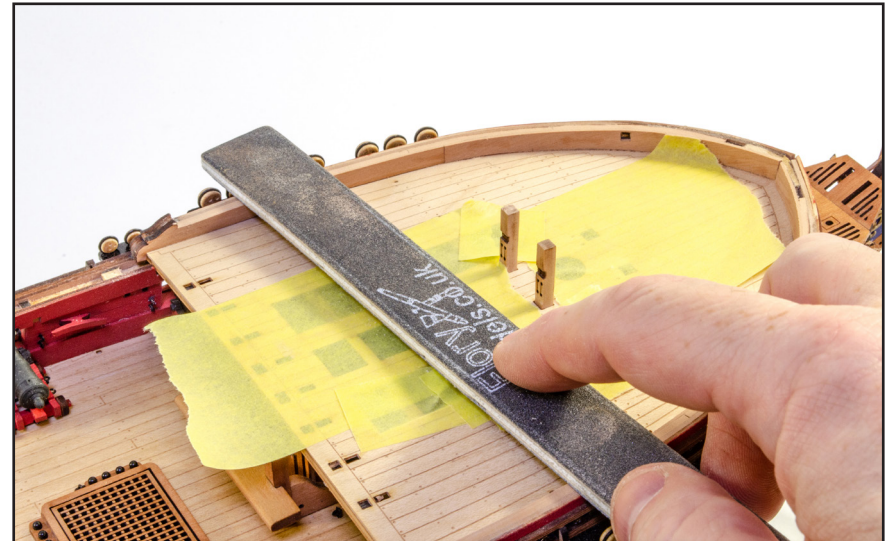

534. Use a sanding stick or a piece of sandpaper wrapped around a steel rule or similar and draw this across both bulwarks at once. This will sand away any irregularities and make them level to each other, and horizontal. NOTE: we recommend you cover the deck central section to stop it from being damaged, and to catch any dust where possible.

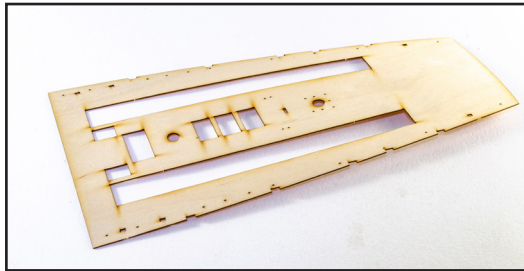

535. OPTIONAL: As we move to the quarterdeck, you have the option of planking this yourself, over the top of this Quarterdeck Pattern (49) from the 0.8mm ply sheet. Again, we do not supply planking strips for this option.

536. Using the standard option, remove the Quarterdeck Pattern (55) from the 0.8mm veneer sheet and test fit to your hull. If necessary, sand the edges slightly to make this fit. NOTE: We do recommend chamfering the underside back edge of this so it fits the stern snugly.

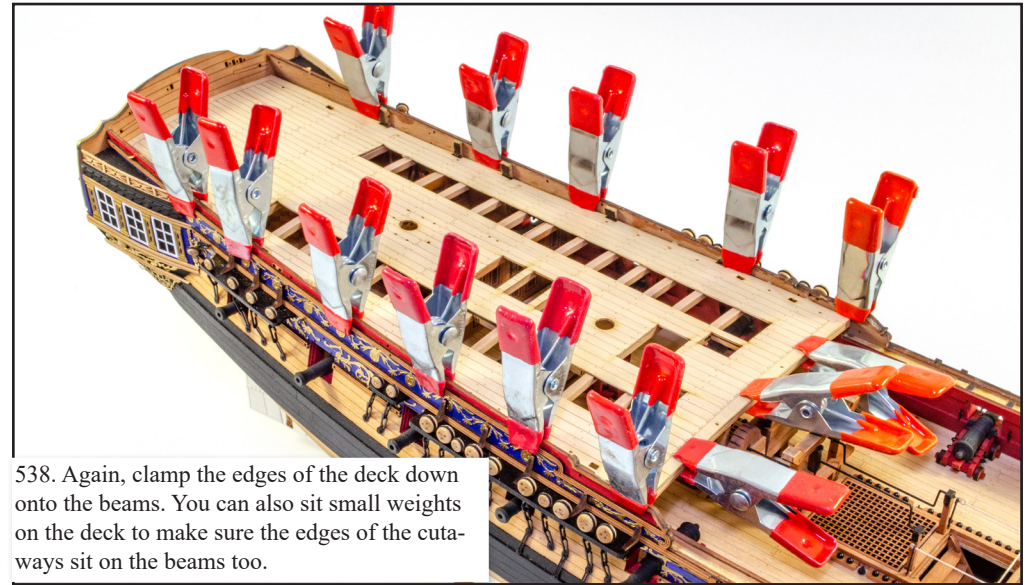

538. Again, clamp the edges of the deck down onto the beams. You can also sit small weights on the deck to make sure the edges of the cut-aways sit on the beams too.

539. Snip away the protruding MDF bulkhead ears and sand to remove any glue that might be present.

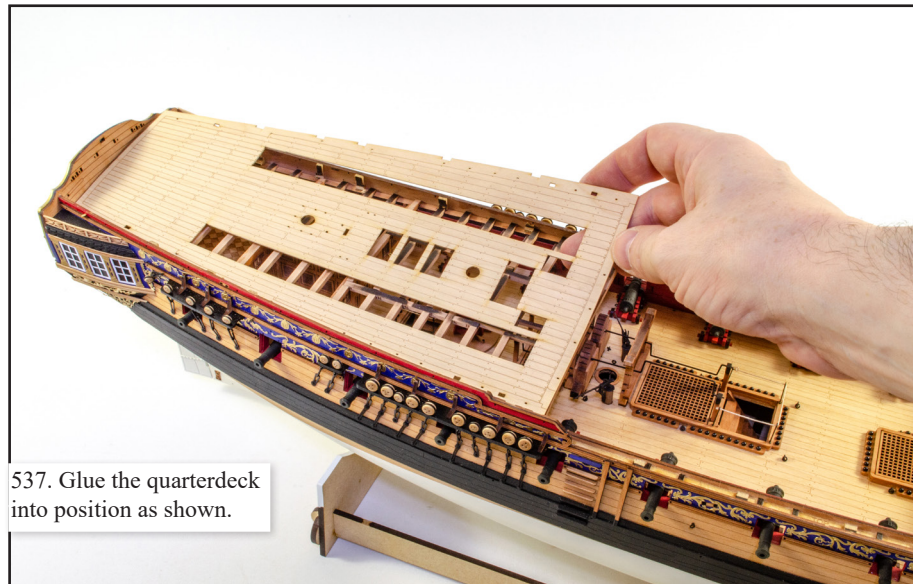

537. Glue the quarterdeck into position as shown.



540. From the 1.5mm wood sheet, remove the two Quarterdeck Inner Bulwarks – Rear (400).

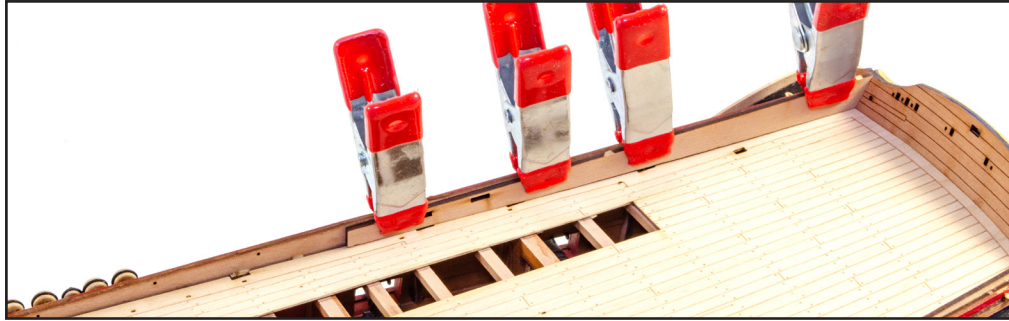

541. Glue and clamp in place as shown. We recommend you slightly bevel the rear edge, so it sits against the stern with no gap.



542. From the same 1.5mm wood sheet, remove the two Quarterdeck Inner Bulwarks -Front (399).



543. Glue and clamp these in position as shown.



544. From the 0.6mm wood sheet, remove the two Quarterdeck Inner Bulwarks - Left/Right (94, 95).

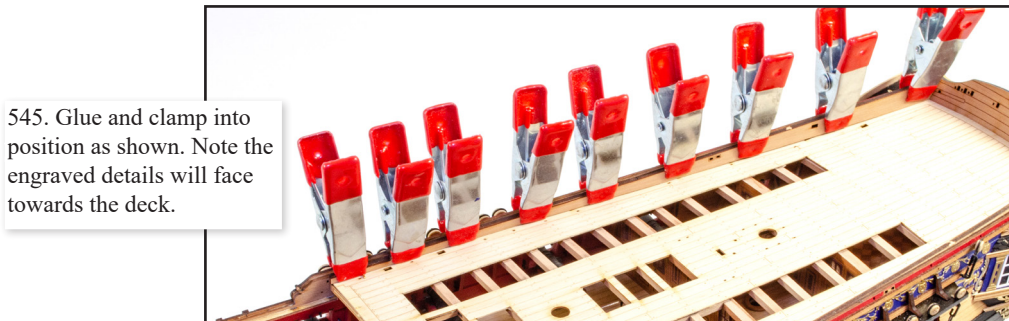

545. Glue and clamp into position as shown. Note the engraved details will face towards the deck.

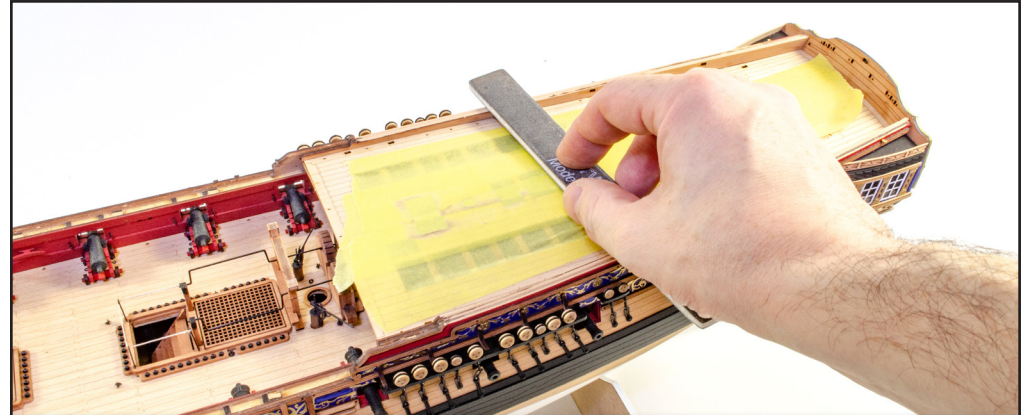

546. As before, draw a sanding stick or rule covered with medium sandpaper, over both bulwarks at the same time, so you sand them level to each other and also horizontal. Use tape on the deck to protect the details and to prevent dust ingress below.

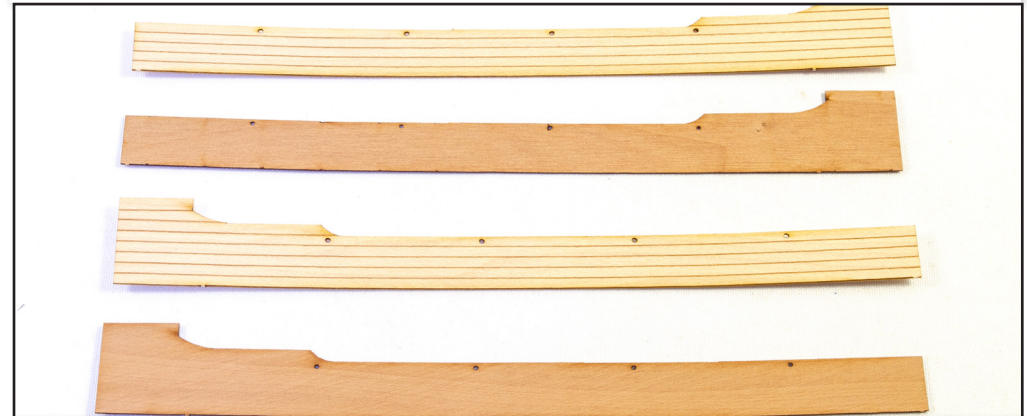

547. From the 0.8mm veneer sheet, remove the Gangway Deck Patterns - Left/Right (57/58), and from the 0.6mm wood sheet, remove the two Waist Gangway Patterns (100).

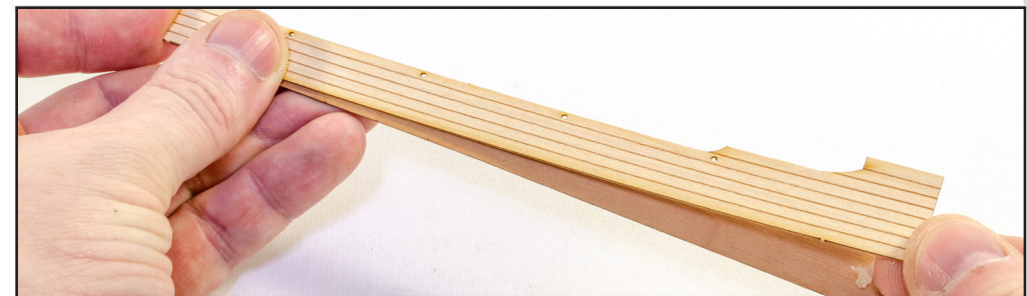

548. Glue each veneer to a wood piece and lay under something heavy and flat to prevent curling. NOTE: We suggest applying the glue to the underside of maple as this has less likelihood of curling when you apply the glue.



549. Sit the gangway in position (you may need to trim the length slightly) and mark the front and rear positions of where the adjoining gunwale will fit.

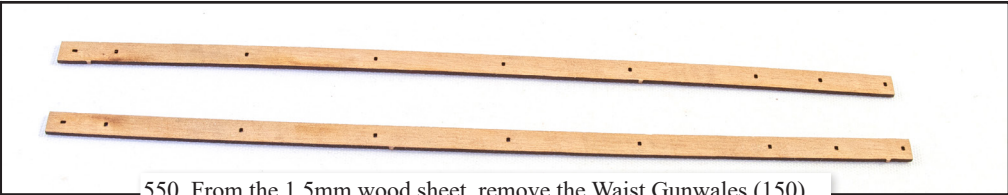

550. From the 1.5mm wood sheet, remove the Waist Gunwales (150).



551. Trim the gunwale to the correct length (note that the two holes closest together go towards the front) and sit the gunwale over the gangway. Where they overlap, draw a line on the gangway.

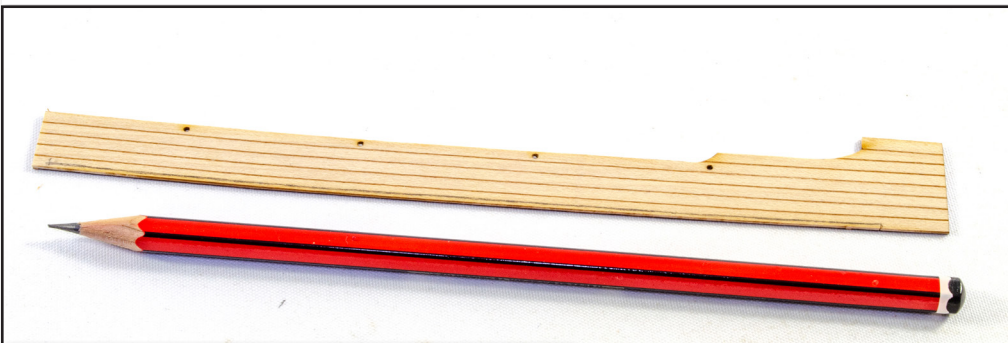

552. Your marked gangway will look something like this.



553. Remove the area on the gangway with a knife/sanding paper and test fit the gunwale to it to make sure it fits along the length. Also test fit the two parts to the hull to make sure they go together properly.

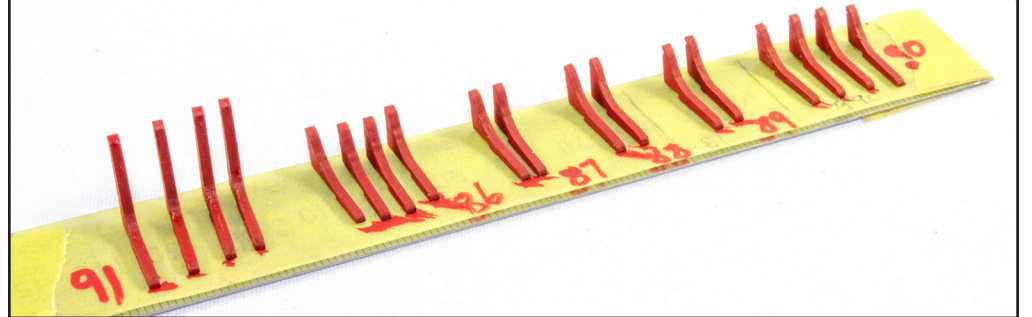

554. From the 1.5mm wood sheet, remove the Gangway Support Knees. These are numbered specifically for each position. You can paint these red before removing from sheet, then paint the edges. Notice that I have identified the parts whilst painting, to remove risk of mixing them up.

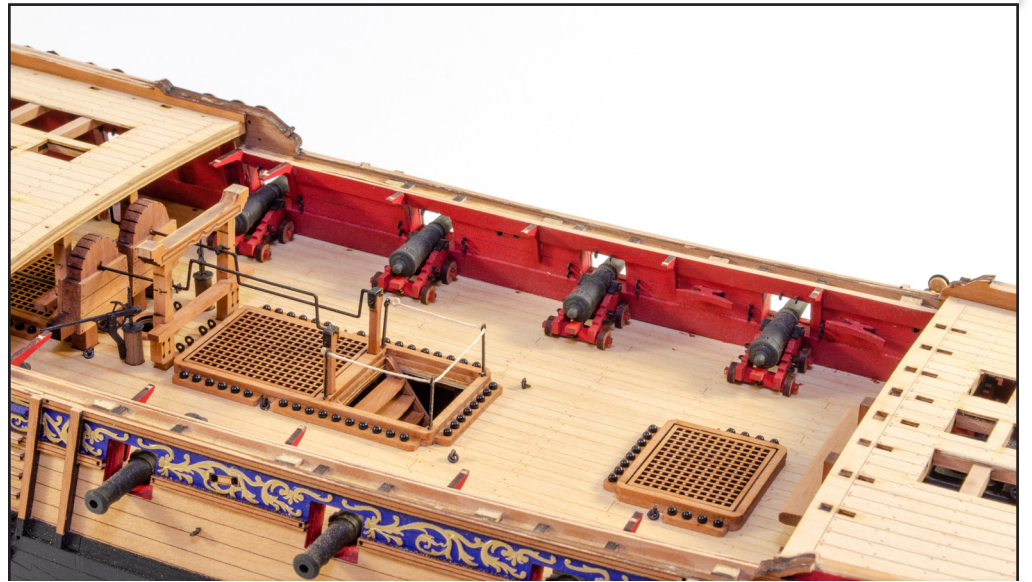

555. Glue the knees into position as shown here and on plans. For best results, remove a little paint from the joint area.

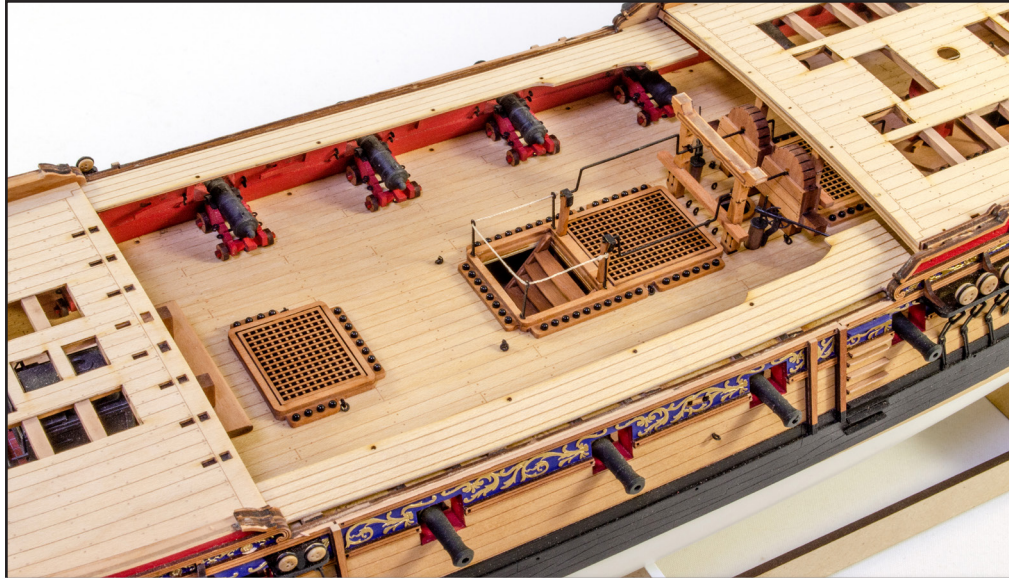

556. Now glue the gangways into position over the knees. Use a small weight to hold them down in the middle until dry.



557. From the 1.5mm wood sheet, remove the two Quarterdeck Front Drift Rail Patterns (405). From the 0.6mm wood sheet, remove the Quarterdeck Inner Main Drift Patterns (98).



558. Glue the 1.5mm piece into place followed by the 0.6mm as seen here. You may need to bevel the underside on these to conform the gangway camber.



559. Use a 0.6/0.7mm drill and drill through the outermost holes in the transom until the holes breaks through the resin stern decoration. That is where the lanterns will later fit.



560. From the 1.5mm wood sheet, remove the two Transom Knees (406).

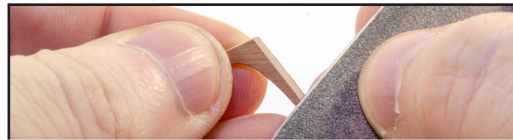

561. Test fit these into the hull (they will cover the engraved area where you drilled out the lantern mounting holes). You will need to sand/bevel the edges to get these to fit snugly to the transom and bulwarks.

562. Glue the transom knees into position.

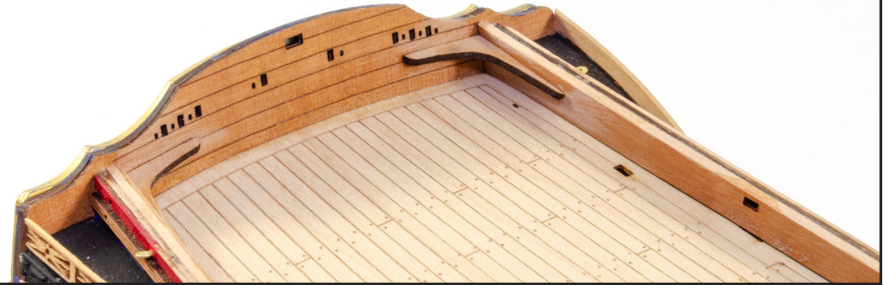

563. From the 1.5mm wood sheet, remove the Stern Ensign Staff Upper Bracket (403). From the 1mm wood sheet, remove eight Small Cleats for Stern Inner Fascia (169)



564. Glue these into position as shown.



565. From the 1.5mm wood sheet, remove four Quarterdeck Bulwark Cleats (398).



566. Glue into position as shown.

567. Your Sphinx should now look like this. At this point, you can mask the decks and paint the inner bulwarks on quarterdeck and forecastle, in red.

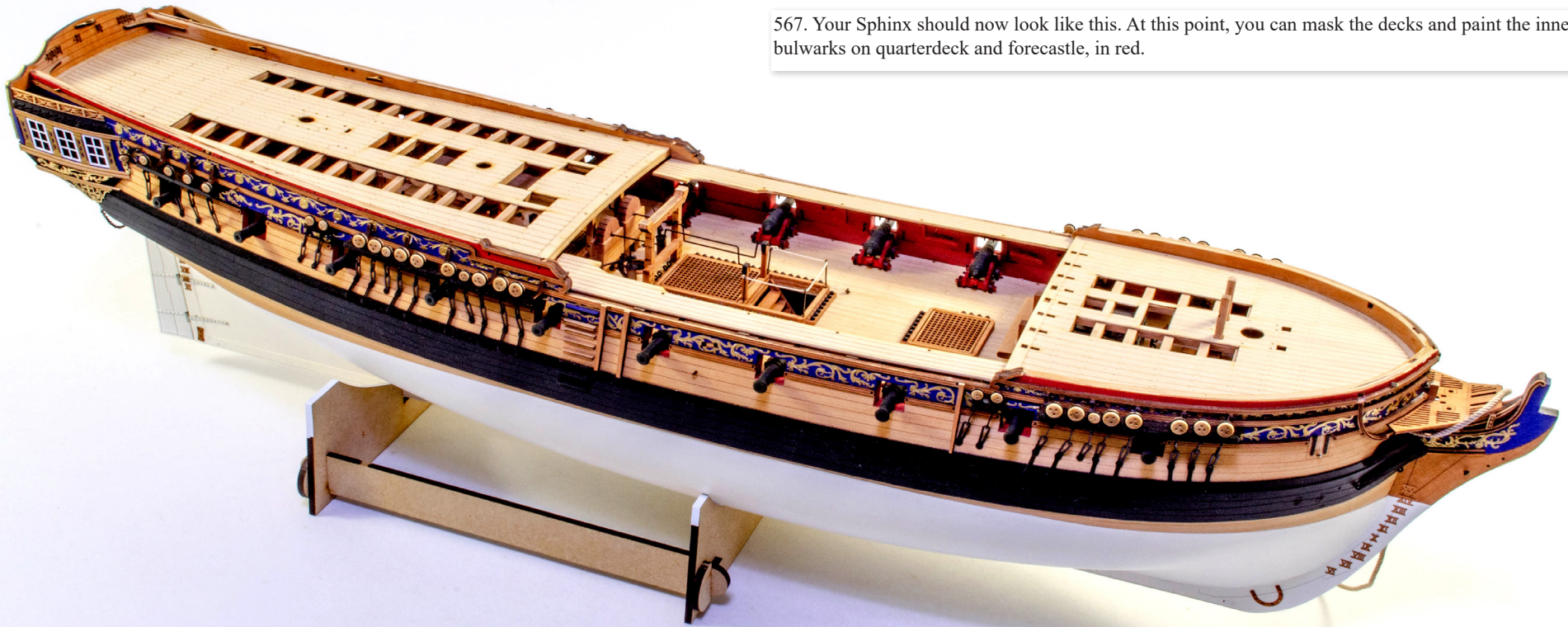

568. From the 1.5 mm wood sheet, remove the Stern Ensign Staff Lower Bracket (404). Bevel the rear edge to match the transom and then paint red.

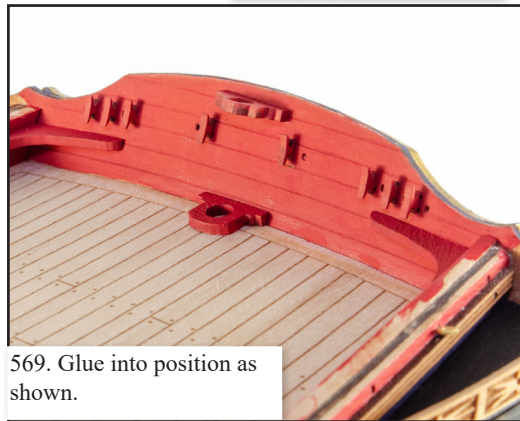

569. Glue into position as shown.



570. Gangway Stairs: On the 0.6mm wood sheet, you'll find an area for these two sets of steps, labelled as 'Gangway'. Remove one of everything apart from the sides where you need four, and the inner sides (124) where you will need two pieces.

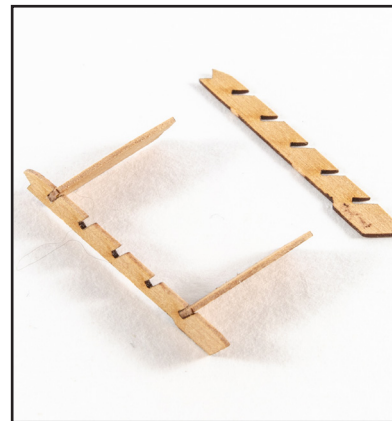

571. Remove char from the parts and glue a step into the upper and lower slots in one of the inner side parts.

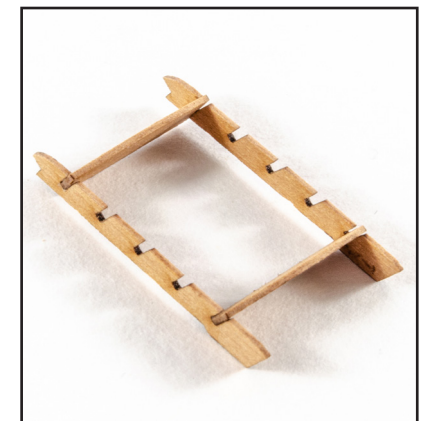

572. When dry, glue the other inner side into position.

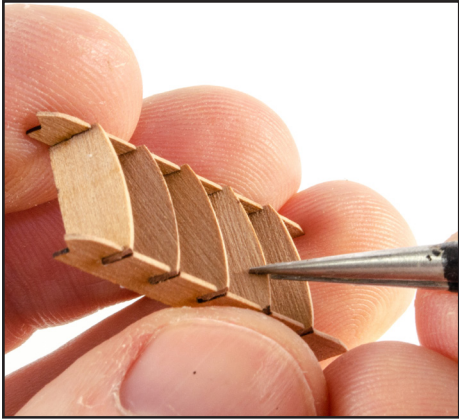

573. Now glue all remaining steps and leave to dry.



574. Take one each of the outer side panels as shown.



575. And glue into position. Make up another set of gangway steps.



576. Glue the gangway steps into the hull as show here and on plan.

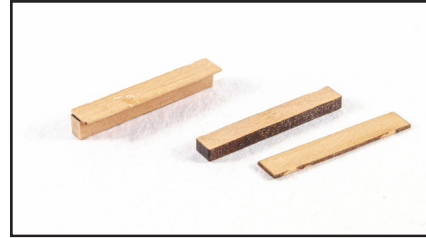

577. From the 0.6mm sheet, remove the two Quarterdeck Gangway Step Top (99). From the two Quarterdeck Gangway Steps (438). Glue as shown.



578. Fit these as seen here. You will need to bevel the inner edge to match bulwark. You may also need to trim them to the correct width, so they end at the gangway edge.

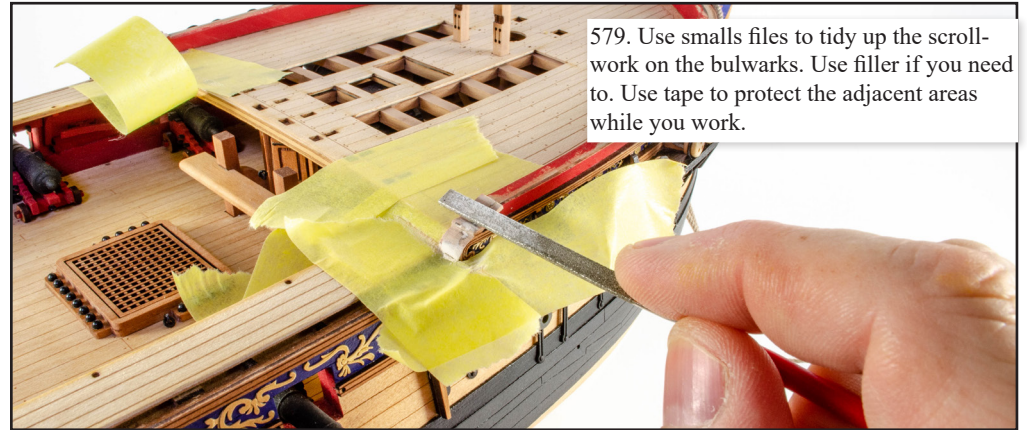

579. Use smalls files to tidy up the scrollwork on the bulwarks. Use filler if you need to. Use tape to protect the adjacent areas while you work.

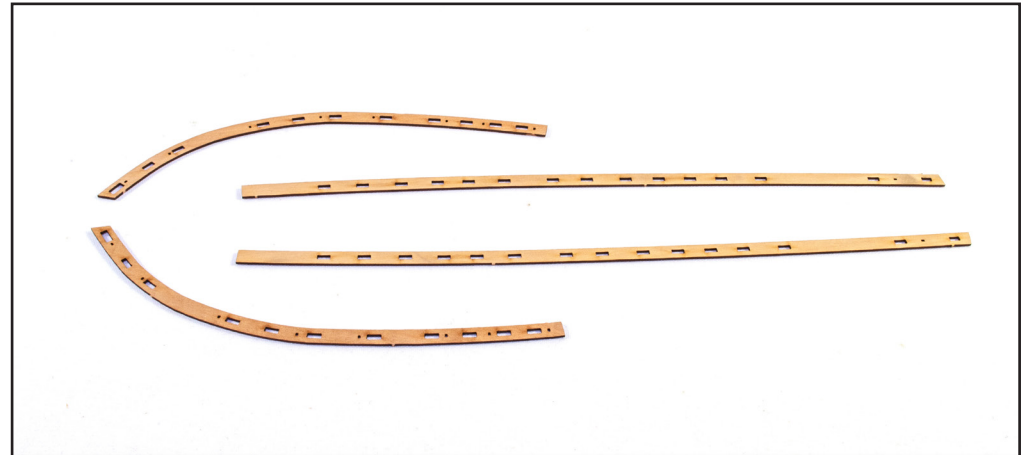

580. From the 1mm wood sheet, remove the two Forecastle Gunwales (149) and the two Quarterdeck Gunwales (170). Along with the 1.5mm waist gunwales you removed earlier, paint these parts in black.



581. Glue the gunwales into position as shown. These should be more or less flush with the inner bulwarks with only the minimal of overhang.



582. From the 3mm wood sheet, remove the two Fore Topsail Sheet Bitts (468). Remove the char.



583. Glue into position as in the gundeck as shown, occupying the front forecastle openings.



584. From the 2mm wood sheet, remove the Fore Bitts Cross Beams (426). Remove the char and slightly shape the ends as seen here.



585. Glue these parts in position across the stanchions as shown.

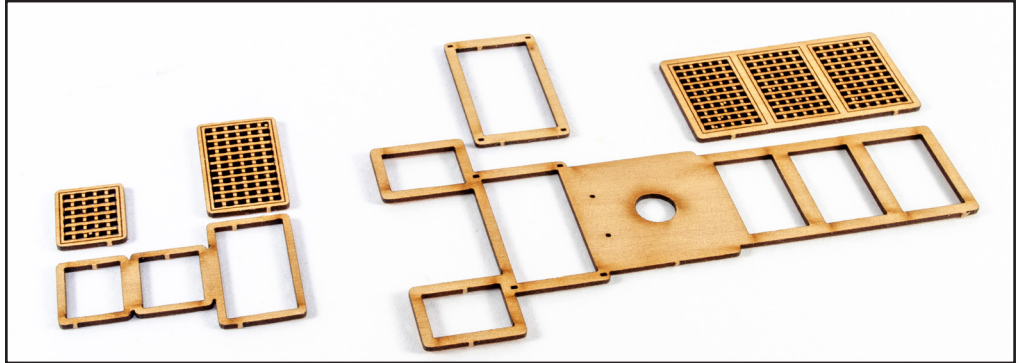

586. From the 1mm wood sheet, remove parts 181, 182 and 183 for the forecastle grating assembly. Also remove parts 184, 185 and 186 for the quarterdeck assembly.

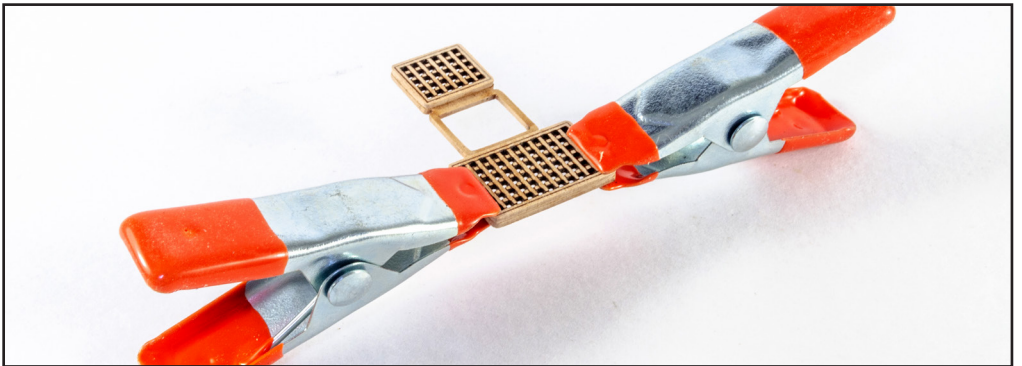

587. Glue together as shown on plan and clamp the edges properly while they set.

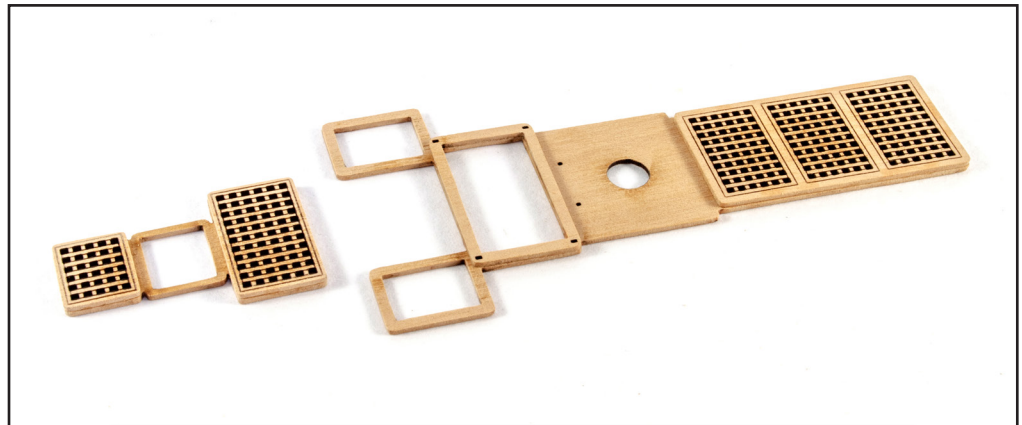

588. The completed assemblies will look like this.

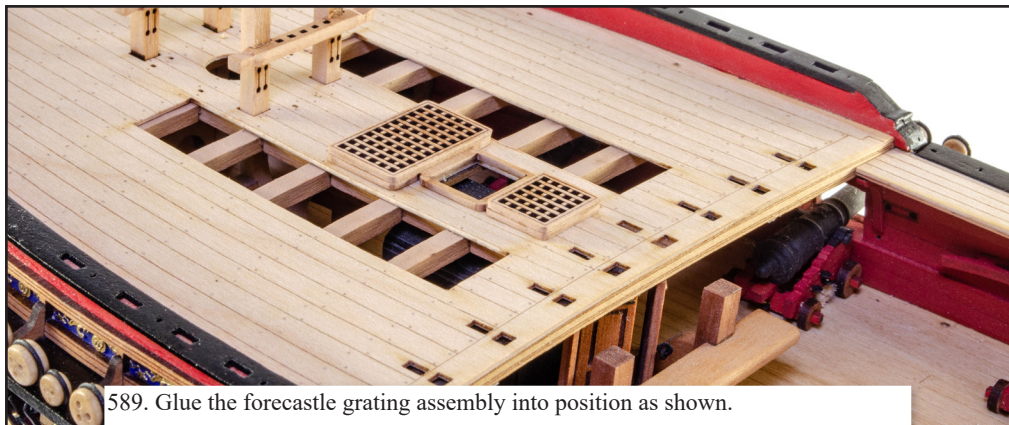

589. Glue the forecastle grating assembly into position as shown.

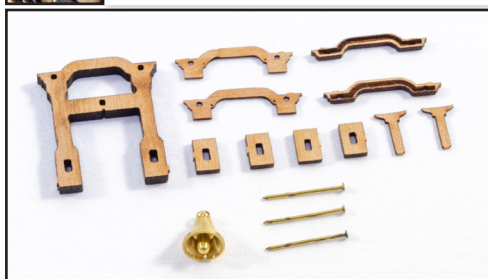

590. BELFRY: From the 2mm wood sheet, remove the Belfry Main Pattern (429). From the 1mm wood sheet, remove two Belfry Outer Canopy Pattern (177) and the four Belfry Lower Support Patterns (178). From the 0.6mm wood sheet, remove the two Belfry Canopy Mid Patterns (104), and the two Belfry Cleats (105). You will also need the Ship's Bell (F-9) and a few brass pins.

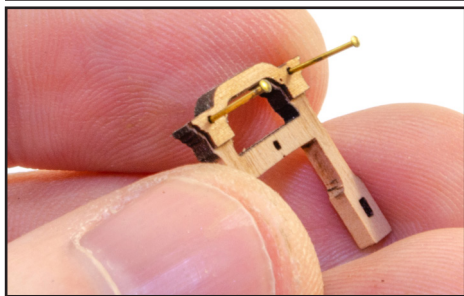

591. Glue the two Belfry Canopy Mid Patterns to either side of the main belfry pattern. You can use pins to align these properly.

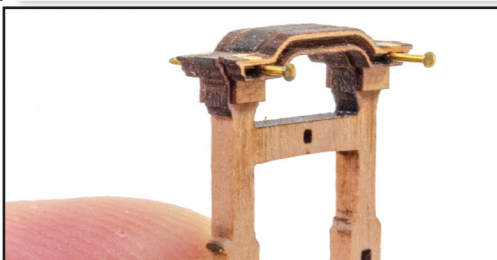

592. Now glue the Belfry Outer Canopy Patterns on top of the mid canopy parts. Again, use pins to align. You can either leave these pins in place and snip off on the opposite side or fill the alignment holes.

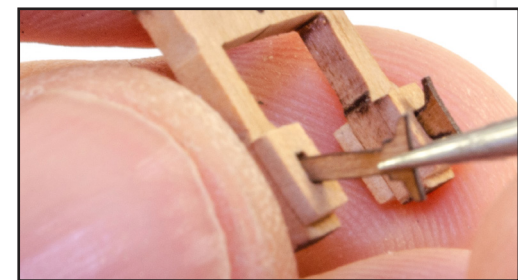

593. Glue the Belfry Lower Support Patterns into place either side of the belfry legs. Now glue the Belfry Cleats into position. When dry, sand any protrusion flush on the opposite side.

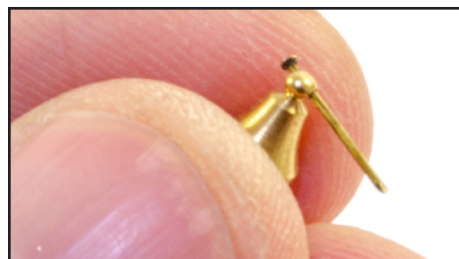

594. Slide a pin through the hole in the brass bell and bend the pin 90 degrees.

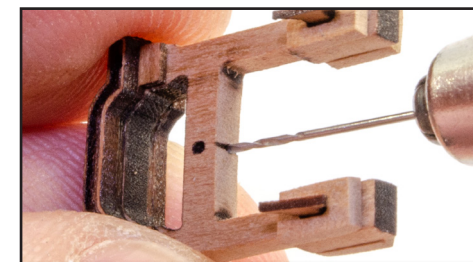

595. Use a 0.6mm drill to make a hole in the belfry cross bar as shown. The laser line will show you the location.



596. Cut short and glue the bent pin into the hole you just made, to hang the bell. You can either leave the belfry in natural wood or paint it black.



597. Mount the belfry to the forecastle deck as shown, with the cleats pointing aft.



598. From the 1.5mm wood sheet, remove the two Belfry Support Knees (353).



599. Glue into place against belfry as shown. If you painted the belfry black, the knees should also be black.



600. From the 2mm wood sheet, remove the six Forecastle Rail Stanchions (427). From the 1.5mm wood sheet, remove the six Forecastle Breast Beam Support Knees (352). From the 1mm wood sheet, remove the two Forecastle Breast Beam Rails (179).

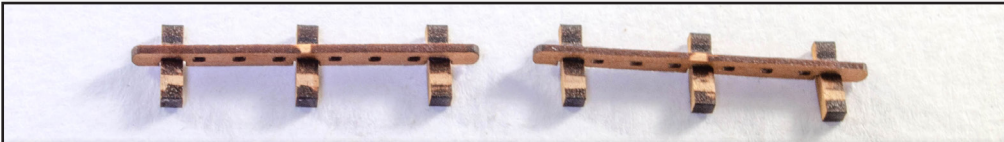

601. Assemble the stanchions to the rails as shown. Note that we don't put these in at 90 degrees, but one rail has the stanchions a degree or so over to one side to cater to deck camber, and the other rail has the stanchions a degree or so to the opposite side.

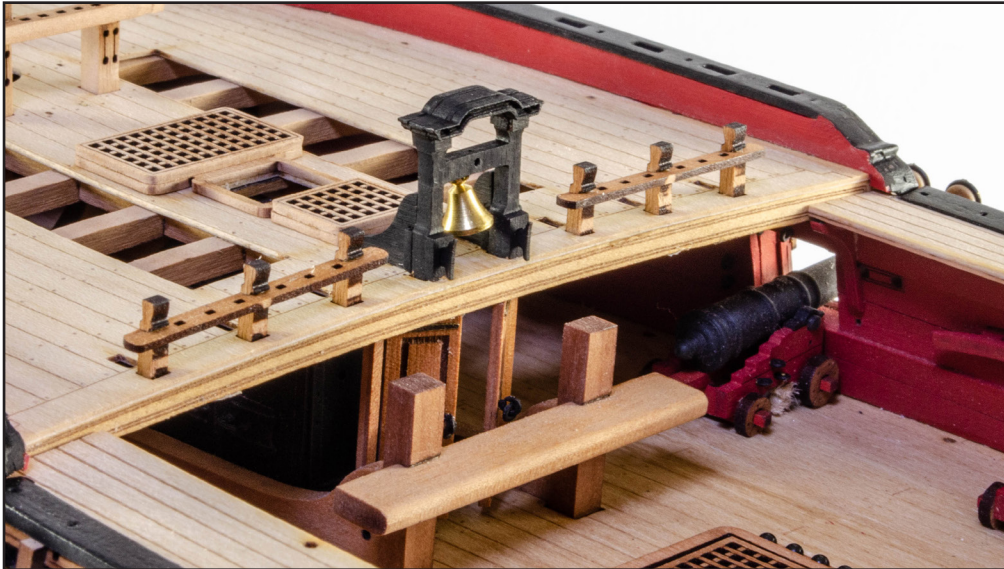

602. These should now be glued into the holes along the edge of the forecastle deck.



603. You can paint these black now or prior to fitting.



604. Take the support knees and glue into position as shown. These should also be painted black.



605. CATHEADS: from the 2mm wood sheet, remove the Cathead Sides (433, 434). From the 0.6mm wood sheet, remove the Cathead Top Pattern (84), Cathead Bottom Pattern (85), and the Cathead End Moulding (86).



607. Glue the top and bottom patterns into place so the pattern holes are at the square end of the cathead.



609. Remove all char and sand the top and bottom patterns so they blend into the rear cathead angle. Make two catheads.



606. Glue one side 434 to another side 433 (the engraved areas will be on the outside).



608. Glue the end moulding into position.



610. The holes in the bulwark are deliberately left smaller than required for alignment and part integrity when assembling. You will now need to open these up to fit the catheads. Use small files and a sharp, narrow blade to open these up to size. For an indication, the inner bulwark will have the hole cut down to deck height, and on the outside hull, the hole will extend up to the gunwale. Use tape to protect the deck whilst you work.



611. Test fit the cathead as you go. When complete, paint the catheads black and glue into position.



612. From the 2mm wood sheet, remove two Cathead Knees (435).



613. Glue these in position under the cathead as shown. You will need to cut back a little of the decorative trim. You will also need to slightly bevel the knees to suit the angles you have. When fitted, paint black.

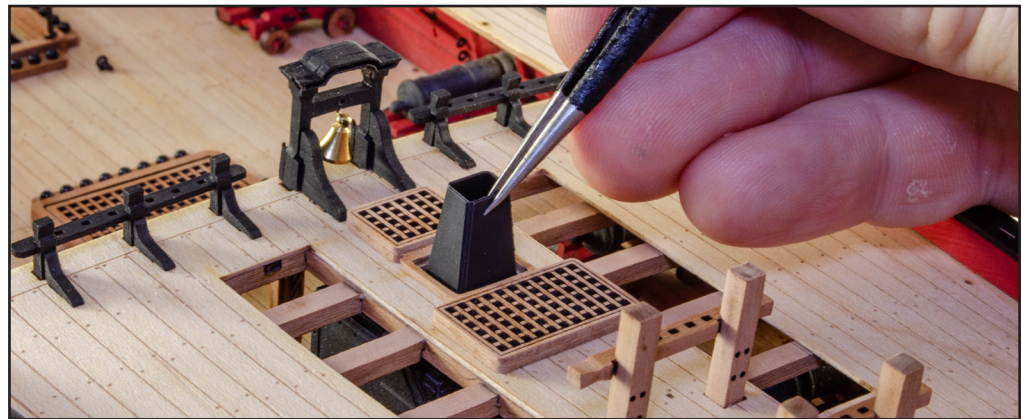

614. You can now install the stove flue you made earlier. Paint this matt black first and possibly weather using a little steel pigment powder. Use CA to glue.



615. We now turn attention to the quarterdeck. Glue the remaining grating assembly into position as shown.



616. Quarterdeck Ladder: All parts for this ladder are in the same area on the 0.6mm wood sheet, labelled as 'Quarterdeck'. Remove all parts for this assembly, 116, 117, 118 and 119.



617. Glue a step to the first and last slots on an inner ladder side.



618. When dry, glue the other ladder side into place.

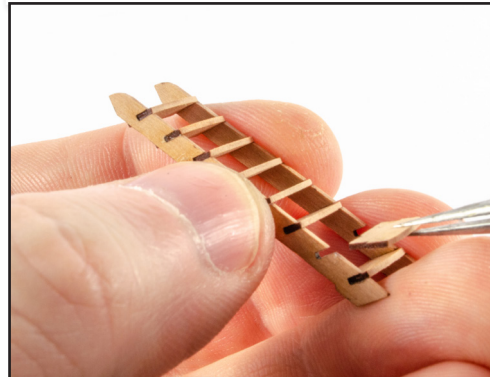

619. Now glue the remaining ladder steps into position.



620. Take the engraved ladder outer faces....



621. ...and glue into position as shown.

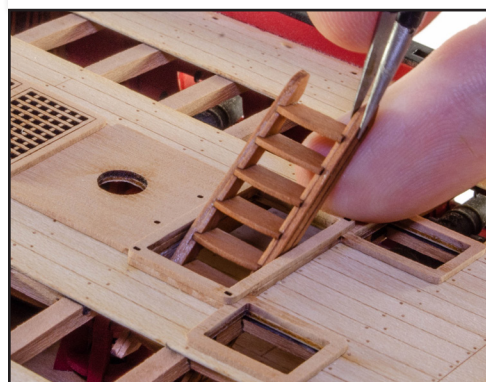

622. Glue the ladder into position through the quarterdeck coaming as shown.



623. Note the direction of the ladder too.

624. From the 2mm wood sheet, remove the Capstan Whelps (437). From the 1mm wood sheet, remove the two Capstan Chocks (250), Capstan Lower Drum Head (251), Capstan Drum Head for Bars (252), Capstan Top Drum Head – Quarterdeck (255). Use a length of dowel to help build the capstan body as before.

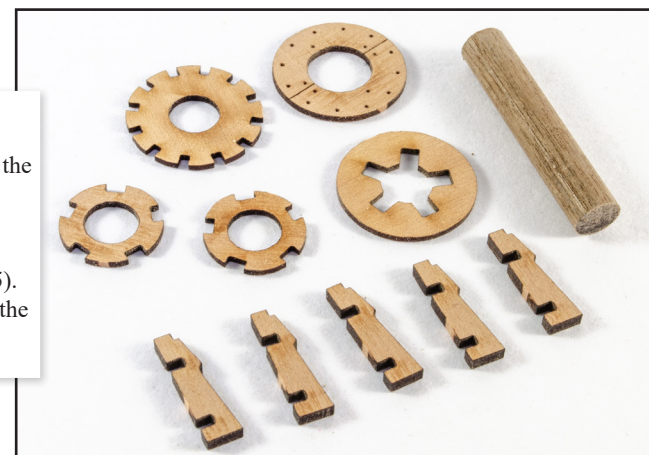



625. Glue the whelps to the checks to create a drum.



626. Now glue the lower drum head into position.



627. On top of the drum head, glue the drum head for bars.

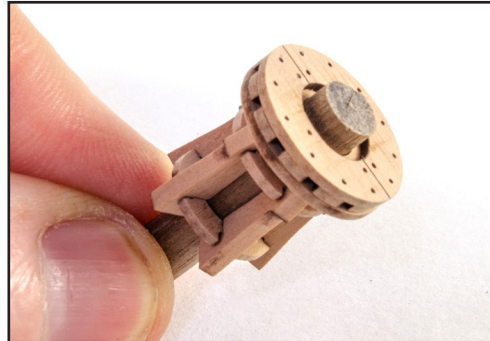

628. Finally, glue the quarterdeck drum head into place.



629. Your finished capstan will look like this. You can now paint the capstan in red.



630. Push a length of 6mm dowel down into through the quarterdeck and into the gun deck capstan below. Slide the new capstan into place over this as shown. Use a pencil to mark where the dowel at the height of the capstan. Remove the dowel and cut to the length you marked. Now re-insert it with glue and glue the capstan into place.

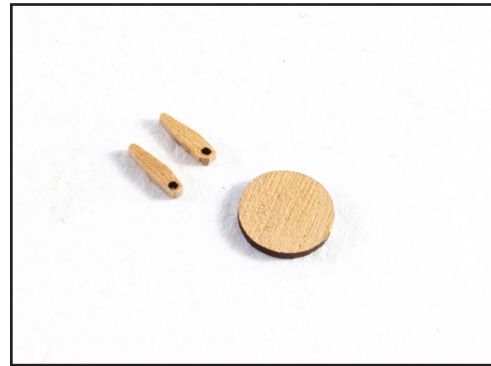

631. From the 1mm wood sheet, remove the Upper Drum Head – Quarterdeck (256), and two Capstan Pawl Heads (257).



632. Paint the drum head black and sit on top of the dowel in the centre of capstan. Now glue the pawls to the coaming and insert two brass pins for the bolts. Paint the pins black.



633. From the 1mm wood sheet, remove a Mizzen Mast Base. Sand the upper edges slightly round and glue into position. Note this hole is elongated for the mast rake, and that should run fore to aft.

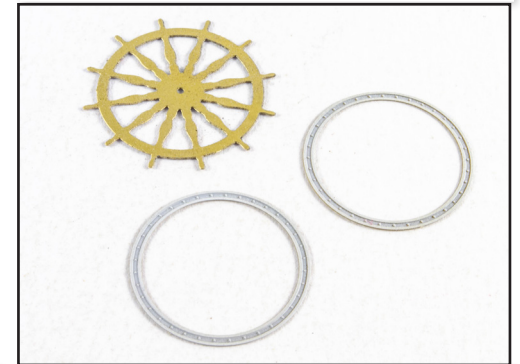

634. Ship's Wheel: From the 0.4mm PE sheet, remove the Ship's Wheel (PE-114) and from the 0.2mm PE sheet, remove the two Ship's Wheel Outer Ring Plates (PE-42). Also remove the two Ship's Wheel Inner Ring Plates (PE-43)...not shown in this picture or build.

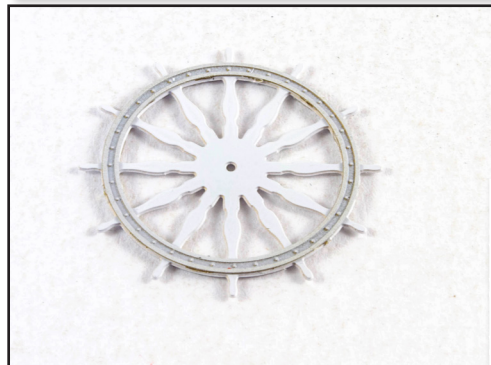

635. Glue the outer rings into place as shown. Also glue the inner rings (not shown) using the brass rod to help you align them. When complete, prime/paint the wheel in white. If you wish you can add a subtle enamel wash to the details. Also paint the handles in a wood colour.

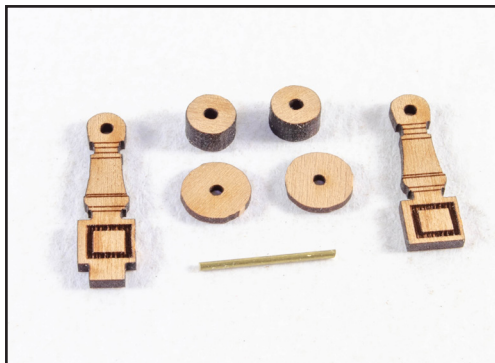

636. From the 1.5mm wood sheet, remove the Ship's Wheel Standard – Front (340) and the Ship's Wheel Standard – Rear (341). From the 3mm wood sheet, remove the two Ship's Wheel Drum Centres (451). From the 1mm wood sheet, remove the two Ship's Wheel Outer Drum parts (201). Also cut a piece of brass rod 13mm long.



637. Using the rod as alignment, glue the two inner drum parts together, and then glue an outer drum to each side.



638. Glue the Ship's Wheel Standard – Rear into position, along with the rod which will be flush on this rear side.

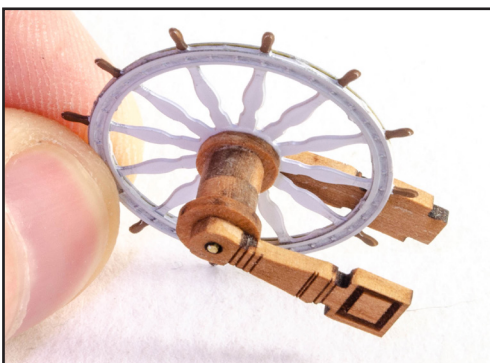

639. Now glue the wheel into place, followed by the Ship's Wheel Standard which will align with the rear part.

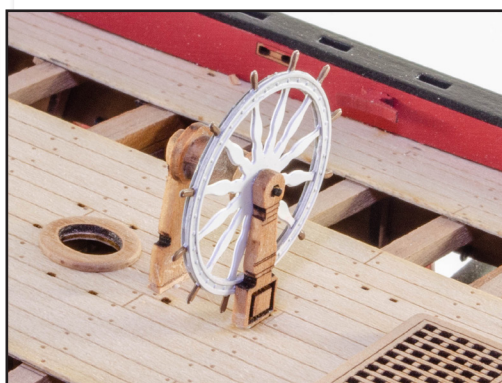
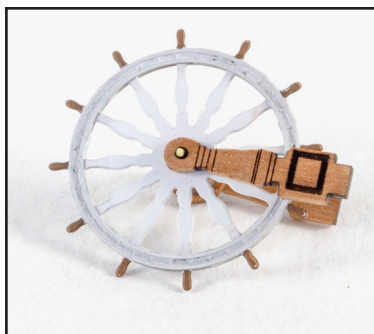

640. Glue the wheel assembly into place as seen here.



641. Binnacle: from the 1mm wood sheet, cut the Binnacle Outer Pattern – Towards Wheel (162), Binnacle Pattern (163), two Binnacle Side Patterns (164), Binnacle Inner Patterns – Top/Middle/Bottom (167/166/165), and the Binnacle Canopy (168). From the 0.2mm PE sheet, remove the Compass Pattern for Binnacle (PE-45). You will also need the brass Binnacle Chimney (F-10).



642. Glue the compass pattern over the middle inner pattern, covering the engraved positions.



643. Glue the middle inner section to the inside of one of the side panels. The compasses will face upwards.



644. Now glue the bottom and middle inner sections into place.



645. Glue the opposite binnacle side into place and allow to dry thoroughly. Make sure everything is nice and square.

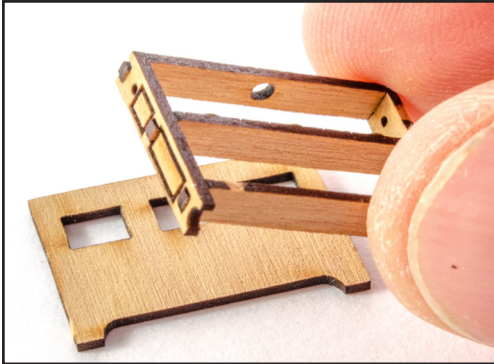

646. Glue the Binnacle Outer Pattern – Towards Wheel, into place and clamp until dry.



647. Glue the other binnacle side into position.

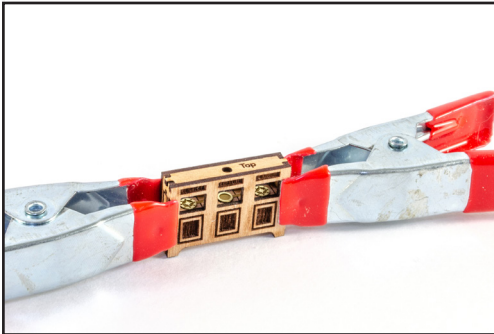

648. Again, make sure you clamp everything so the joint is closed up all around.



649. Remove all char from the edges and then glue the binnacle canopy into place.



650. Paint the brass chimney in black and glue into the canopy hole. Also take two Eyelets (PE-106) from the 0.4mm PE sheet and glue them into the sides of the binnacle. Paint them black.



651. Glue the binnacle into place with the 'Towards Wheel' side.



652. Locate the Quarterdeck Breast Beams – Lower/Middle (151/152) on the 1mm wood sheet, and also the Upper Breast Rails – Upper/Top (77/78) from the 0.6mm wood sheet. I have left these in the sheets to help identify during assembly. You can also pre-paint them at this stage for ease but remember the 0.6mm parts only need paint on one side, and the same for the bottom rail.



653. Glue the lower rail into position at the edge of the quarterdeck. This fits within the engraved area.

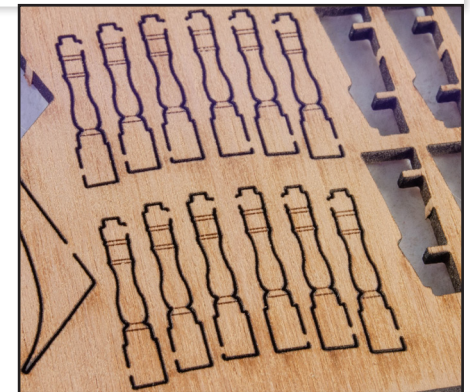

654. All of the Quarterdeck Breast Rail Stanchions are found on the 2mm wood sheet. They are numbered 436a thru 436f. Can you individually number these so you don't get them mixed up or remove one at a time from the sheet.



655. Sand the pillar part of the stanchions so they have a curve to them.



656. Glue each stanchion into position in the lower rail making sure they are both upright and in alignment with each other. Leave these to set thoroughly.



657. Slide into position and glue the middle rail. This will sit on the lower stanchion shoulders.



658. Glue the top rail into position as shown (painted black underneath).



659. Now glue the upper rail over the this so the small holes align with the rail below.



660. From the 1.5mm wood sheet, remove the two Quarterdeck Breast Rail Stanchions – Gangway (407) and sand the curved area to represent a pillar. From the 1mm wood sheet, remove the two Quarterdeck Waist Rail Patterns (153). You can paint these black now if you wish.

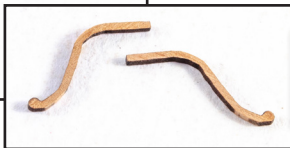

661. From the 1mm wood sheet remove the two Quarterdeck Waist Rail Upper Patterns (154).



662. Using your plan as reference, mount the two stanchions on the gangways as shown and then fit the rail patterns by slotting over the stanchions and gluing to the mid breast rail. You may need to trim the latter to length. Now glue the upper rail pattern so it sits on the rail you just installed and up against the upper rail. Again, trim to fit. Paint all rails/stanchions in black.



663. Using your plans as reference, fit all deck eyelets (PE-106) and deck cleats (398). Next to the binnacle, fit four eyelets (PE-81). Paint all eyelets black. On the forecandle deck, install the Belaying Pins (PE-152) from the 0.6mm PE sheet. Paint black.



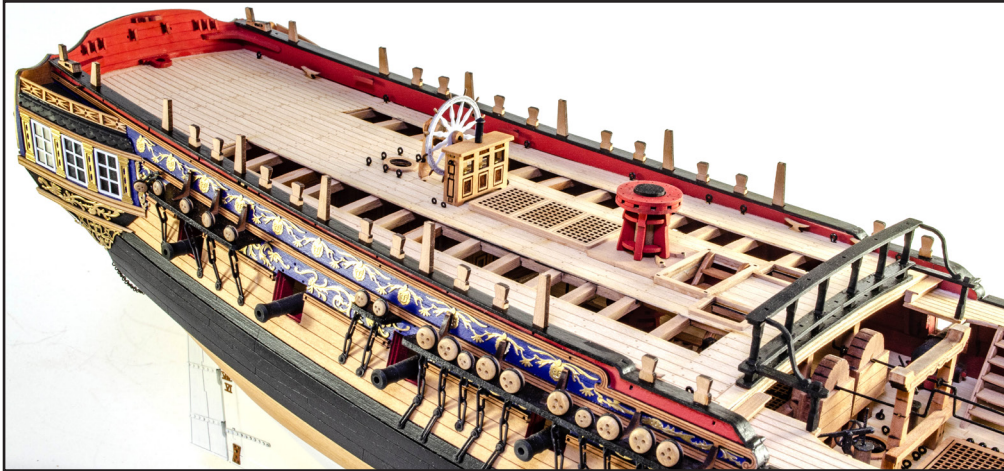

664. Using your plans as reference again, install the Quarterdeck Rail Stanchions and Quarterdeck Timberheads from the 1.5mm wood sheet into the slots on the gunwales. Each part is specific to its location. Shape the top of each timberhead slightly too on the inner and outer upper sides. From the 1.5mm wood sheet, also install the Quarterdeck Front Timberheads (408), two on each side. These glue into the slots in that area. Paint all stanchions and timberheads in black.



665. From the 1.5mm wood sheet, fit all Forecastle Timberheads and the Fish Davit Crutch into position. Again, shape the top of these parts and paint black. Also fit the two forward timberheads (428) from the 2mm wood sheet. From the 3mm wood sheet, install the two Forecastle Gunwale Snatch Blocks (455). Paint all new timber in black.



666. From the 1.5mm wood sheet, remove the two Quarterdeck Fife Mail Rail Patterns (354). From the 0.6mm wood sheet, remove the four Quarterdeck Fife Mail Rail Outer Patterns (91).

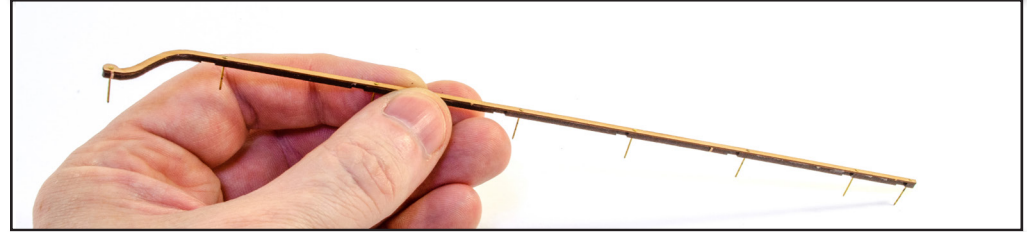

667. Glue one of the outer patterns to the main pattern, using brass pins to help align the parts.



668. Now glue an outer pattern to the opposite side of the rail, sandwiching the 1.5mm part and creating slots in the underside.

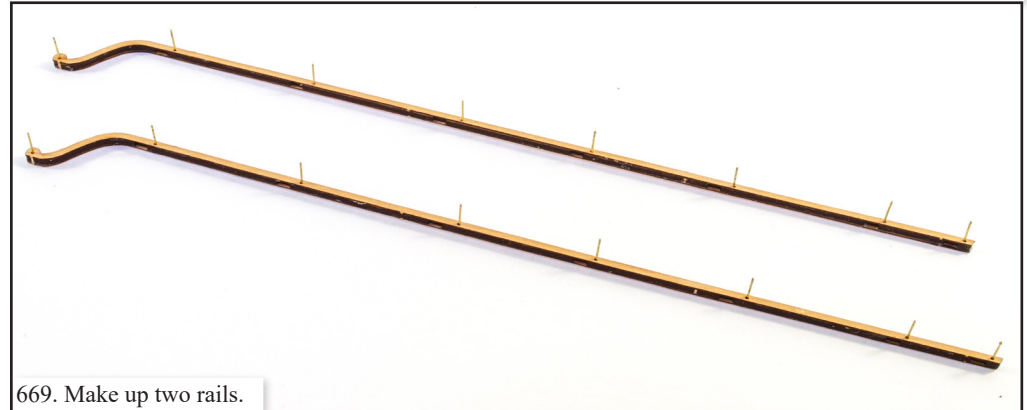

669. Make up two rails.



670. When dry, remove the pins and carefully sand to remove the char and make the surfaces even and level. Use filler in the pin holes and then paint the rails black.



671. Glue the rails to the quarterdeck rail stanchions and make sure the forward moulding is glued to the gunwale.



672. From the 3mm wood sheet, remove the two Seat of Ease Patterns (452). From the 0.6mm wood sheet, remove the two Seat of Ease Tops (135).

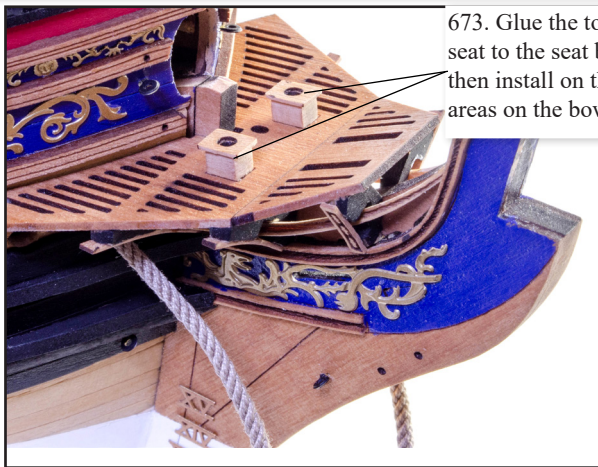

673. Glue the top of the seat to the seat bottom and then install on the engraved areas on the bow grating.



674. From the 0.8mm wood sheet, remove the two Bow Main Rail – Inner (304), the Bow Main Rail – Outer Right (302), and the Bow Main Rail – Outer Left (303). From the 1mm wood sheet, remove the Main Rail Upper Finishing Patterns – Left/Right (175/176).

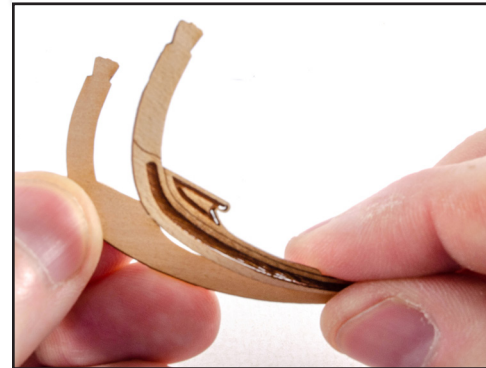

675. Glue the inner and outer rails together.



676. Clamp along their whole length to prevent any curling.



677. Glue the upper finishing patterns into place and clamp until dry.



678. Carve/Sand the top of the rail timberhead as shown.

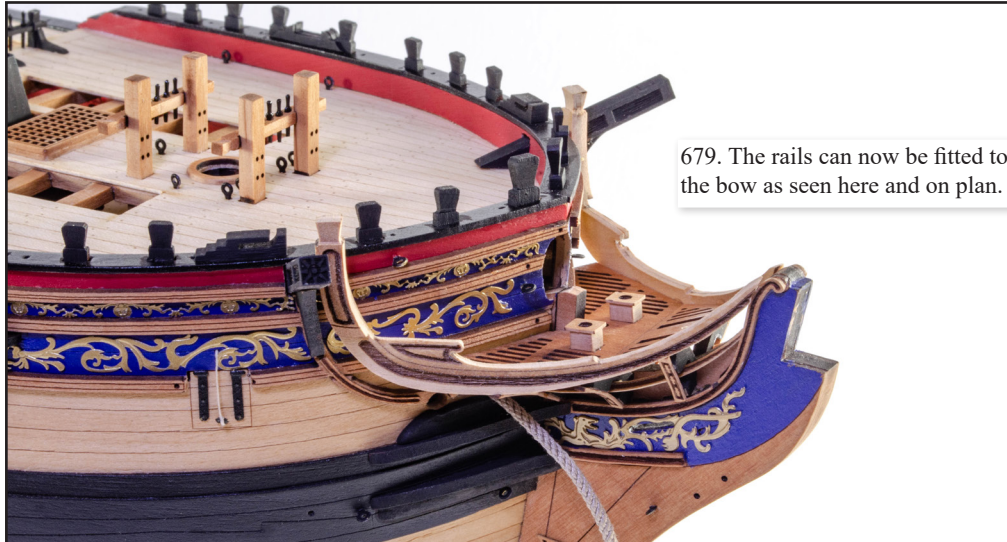

679. The rails can now be fitted to the bow as seen here and on plan.

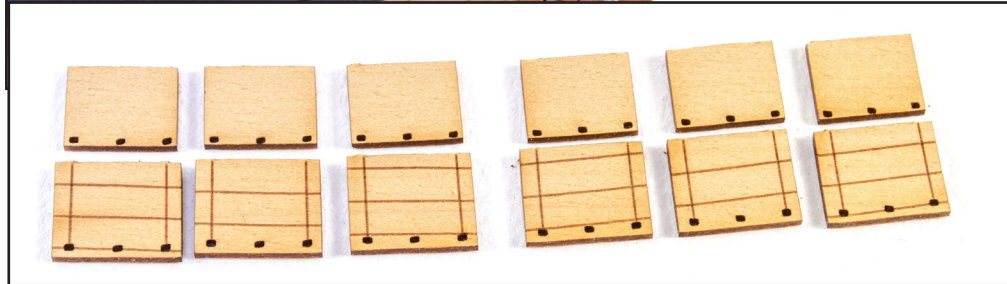

680. From the 0.8mm wood sheet, remove the following pairs of parts for the gun port lids: 293 + 294, 295 + 296, 297 + 298, 297 + 301, 295 + 300, 293 + 299. Don't mix these parts up as each gun port lid is specific to individual ports.

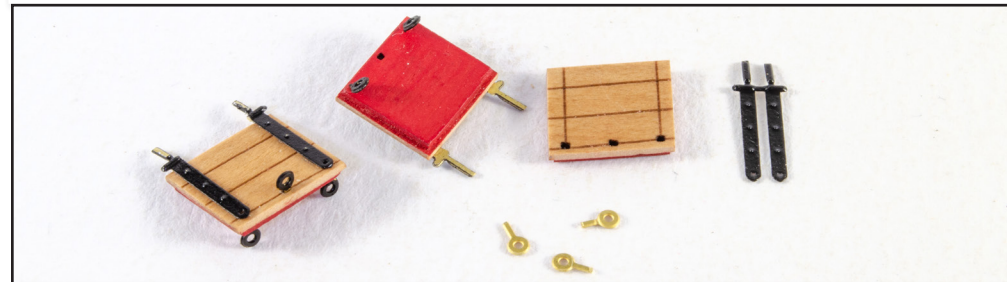

681. Paint one side of the inner port lid in red and then glue these to the inside of the lids. Paint the edge of the port lid around the part you glued. From the 0.4mm PE sheet, remove the Gun Port Lid Hinges (PE-111), and the Gun Port Lid Eyebolts (PE-109). Split the hinge pairs and glue to them over the engraved marks on the outer lid. Add two eyebolts to the inside of the lid and bend slightly upwards. Add another eyebolt to the outside of the lid and bend slightly upwards. Paint all metal parts in black.



682. Add a short length of 0.1mm natural thread to the upper hole above each of the three rear gun ports. Glue the gun ports into place, checking that the lid is the correct one with the engraved planking patterns, and then tie the other end of the thread to the outside eyebolt. Seal the thread and cut off at eyebolt.

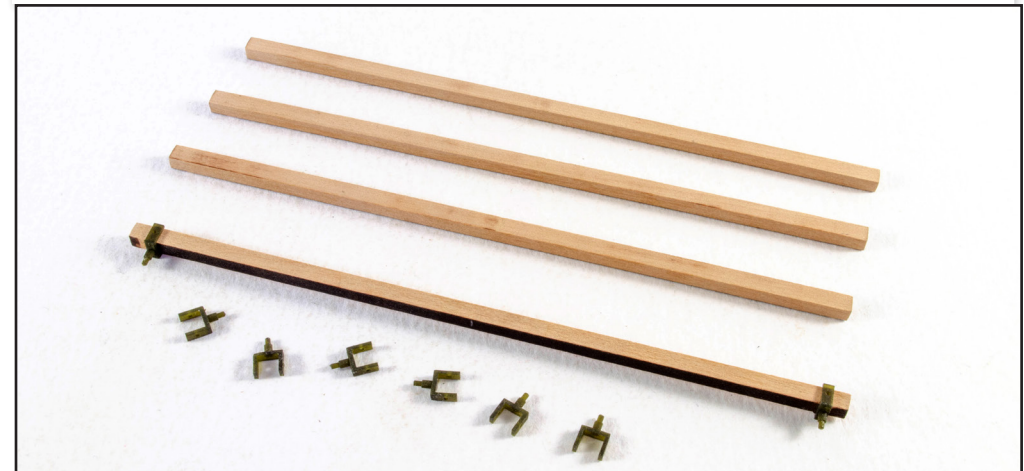

683. From the 3mm wood sheet, remove the four Boat Cross Beams (469, 469a). Since this prototype, two beams have been engraved to help you place the boat cradles. Check your plans to see the position of the engraved/non-engraved beams in the mounting holes. Measure between the holes on the gangways and transfer those marks to each beam. On the prototype the holes are around 99.5mm to 100mm apart. Use CA gel to glue to the Boat Beam Support Brackets (F-6) into position as shown. Test the beam to make sure the brackets sit comfortably in the gangway holes. If the rearmost beam slightly catches on any of your chain pump handles (depending on position of handles), then slightly notch the beam to compensate.

IMPORTANT: DO NOT fit the beams at the moment as they will impede the rigging process.



684. Take each of the boats cradles from the 2mm wood sheet (24ft Launch – 441, 442), (28ft Pinnace – 443, 444), (22ft Yawl – 439, 440), and drill/fit eyelets to them for lashing down the boats. Use PE-106 eyelets for this.



685. On the forward most engraved beam, glue the cradle parts 441, 443, and 449. On the rearmost engraved beam, glue the cradle parts 442, 444, and 440. You can temporarily test fit the beams again along with the boats to make sure they fit OK.

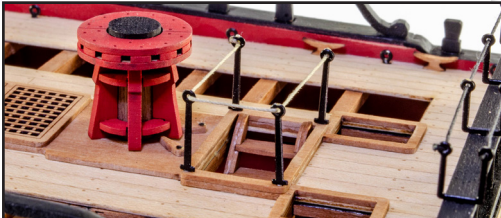

686. From the 0.4mm sheet, remove four Ladderway Stanchions (PE-105) and glue into position around the quarterdeck ladderway. Use 0.5mm natural rope to rig.



687. From the 0.4mm PE sheet, remove five Quarterdeck Breast Rail Hammock Cranes (PE-104). Slot these into the holes in the breast rail, running through all rail sections until they plug into the bottom ones. These should be painted black. Use 0.5mm black thread to rig.

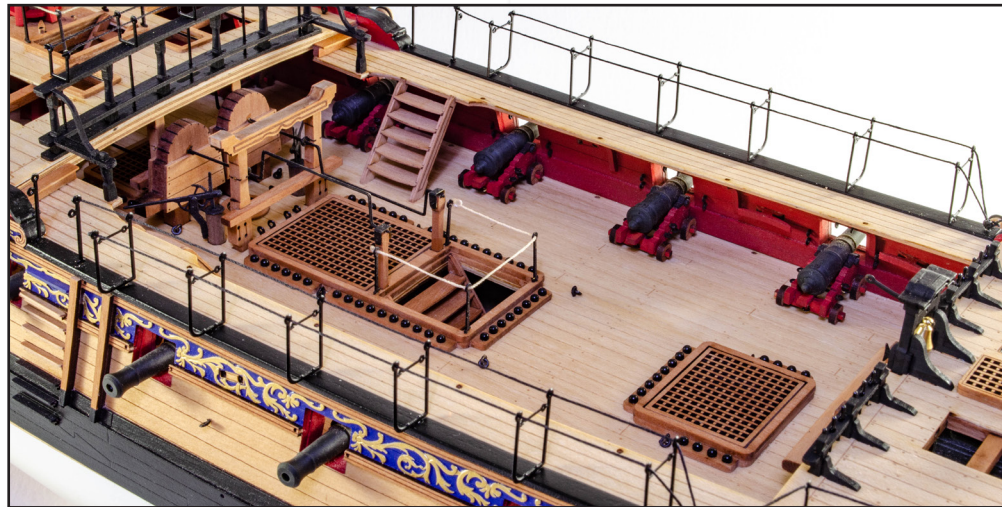

688. From the 0.4mm PE sheet, remove twelve Waist Hammock Cranes (PE-91) and four Waist Stanchions (PE-92) and glue into position on the waist gunwales. If necessary, slightly open up the holes with a drill bit. Also add a PE-106 eyelet to the forward gunwale hole.



689. On the forecandle gunwale, add the Forecandle Stanchions (PE-84 thru Pe-90) as shown on the plan. Also add an eyebolt (PE-106) to the forward most hole on gunwale). Paint all metal parts in black. Rig the stanchions with 0.5mm black thread, as shown on plan. For the time being, we will leave off the hammock cranes on the quarterdeck as this could impede the fitting of the shrouds.

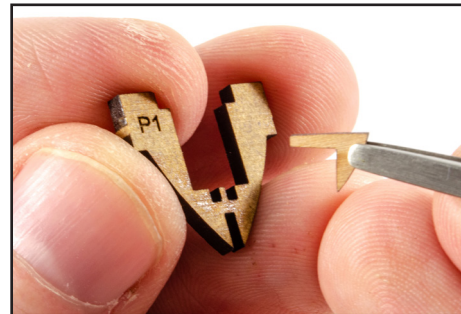

690. SHIPS BOATS – 28FT PINNACE: Glue the two Bow Planking Patterns (P-15) from the 1mm wood sheet to the Bulkhead (P1) from the 2mm MDF sheet.



691. When both P-15 are fitted, the assembly will look like this.

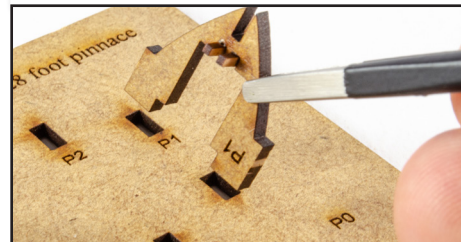

692. Fit all bulkheads into their corresponding slots on the 2mm MDF base.



693. Remove P12 from the 1mm wood sheet and sit it in its slot in the base. Again, do NOT glue.

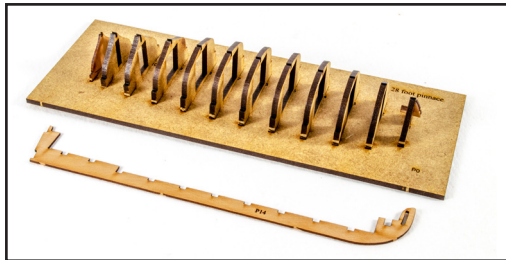

694. When all bulkheads are in position in the base, remove the Keel P-14 from the 1mm wood sheet.

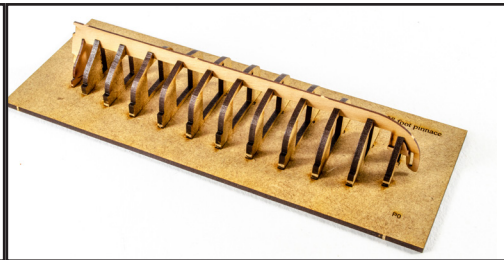

695. Glue the keel into the slots in each bulkhead. You may need to joggle the frames to get it to sit properly. Brush glue into the joints and leave the glue to thoroughly set before continuing.



702. As you continue to plank, you will need to taper each one. The pencil marks here show where I tapered mine from. You will also need at some point, to taper downwards from the keel. Don't worry about using stealer planks to fill gaps.



703. Trim back the shoulders of the MDF bulkheads as that will make it easier to sand the hull to shape.



696. Glue the stern board P13 from the 1mm wood sheet, into position as shown.



697. When P13 is glued into position, it should be at the same angle as the stern angle of the keel, and flush with it.



704. Sand the hull using 120 grade paper, finishing it with a finer grade to allow for a good paint finish.



705. When sanding the hull and achieving a good finish, you may need to use some filler. We recommend a good acrylic filler that you can dilute with water.



698. Use sandpaper or sanding sticks to sand/fair the bulkheads so that a plank will lie across them with maximum contact.



699. If you want to bend the first 0.6mm hull planks (P30), you can soak them but make sure they are thoroughly dry before fitting them.

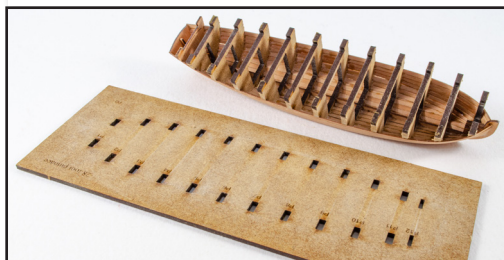

706. Remove the hull from the base. The base can now be discarded.

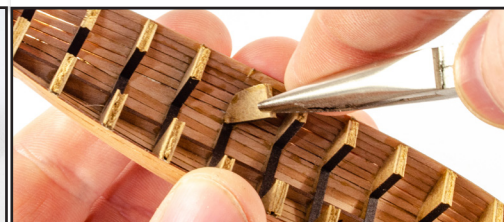

707. Use pliers to twist the MDF bulkheads to remove them. The lower section will remain in place.

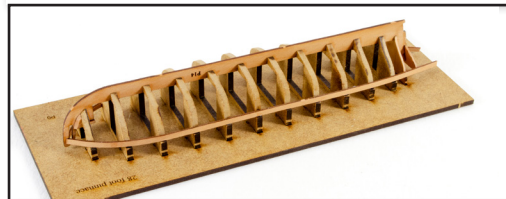

700. Fit the first plank as shown. This will sit on the shoulder of each bulkhead. We recommend using wood glue for planking, instead of CA.

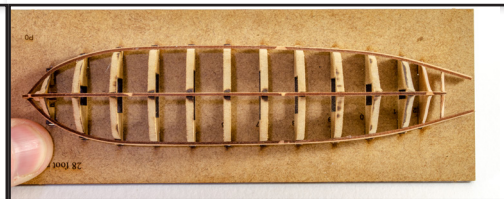

701. If you have faired the bulkheads correctly, your planks will lay across the bulkheads with maximum contact on each one.



708. Sand the inside of the hull smooth and remove any glue remnants. Remove the rib strips (P31) from the 0.6mm wood sheet and fit as seen here. Space them around 5 – 6mm apart.

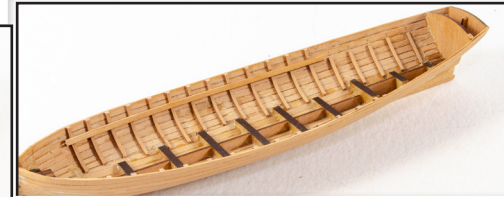

709. On the forward ribs, make a pencil mark 3mm down from the top bulwark edge. Cut the seat support strips (P32) from the 0.6mm wood sheet and glue into position below the pencil marks, as seen here.



710. **OPTIONAL:**
a. To create a wood finish to the PE floor sections, you can first apply a coat of Tamiya XF-59 Desert Yellow.



710. **OPTIONAL:**
b. On top of the paint, you can now apply a very thin coat of Raw Sienna oil paint using a piece of foam.



710. **OPTIONAL:**
c. Spots of Raw Umber oil paint can now be randomly applied to the previous oil paint covering.

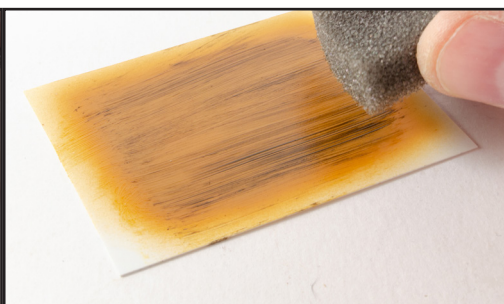

710. **OPTIONAL:**
d. Using your foam sponge, drag the dark oil spots into the lighter layer below. Keep doing this until you achieve the desired result.



710. **OPTIONAL:**
e. You can make your wood effect as subtle or as coarse as you wish.



710. **OPTIONAL:**
f. A fan brush can also be used to create knot effects and a more natural flow to the grain.

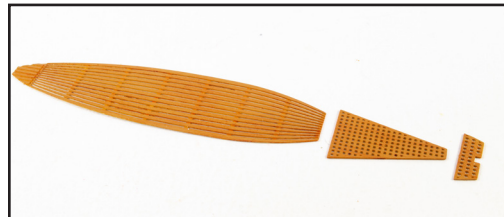

711. Once you have painted your photo-etch floor sections, set them aside and allow them to dry thoroughly. If you have used the oil paint method, set the parts aside for between 24 and 48hrs.



712. Glue the floor sections into place within the hull as shown. We recommend using CA for this.



713. From the 1mm wood sheet, glue parts P16 and P24 into position in the bow and rear of the boat.



714. From the 1mm wood sheet, glue the knees P25 into place as shown.



715. The seating can now be fitted, from the 1mm wood sheet. From the bow going aft, these are parts P18, P19, P20, P21, P22 and P23. From the 0.6mm wood sheet, you can also fit the knees (P26) between the seat end and the bulwarks.

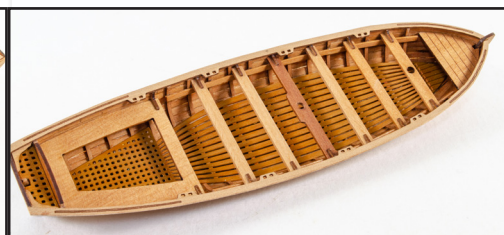

716. Glue the 0.6mm gunwales (P27) into position as shown. The engravings on these must face upwards.



717. Now fit the Fore and Aft Boards (P28, P29) from the 0.6mm wood sheet. These sit directly over the gunwale engravings.



718. Cut the rudder (P17) from the 1mm pear wood sheet and also remove the rudder side patterns from the 0.4mm boats PE sheet. Note that all parts for the Pinnacle are in the same area, and that applies to the Launch and Yawl too.



719. We recommend using CA gel to glue the PE parts to the wooden rudder as it gives time to allow for positioning.



720. Paint the hull white and the wales (from the planking strips) in black. Glue the wales into position as shown. The wales will simply follow the path of the second plank down, on each side.

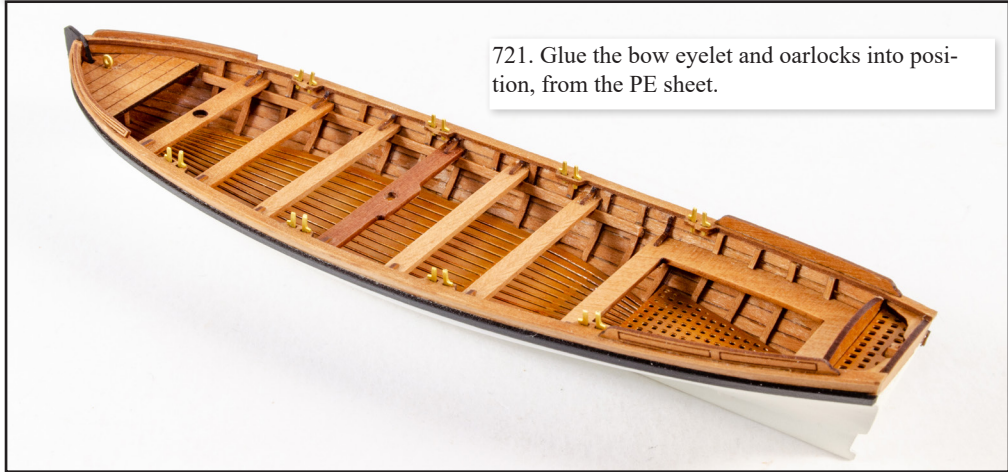

721. Glue the bow eyelet and oarlocks into position, from the PE sheet.



722. Glue the anchor parts together as shown, using CA. You can either paint these black or use a blackening solution.



723. Sand the paddle to shape and slightly round the handle. To paint, we suggest white for the handle and just a plain varnished paddle. The paddle tip can be painted copper.



724. Glue the rudder into position. We recommend CA for this.



725. We suggest you fit the oars as we have here. You can stow the anchors at the back of the boat and for the boat hooks, we've sat them as shown, towards the front. Paint the handles in brown and the hook in silver.

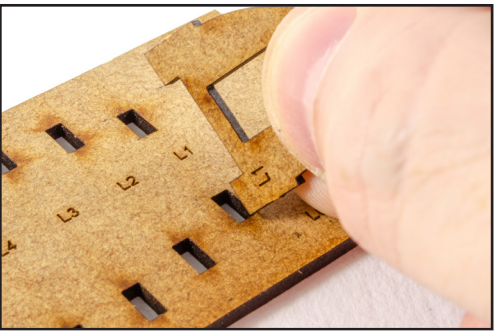

726. SHIPS BOATS – 24FT LAUNCH: Remove all parts from the 2mm MDF sheet and sit each bulkhead into its corresponding position on the base. Do NOT glue.

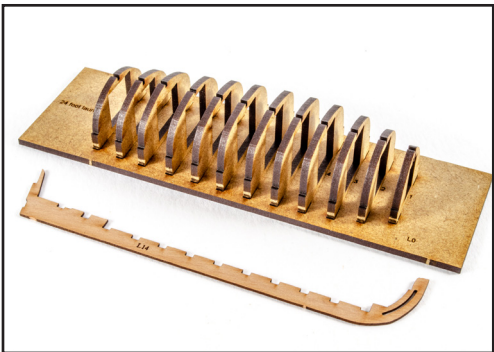

727. With all the bulkheads in position on the base, remove the keel (L14) from the 1mm wood sheet.

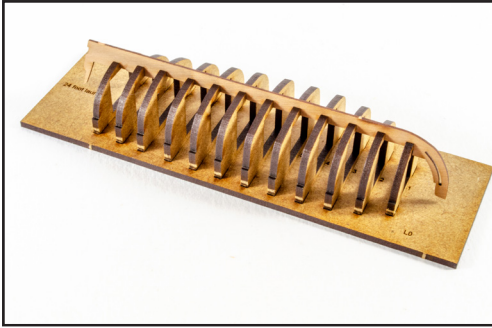

728. Sit the keel into the slots on each bulkhead. You may need to joggle things about to get it to sit. Once in position, brush wood glue into each joint and allow to thoroughly dry.

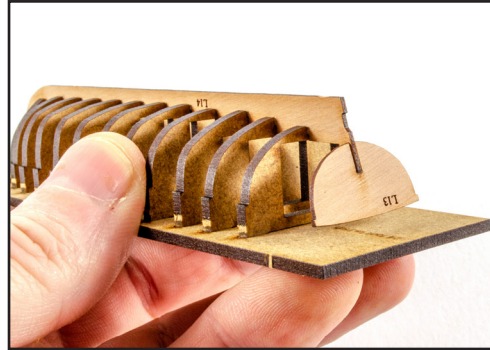

729. Remove the stern board (L13) from the 1mm wood sheet and glue into position on the keel, as shown here.

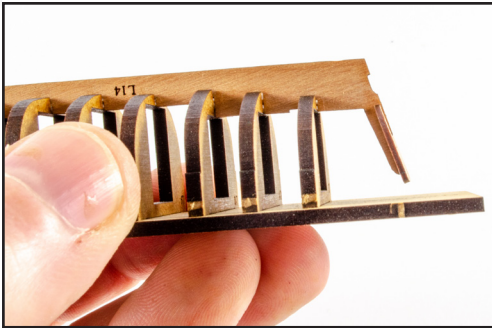

730. The stern board must slope at the same angle as the stern end and be flush with its outer edge.



731. Cut the two bow planking patterns (L15) from the 1mm wood sheet and bevel the forward edges on one side.



732. Glue the two parts into position on the keel, as shown here.

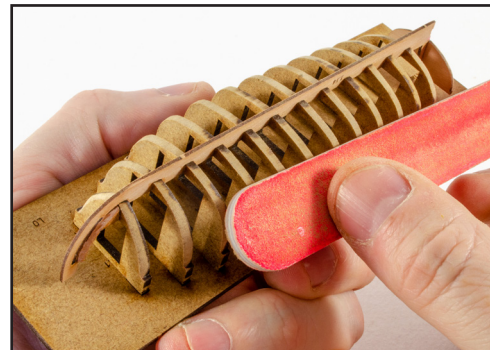

733. Sand/fair the bulkheads using sandpaper or sanding stick, so a plank will lie evenly over the bevelled bulkheads.



734. If you decide to soak the first planks to bend them, make sure you allow them to thoroughly dry before fitting them.

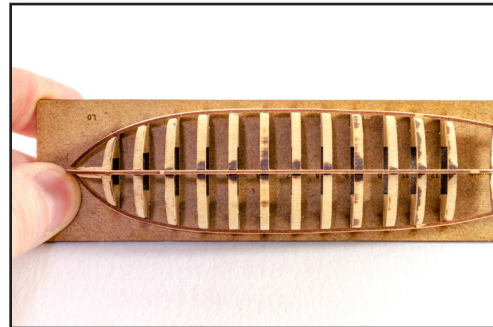

736. Note that due to the bevelling, the plank sits on the bulkheads with as much surface contact as possible.



735. Lie the first of the hull planks (L29) from the 0.6mm wood sheet, in place as shown. This sits against the shoulders of the MDF bulkheads. We advise using wood glue for this instead of CA.



737. Using more 0.6mm planks, continue to plank upwards towards the keel. To get maximum contact to the bulkheads, you will need to taper the planks. The pencil marks seen here are where these were tapered from. Edge-bevelling the planks will allow them to sit snugly together too. You will probably find it necessary to start planking from the keel at some point and meet up with the previous planking.



738. Here you can see the completed planking. It's perfectly ok to use infill planks (stealers) to close up any gaps, as these won't be seen below the paint layer. You can see the infill planks in this picture.



739. Sand the hull smooth using 110 grade abrasive paper to start with and then finishing with finer grades. We suggest any imperfections are filled with an acrylic filler, diluted with water.

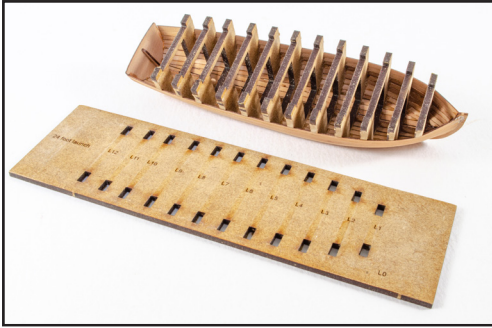

740. Remove the hull from the base. You can now discard the base part.



741. To remove the MDF bulkheads, first snip away the bridge on each one.

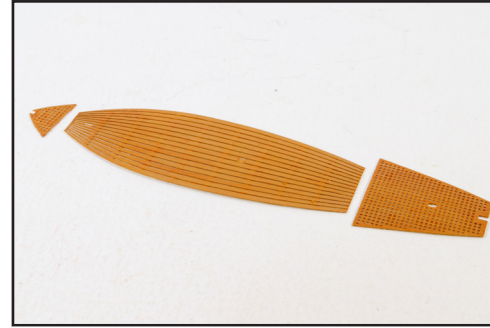

746. Now paint your PE floor sections.



747. Use CA to glue the sections into position as shown.



742. Use pliers to twist at each bulkhead to carefully remove them.



743. You can now use a sanding stick to draw over the upper edges of the bulwarks, to evenly level them.



748. Glue seat L27, Knees L24 and the bow bracket L28 into position as shown.



749. Starting at the bow, install seats L16, L17, L18, L19, L20, L21 and L22, as shown. Also fit the knees L32. Glue parts L26 into position.



744. Carefully sand the inside of the hull to smooth things out and remove a remnant of glue. Cut the rib strips (L30) from the 0.6mm wood sheet and glue into place inside the hull, as shown. Space these 5 – 6mm apart.



745. Use a pencil to make a mark on the ribs which is about 3mm down from the edge of the bulwark. Remove the seat support strips (L31) from the 0.6mm wood sheet, and glue underneath these pencil marks.



750. Mark a waterline on the hull and paint the lower area white. Take two planking strips and paint those black. Glue them into position so they are level with the upper bulwark. Bend and glue the mast support brackets into position and paint black. Also fit the eyebolt and paint black.

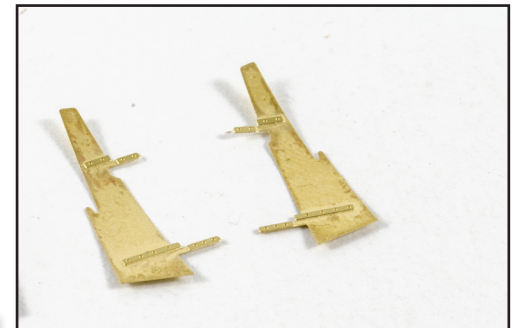

751. Cut the rudder (L23) from the 1mm wood sheet and also the rudder side patterns from the PE sheet. For this boat, you can remove the rudder tiller as there is a separate arm to be fitted within the boat. It's up to you.



as shown. We recommend using CA gel as this allows time to position the parts before the glue fully sets.



753. Use CA to glue the rudder into place and then part L25. L25 fits into the hole in the rear deck. Use more planking strip to add the upper bulwark sections, leaving gaps for the oarlocks.



754. Use CA to glue the anchor together, then paint black.



755. Sand the paddle to shape and slightly round the wooden handle. We suggest painting the handle in white and the paddle in bare varnished wood. Paint the paddle tip in copper.



756. Use CA to glue the rudder into position.



757. Glue the oars into position, and also the boat hooks. The latter should have wooden painted handles and metal tips.



758. SHIP'S BOATS – 22FT YAWL: Cut all parts from the 2mm MDF sheet and sit the bulkheads Y3 – Y9 into their corresponding slots on the base. Do NOT glue.



759. All bulkheads are numbered. Each one should now be dry fitted into the base as shown here. Cut Y-10 from the 0.6mm wood sheet and also sit this onto the base as shown. Again, do NOT glue.

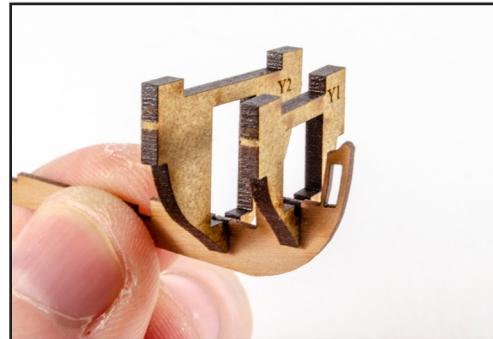

760. Sit bulkheads Y1 and Y2 on the 1mm keel (Y12). Do NOT glue.



761. Cut the two parts Y13 from the 1mm wood sheet and bevel the forward edges as shown.



762. Sit parts Y13 into position as shown. Note that these parts sit in slots Y1 and Y2. Glue Y13 to the keel but NOT to the bulkheads. The upper edges will align with the keel.

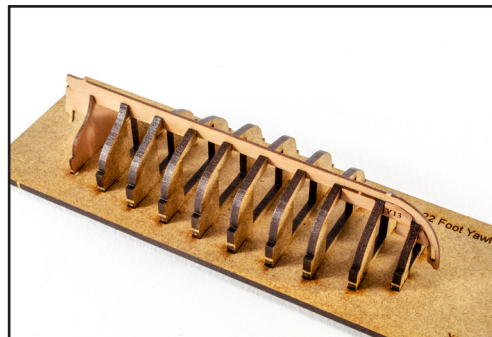

763. Sit the keel (Y12) into the slots in the boat's bulkheads. With this in place, brush some glue into the joints and leave to thoroughly dry.



768. Sand/fair the hull using sandpaper or a sanding stick. Take a plank to make sure it lies smoothly across all bevelled bulkheads.



769. The first planks can be soaked if you wish, but make sure you allow them to thoroughly dry before fitting to hull.

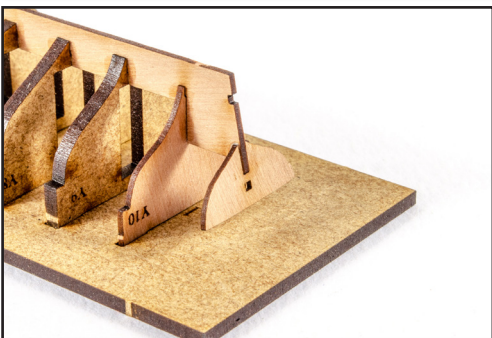

764. Cut the stern board (Y11) from the 1mm wood sheet. Glue into position on the keel.



765. This photo clearly shows the stern board in position. Note that it must be fitted flush and at an angle with the rear of the keel.

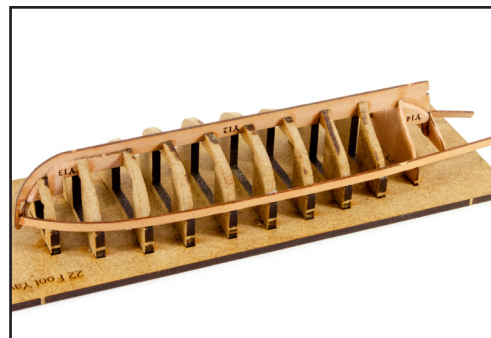

770. Glue the first 0.6mm plank (Y27) to the hull as shown, noting that it lies against the step on each bulkhead. We suggest using wood glue and not CA.

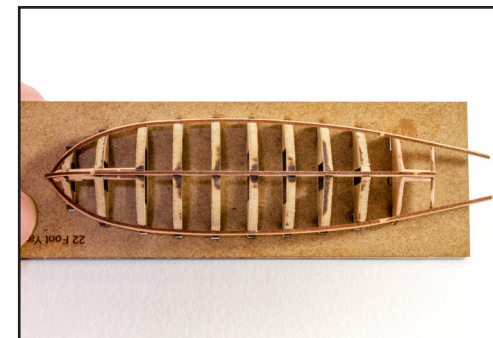

771. Here you can see how a plank is supposed to lie over the sanded/faired hull bulkheads. Aim for as much contact as you can between the plank and bulkheads.



766. Cut both parts Y14 from the 1mm wood sheet and bevel the outer curved edge as shown here. This bevel is only a rough guide as it will be bevelled more soon.

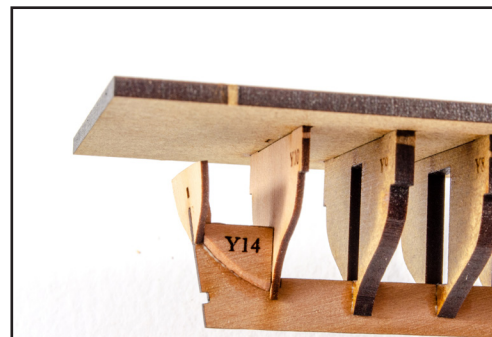

767. Glue the parts Y14 to the keel, between Y10 and Y11. To help with alignment, the upper straight edge is flush with the same area of the keel.

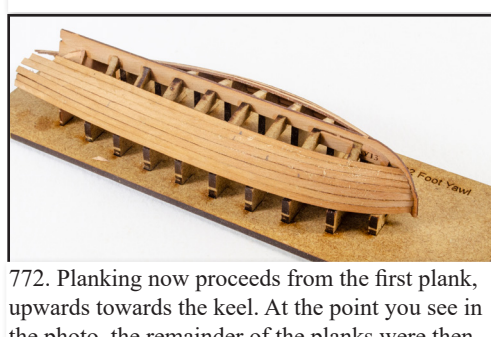

772. Planking now proceeds from the first plank, upwards towards the keel. At the point you see in the photo, the remainder of the planks were then fitted from the keel, down to the previous planks. You will need to taper your planking to make sure they sit against the bulkheads. The pencil marks you see are where I tapered them from, downwards the bow/stern.



773. You may need to fit infill planks or 'stealers' as you progress. We aim to make such fillers as low as possible in the hull so the paint will cover them. You may of course wish to use a tick-strip method to plank, whichever suits you.



774. Here's another view of the planked hull. Again, you can see the various taper marks and stealers that I fitted.



775. To help in sanding the hull, the protruding parts of the MDF bulkheads are cut away with a sharp knife.



780. When the bulkheads are removed, gently sand the internal walls and remove any glue deposits. From the 0.6mm wood sheet, remove the rib strips (Y28). Glue short lengths inside the hull at around 5 – 6 mm apart, as seen here.



781. On the forward ribs, use a pencil to add a mark 3mm down from the top of the bulwark. Cut the seat support strips (Y29) from the 0.6mm wood sheet. Add a strip to both the internal sides of the hull, as shown.



776. Sand the hull with around a 110 grade paper to begin with, using gradually finer grades to smooth the wood surface. Use an acrylic filler, slightly diluted, to fill any hollows or imperfections.

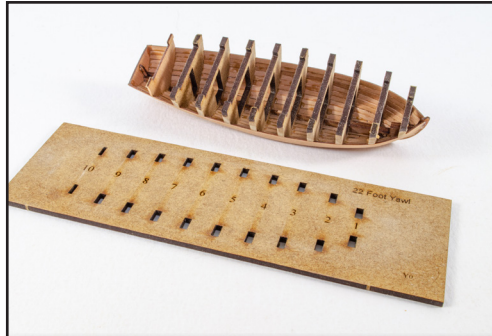

777. Carefully remove the boat hull from the base. The base can now be discarded.

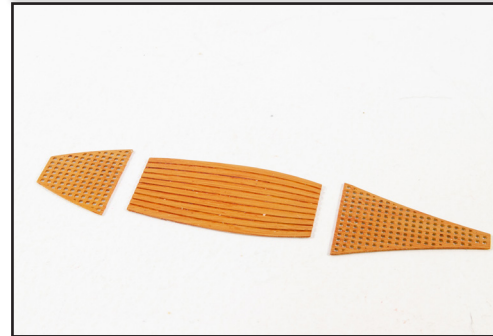

782. Once you have painted your photo-etch floor sections, set them aside and allow to dry.



783. Use CA to fit the floor sections into position inside the hull. Also fit Y22 into position in the rear of the boat, as shown.



778. To remove the MDF bulkheads, first snip away the small bridge on each part.



779. Now use pliers to carefully twist away the inner sides of the bulkhead. Remember, you will need to leave the section of MDF in the floor of your boat. Don't remove the wooden bulkhead near the stern.

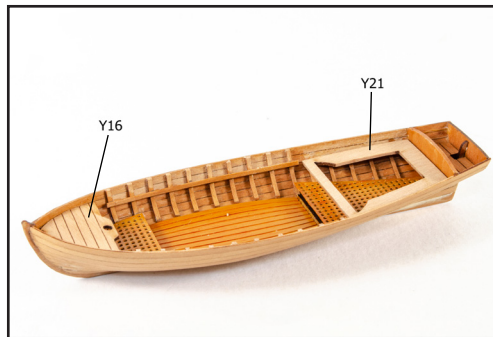

784. Glue parts Y16 and Y21, from the 1mm wood sheet, into position. You will need to bevel the underside edges to get a good fit.

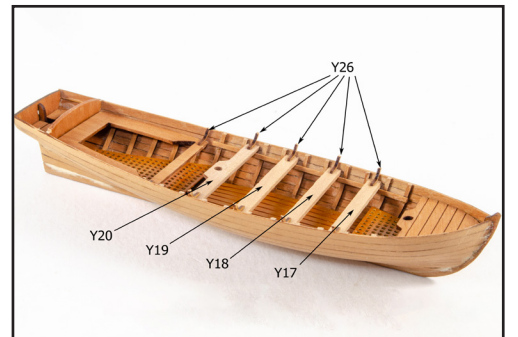

785. Glue the knees (Y26) into position, from the 0.6mm wood sheet.



786. Glue the gunwale sides (Y23) into position from the 0.6mm wood sheet, and when fitted, add the stern gunwale (Y30). The gunwales should protrude by around 0.5mm around the edge of the hull.



787. Glue the fore and aft boards (Y24, Y25) from the 0.6mm wood sheet, into position over the engraved position markers on the gunwales.



792. Glue the anchor parts together as shown, using CA. You can either paint these black or use a blackening solution to colour them.



793. Sand the paddle to shape it and slightly round the handle. Use white for the handles and natural varnished finish for the paddles. Paint the paddle tips in copper.

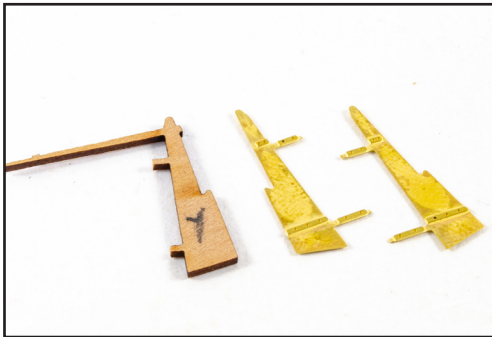

788. Cut the rudder (Y15) from the 1mm wood sheet and the rudder outer patterns from the PE sheet. Glue the parts together using CA gel. You can also mask the tiller arm to prevent it being sprayed white when the rudder is painted.



789. The finished rudder will look like this.



794. Glue the rudder in position using CA.



795. We suggest you glue the oars into position as shown. You may already have chosen to fit the rudder as stowed in the rear of the boat. Paint the boat hooks in brown for the handles and with a metal tip. Stow the anchor in your chosen position.



790. Paint the underside of the hull in white. Before fitting the wales (from the planking sheet), paint them black. When fully dry, glue the wales to the hull. These will fit directly over the plank below the top bulwark plank. Trim the wales at the stern so they are flush.

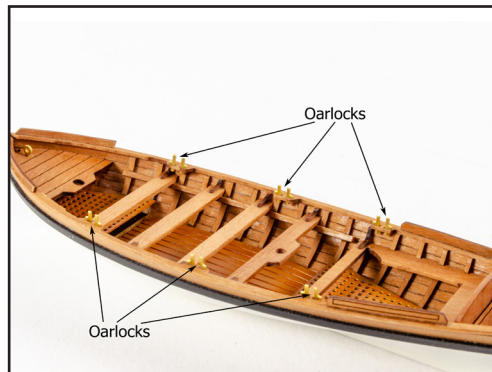

791. Glue the photo-etch oarlocks into place using CA. You may opt to paint these black beforehand.





796. Take two 46cm lengths of 3mm dowel and taper as per plan. Add a groove around these, towards the tapered end and drill the other end to accept a cut-off brass pin.



797. Install these boomkins as shown on plan, noting the angles they sit at.



798. Figurehead (F-1) and prime using a good quality fine surface primer, such as Tamiya. Paint the figurehead in gold paint and install to the ship's prow, as seen here. We recommend using Vallejo's Liquid Gold (Bright Gold) acrylic paint, mixed with a few drops of isopropyl alcohol to aid a nice finish and easy application.

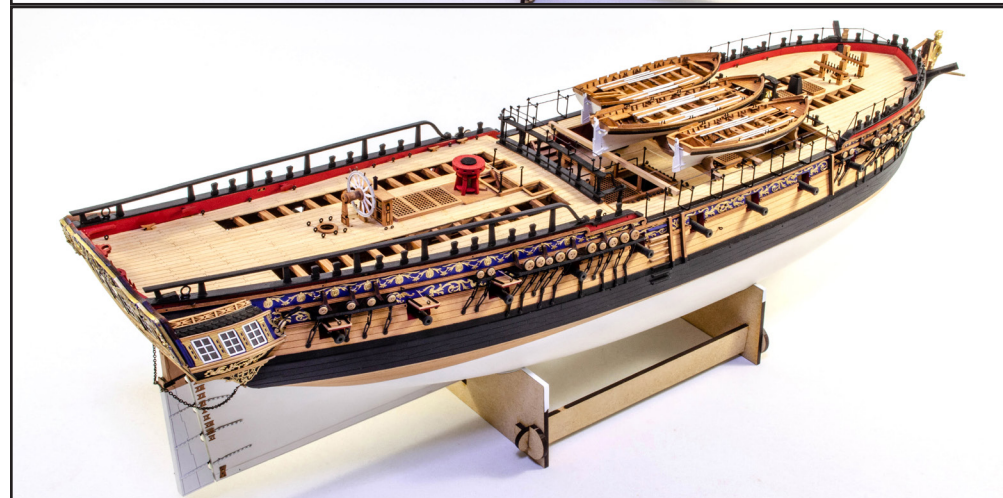

799. The finished hull will look like this. At this moment in time, the ship's boats and mounting beams are only dry fitted. Do not glue into position as it will impede rigging.





800. LANTERNS: Your Sphinx kit supplies parts to make two stern lanterns, printed in 3D. We will now build those and fit to the stern of the ship. These are the parts you will need to build the lanterns. You are advised to paint the lantern parts first. We suggest ochre for the cap and base, and white for the frame area.

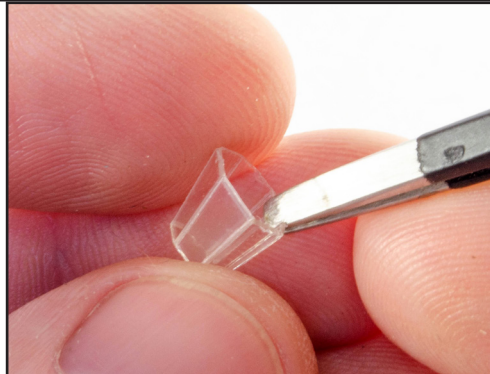

801. Peel the protective film from both sides of the glazing sheet (making sure it's removed from all individual panes), and bend to shape using tweezers. Make sure the engraving line is on the outside. Shaping doesn't have to be precise as it will push to shape in lantern body.

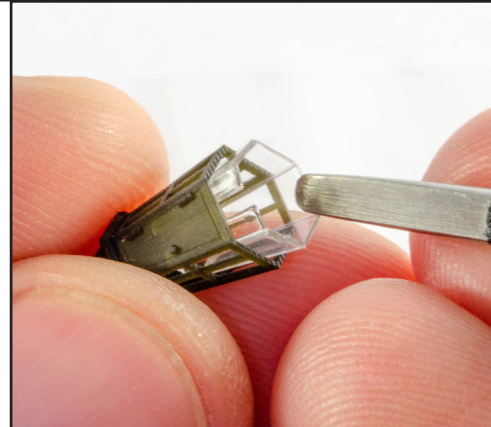

802. Insert the lantern glass into the lantern body and carefully push it all the way to the bottom so there's a slight recess at the top. If you struggle to get that recess, just snip a little from the top of the glazing.



803. Glue the lantern cap into place so the longest sloping side is against the rear of the lantern with the door.



804. Shape the brass rod so it matches the profile on the plans. Drill the base of the lantern with a 0.8mm drill to insert the brass mounting rod. Fit both lanterns as shown, with their slight tilt inboard. These mount into the holes you previously drilled from the inner stern bulwark.

MASTS AND YARDS



805. MIZZEN MAST: From the 1mm wood sheet, remove the Mizzen Top Platform (237) and the Mizzen Top Gunwale and Ribs (238).



806. Glue the two parts together as shown, using clamps around the edges to ensure a perfect fit.



807. From the 2mm wood sheet, remove the two Mizzen Cross Trees (416) and the Mizzen Cross Tree Chock (417). From the 1.5mm wood sheet, remove the two Mizzen Cross Trees (385) and the two Mizzen Cross Trees Bolsters (385a).

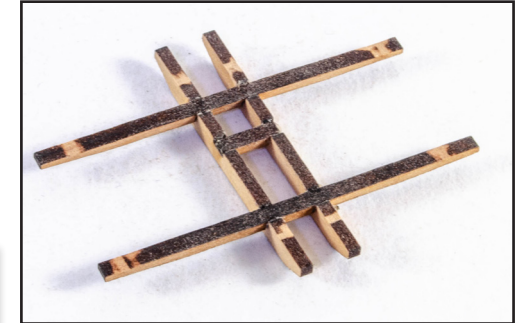

808. Assemble all parts (not the bolsters, yet), as seen here and on plan.

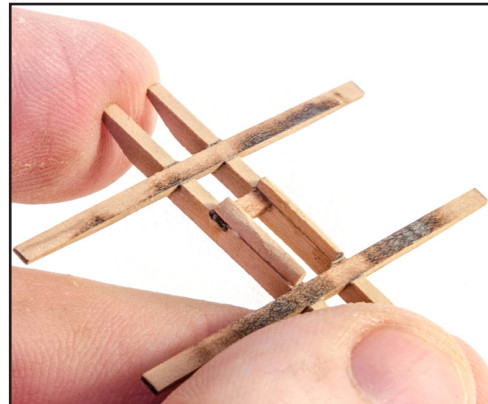

809. Sand the bolsters to shape as seen here and plan, and glue into position.



810. Glue the Cross Trees in place underneath the mizzen top platform and clamp until thoroughly set. Check plan for placement.

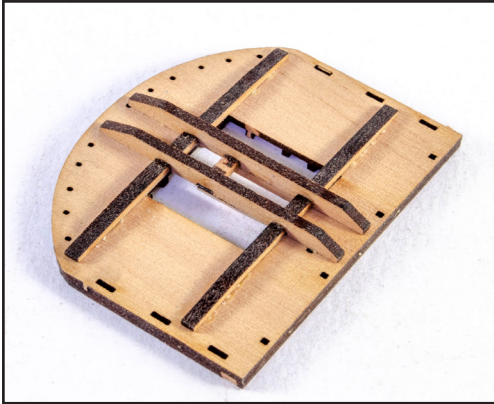

811. The completed assembly will look like this.

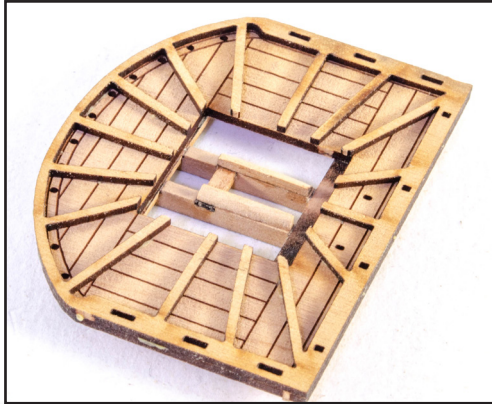

812. Using your plan as reference, cut the three mast sections from the appropriate dowel stock.



813. The mast sections will go through a number of shape changes to their cross section. Here you see the upper area of the lower section, squared-off on one side to fit the cross trees.



814. The upper section is then squared off on all sides and the top shaped to fit the cap block. You will need to reference the plans for the shaping of all mast sections for the sake of lengths and diameters. These photographs will just give you a general idea.



815. From the 1mm wood sheet, remove the left and right Mast Bibs (230, 231). Glue to the lower squared face you made on the dowel. Now slip the mizzen top platform into position and make sure it fits up to the mast bibs. **DRY FIT EVERYTHING FIRST!** You will note the mizzen top platform is slightly angled to counter the rake of the mast. Check against plans. When set, glue the Mizzen Mast Cap (470) from the 3mm wood sheet. Check alignment.



816. Use black cartridge paper, cut 1mm wide, to add the iron bands to the squared section of lower mast section. From the 0.6mm wood sheet, add the Mizzen mast Battens (134) as shown here and plan.

817. Now take the mast middle section (Mizzen Topmast) and shape as per plan. Drill the hole for the 'fid'.



818. Slide the mast section through the mast cap, then insert and glue the Mizzen Topmast Fid (242) from the 1mm wood sheet.

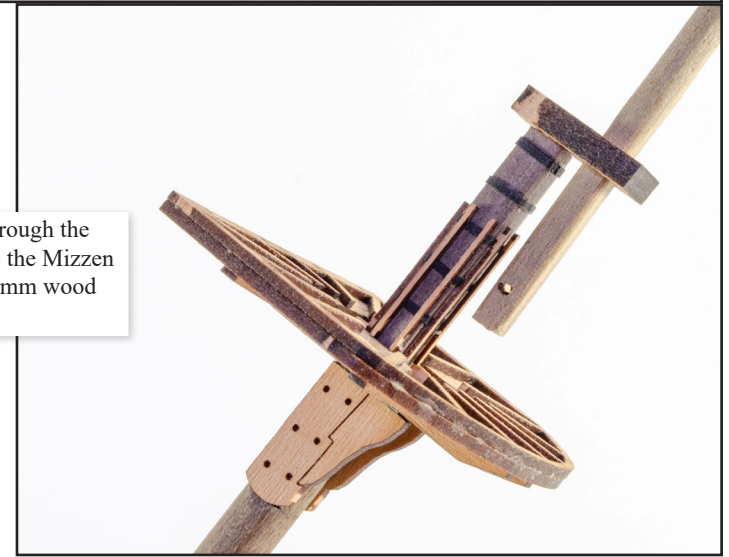

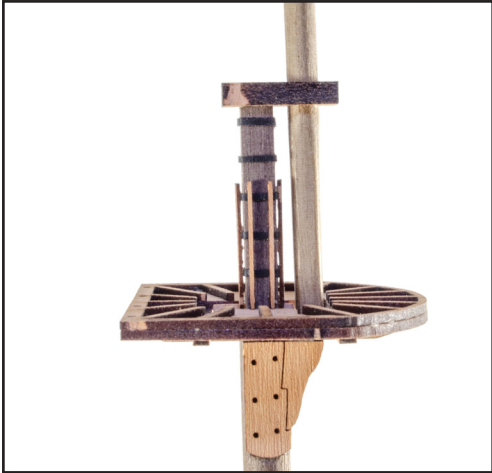

819. Seat the mast section as shown, also gluing within the cap block.

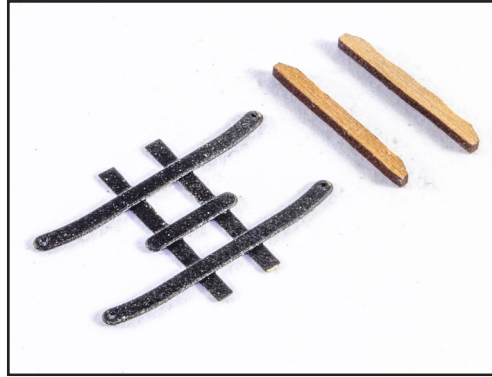

820. From the 1mm wood sheet, remove the two Mizzen Topmast Trestle Trees (241). From the 0.4mm PE sheet, remove the 0.4mm PE sheet, remove the Mizzen Topmast Cross Tree Pattern (PE-64).



821. Glue the trestle trees into position on the underside (the surface with no details) using CA glue.



822. Glue the cross tree into position as shown. You can now also glue the Mizzen Topmast Cap (422) into place, from the 2mm wood sheet.

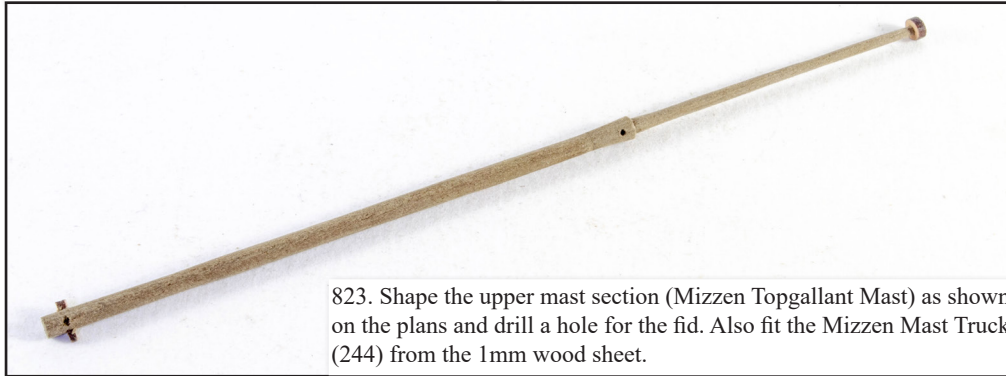

823. Shape the upper mast section (Mizzen Topgallant Mast) as shown on the plans and drill a hole for the fid. Also fit the Mizzen Mast Truck (244) from the 1mm wood sheet.

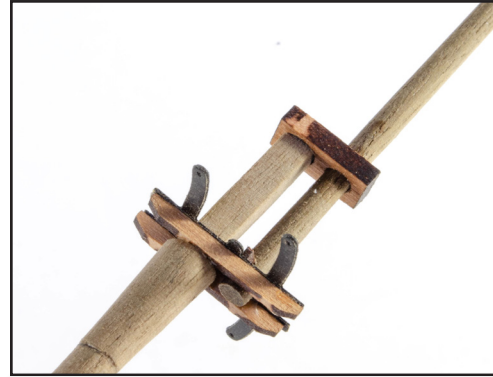

824. Slide the mast section through the cap block and glue the Fid (243) from the 1mm wood sheet. Glue the mast section into place in the cap block and where the fit rests on the cross trees.



826. From the 1mm wood sheet, glue the Mizzen Belaying Pin Ring (246). You can now paint the belaying pins (PE-152) from the 0.4mm PE sheet, and fit them into the holes.

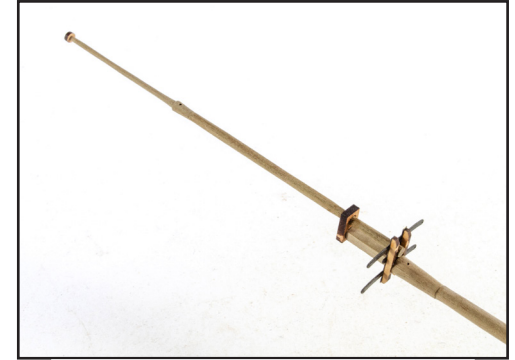

825. The upper section will look like this.



827. MAIN MAST: From the 2mm wood sheet, remove the two Main Trestle Tree parts (420), two Main Shroud Bolsters (418), and a Main Cross Tree Chock (419). From the 3mm wood sheet, remove the two Main Cross Trees (453).

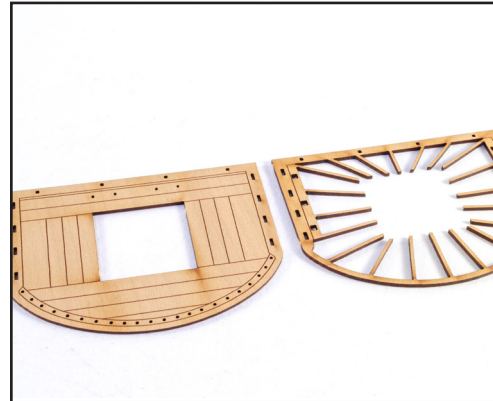

828. Assemble the cross trees as shown. Also shape and glue the bolsters as with the mizzen mast.



829. From the 1mm wood sheet, remove the Main Top Platform (227) and the Main Top Gunwale and Ribs (228).

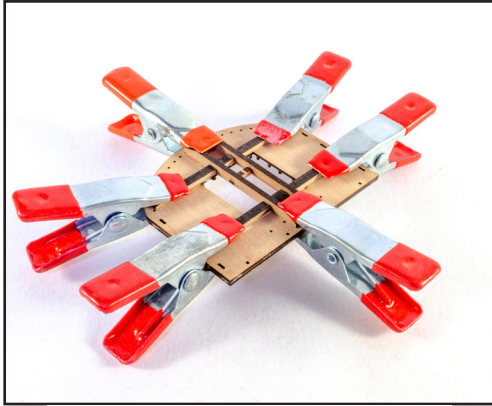

830. Glue and clamp the parts together.

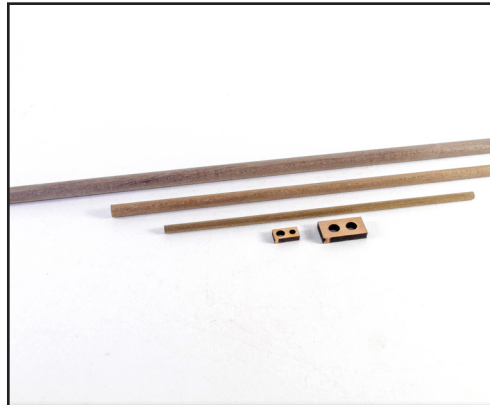

831. Glue and clamp the cross trees to the underside of the platform and when dry, set to one side.



834. The 8mm dowel is then laid across the bolts and 1mm of the dowel will sit above the surface. The jig is then clamped in a vice and the protruding dowel sanded flush with the surface. To do the same for the opposite side, I just added some 1mm packing over the bolts before sitting the dowel in the jig again.

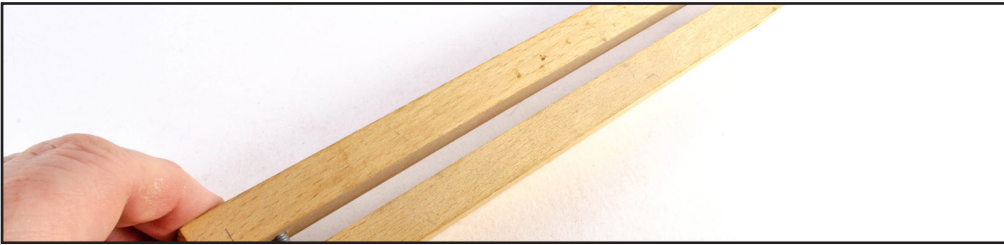

832. Cut the three sections for the main mast, using your plans for dimensions. Also remove the Main Mast Cap (473) from the 4mm wood sheet, and the Main Top Mast Cap (471) from the 3mm wood sheet.

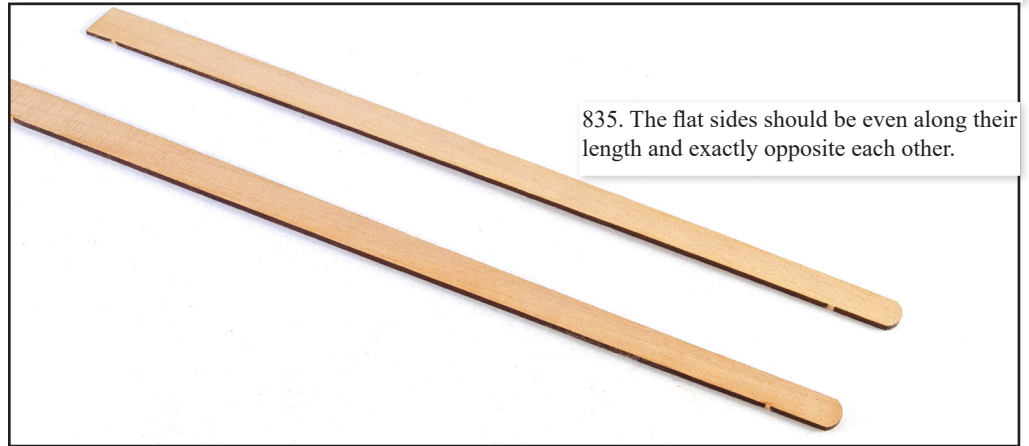

835. The flat sides should be even along their length and exactly opposite each other.



833. There are numerous ways to create the long flat sides on the lower mast section. Here is a jig that was built to do this. Two beams of birch are placed together, and two holes drilled through which are exactly 7mm from the top flat surfaces. Bolts are then inserted, being glued into one half.

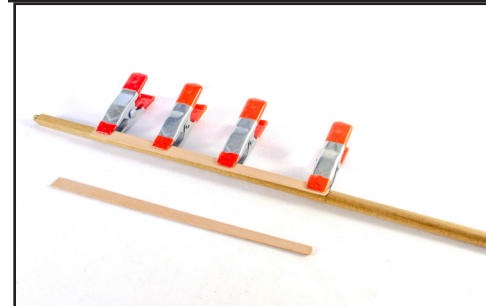

836. From the 1mm wood sheet, remove the two Main Mast Cheeks (229).

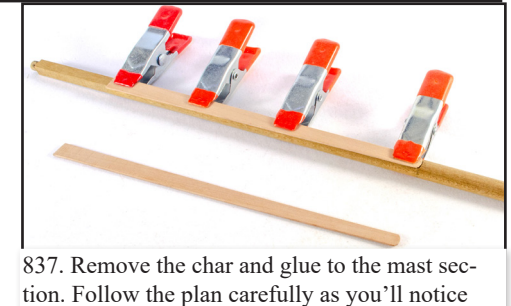

837. Remove the char and glue to the mast section. Follow the plan carefully as you'll notice the tops of the cheeks are slightly angled to cater to the rake of the mast, so the platform will sit horizontal to the waterline.

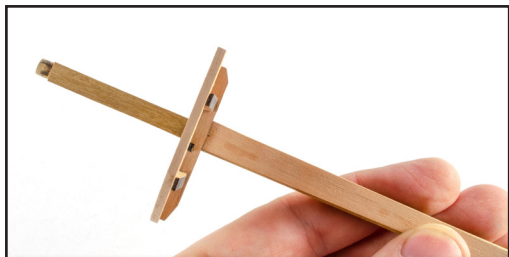

838. Here you can see the platform in position with a side image showing the slight angle of the platform.

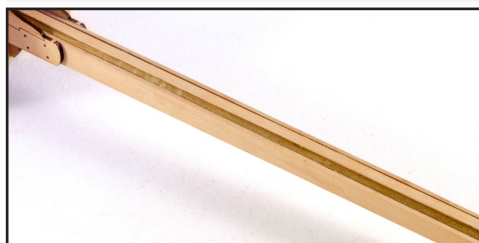

839. From the 1mm wood sheet, remove the two Main Mast Bibs – Left/Right (230,231).

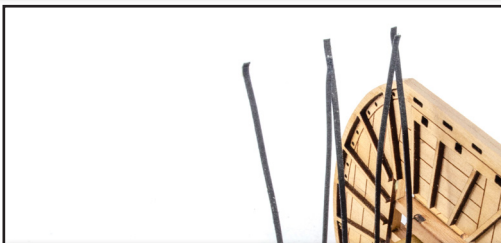

840. Glue these into place as shown, against the mast cheeks and underneath the cross trees.



841. Cut some 1mm wide strips of black cartridge paper and glue them into place to represent the iron bands.



842. From the 0.6mm wood sheet, remove the Main Mast Battens (133) and glue into place. You can now also fit the Main Top Mast Cap.

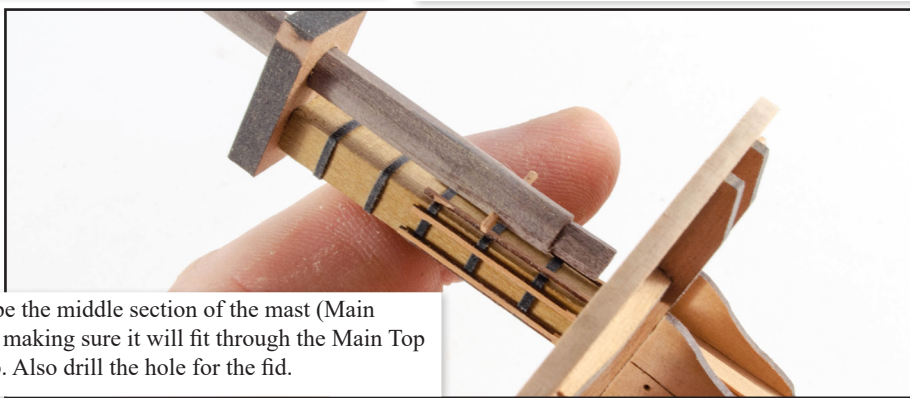

843. Shape the middle section of the mast (Main Topmast), making sure it will fit through the Main Top Mast Cap. Also drill the hole for the fid.



844. Slide the mast section through the mast cap and then glue the Fid (233) from the 1mm wood sheet.

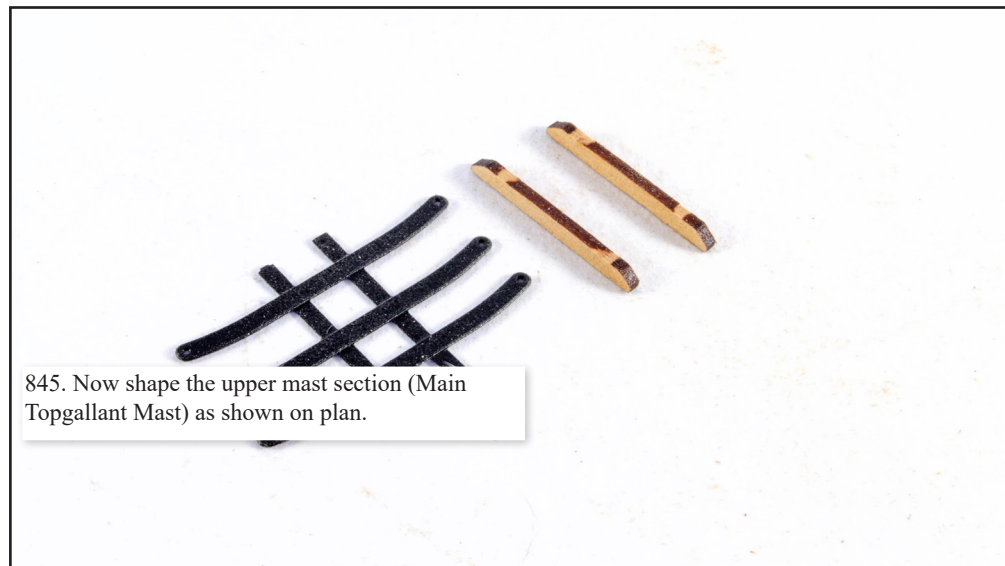

845. Now shape the upper mast section (Main Topgallant Mast) as shown on plan.



846. From the 0.4mm PE sheet, remove the Main Topmast Cross Tree Pattern (PE-65). From the 1mm wood sheet, remove the two Main Topmast Trestle Trees (232).

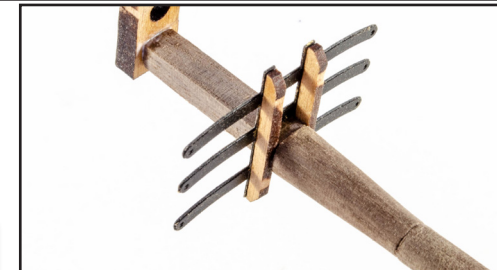

847. Glue the trestle trees into place on the underside of the cross tree.

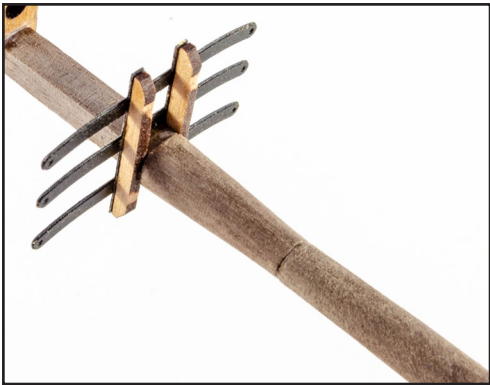

848. Glue the finished assembly into place on the mast mid-section and also fit the main topmast cap.

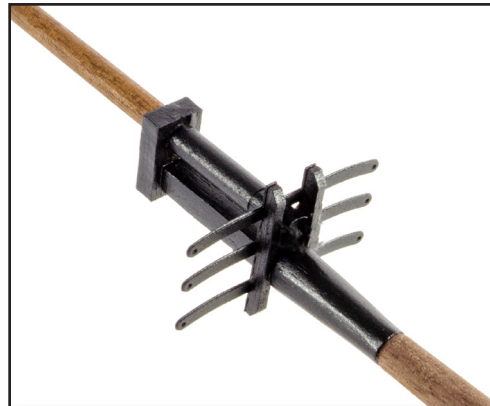

849. Fit the upper mast section as with the mizzen, making sure all is in alignment.

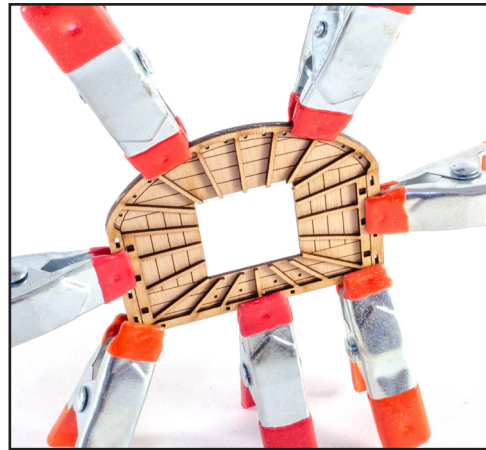

853. Glue together and clamp as shown.

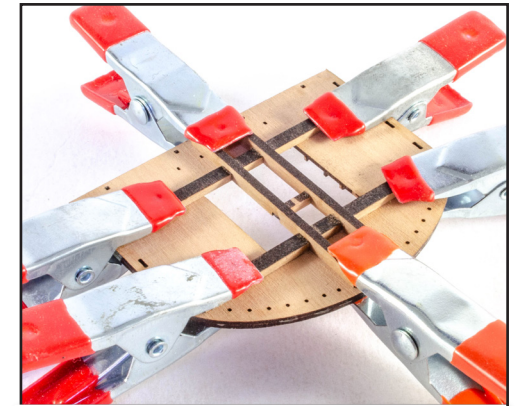

854. Glue the cross trees into position and clamp until set.

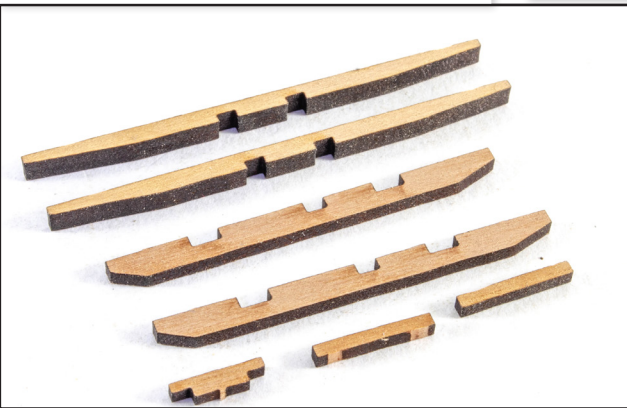

850. FOREMAST: From the 2mm wood sheet, remove the two Fore Trestle Trees (421) the two Fore Cross Tree Chocks (419). From the 3mm wood sheet, remove the two Fore Cross Trees (454)

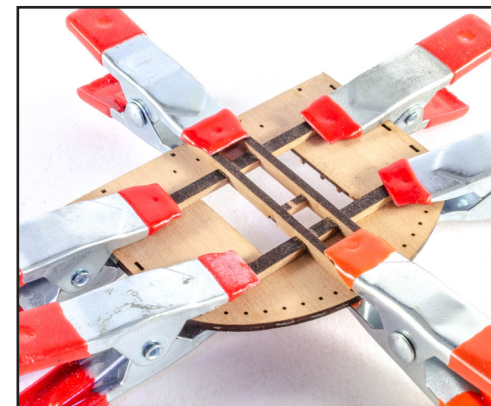

854. Glue the cross trees into position and clamp until set.



855. Create the flats on the lower mast section, taking dimensions from the plans. Also create a subtle flat running down the front of the mast, as shown on plan.



851. Assemble as shown. You can also shape the bolsters and glue them into position as on the other masts.

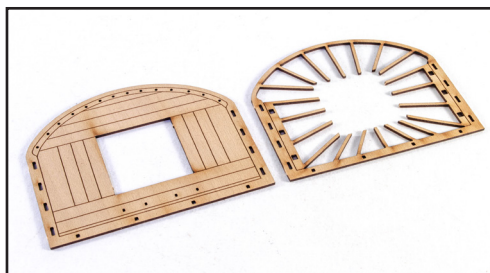

852. From the 1mm wood sheet, remove the Fore Top Platform (217) and the Fore Top Gunwale and Ribs (218).



856. From the 0.6mm wood sheet, remove the Fore mast Front Fish (92). From the 1mm wood sheet, remove the two Fore Mast Checks (219).

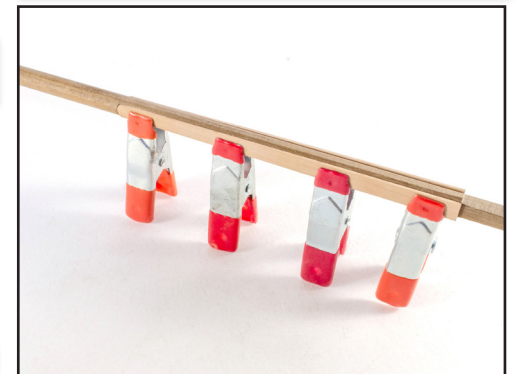

857. Glue the checks to the mast. Please note that the top of these is horizontal as the platform will be mounted horizontally.

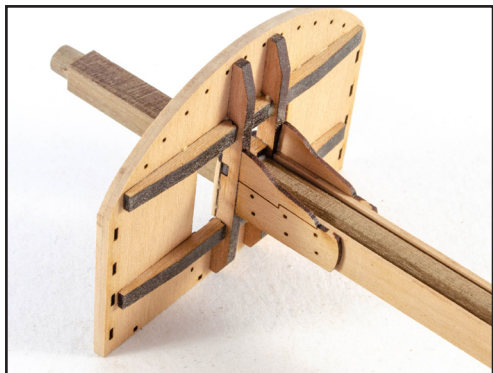

858. Glue the platform into place and also the Fore Mast Bibs – Left/Right (220, 221).

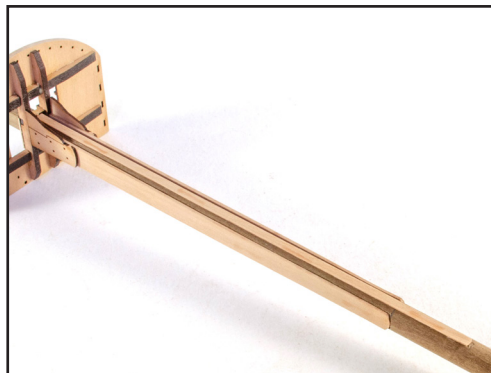

859. Glue the Front Fish into place on the front of the mast.

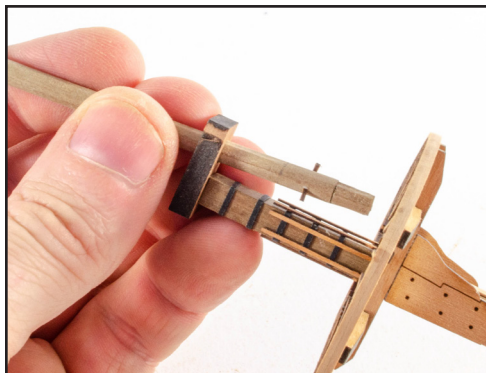

863. Slide the mast section through the mast cap, insert the Fid (223) from the 1mm wood sheet, and then glue into position.

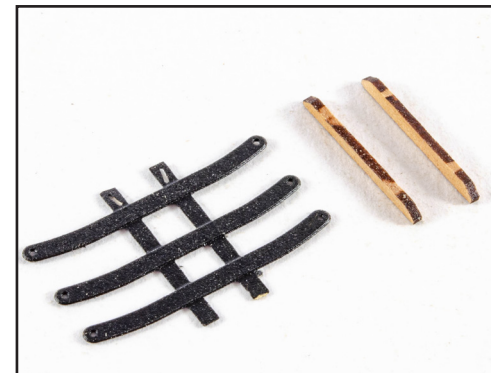

864. From the 0.4mm PE sheet, remove the Fore Mast Cross Trees (PE-66). From the 1mm wood sheet, remove the two Fore Topmast Trestle Tree (222).



860. As before, use 1mm strips of black paper to create the iron bands...



861. ...and then add the Fore Mast Battens (132). You can also now fit the Fore Mast Cap (475) from the 4mm wood sheet.



865. Assemble the cross trees like this, gluing the wooden parts to the underside of the PE.

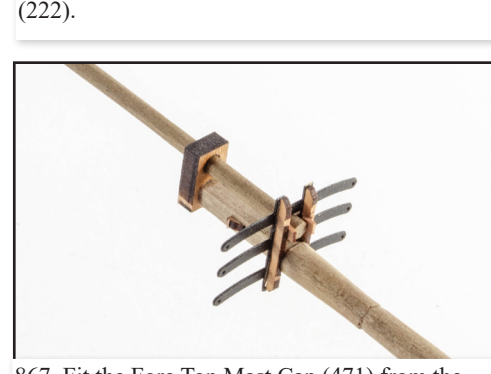

867. Fit the Fore Top Mast Cap (471) from the 3mm wood sheet. Slide the mast section through the cap and insert the Fid (224) into it, from the 1mm wood sheet. Glue the mast section into place.

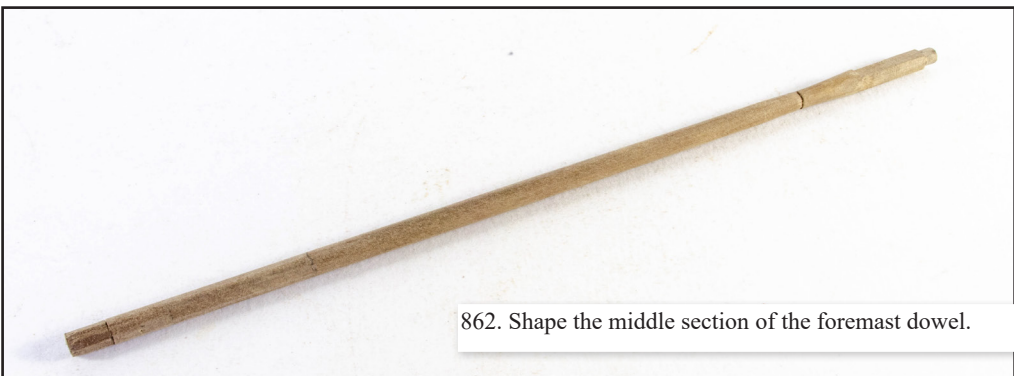

862. Shape the middle section of the foremast dowel.



866. Shape the upper mast section as per plan.



868. Fit the appropriate cleats and eyelets to the masts and then add the Lower Top Rail Stanchions to each, plus the appropriate Main Top Rail (226, 236 and 245) from the 1mm wood sheet. Mask and paint the mast sections in black before adding the various rigging blocks, iron bands and wolding (cord wraps) to the masts. It is advised that you use the method shown to fit the latter as you can then adjust them easily before varnishing.



869. BOWSPRIT: cut the two dowel sections needed for the bowsprit. From the 4mm wood sheet, remove the Bowsprit Cap (474). From the 1mm wood sheet, remove the Bowsprit Bee (247).



870. Use your plans to carefully mark where you will need to shape the front of the larger dowel, so the bee and cap can be fitted.



871. Carefully shape the dowel so that the bee will sit flush with the top of the dowel. Shape the front of the dowel at an angle to fit the cap.



872. Test fit the cap to make sure of a good fit, and make sure the dowel is then sanded flush with the front of the cap.

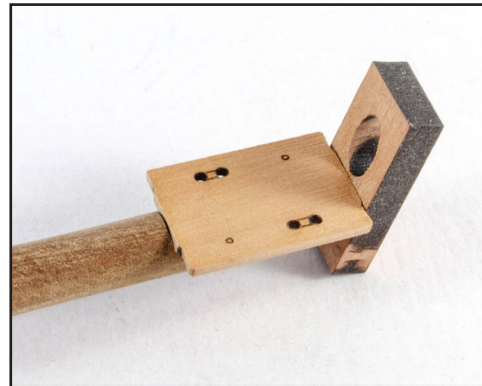

873. Now fit the bee. You will need to very slightly bevel the forward edge, so it sits against the cap. Also fit the Jibboom Saddle (249) from the 1mm wood sheet.

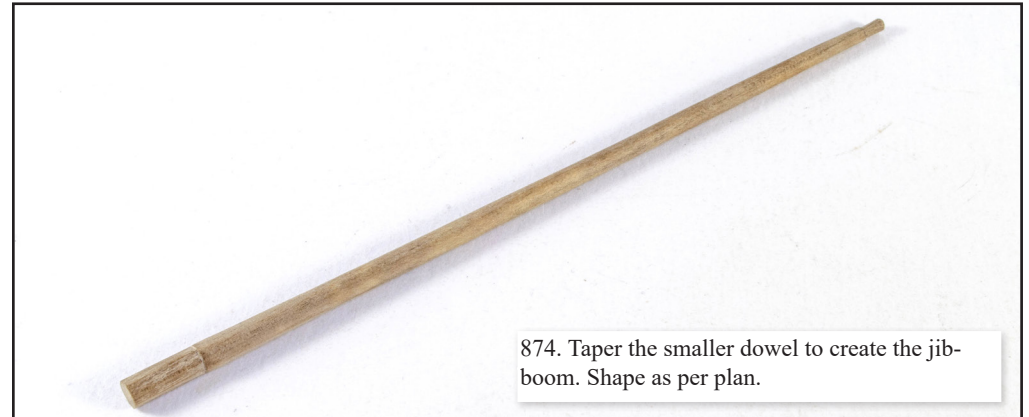

874. Taper the smaller dowel to create the jibboom. Shape as per plan.



875. Glue the jibboom into place. You will need to elongate the hole in the cap to pass the jibboom through. Use filler to fill any gaps afterwards. Also now fit the Bowsprit Fairlead (248) from the 1mm wood sheet. From the 1.5mm wood sheet, fit the Bowsprit Gammoning Cleats (393), and the Lower Yard Outer Cleats (396). With the gammoning cleats, you can temporarily fit the bowsprit to make sure you arrange these so they lie in a line with where the gammoning will wrap.

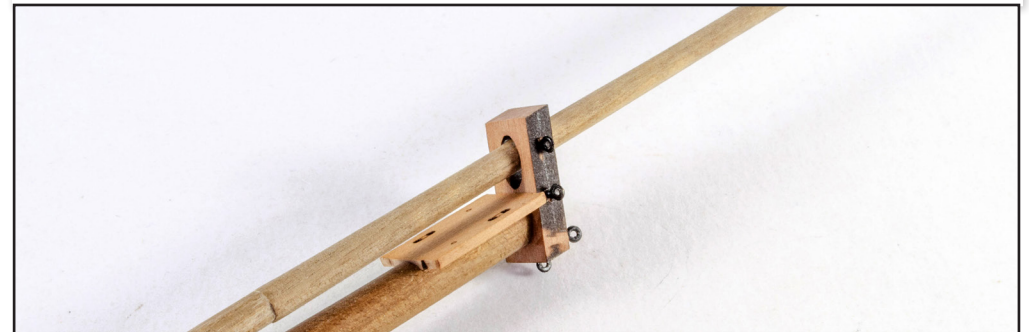

876. Fit the eyelets to the cap as shown, and also bevel the upper and lower sides of the cap so they are horizontal to the dowel sides.



877. Paint and varnish the bowsprit as shown and then fit the correct rigging blocks to it, as per plan.



878. Glue bowsprit into position at bow, making sure the orientation is correct and it runs perfectly in line from bow to stern.



879. Rig the bowsprit shrouds and stays as per plan. You can also rig the boomkins at this stage while things are accessible.



880. YARDS, GAFF etc: Make up all yards as per plans and don't forget the spritsail yards on the Mizzen/Bowsprit plan sheet. You can use either a cut-off brass pin to secure the yards to the masts, or brass wire. For the prototype, we have used the thicker wire option.

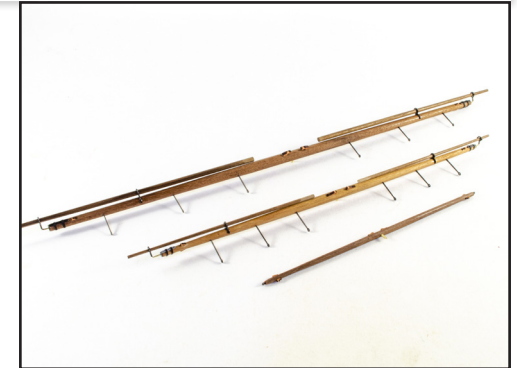

881. Paint all yards in black and fit them out with blocks etc. as shown on plans.

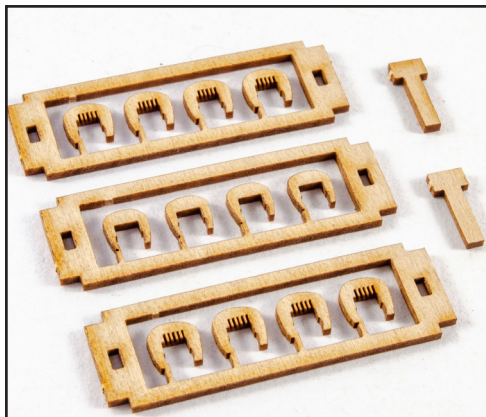

882. MAKING BLOCKS: Each set of open or closed heart blocks assembles in the same way. Take a full set of parts, including the two keys.

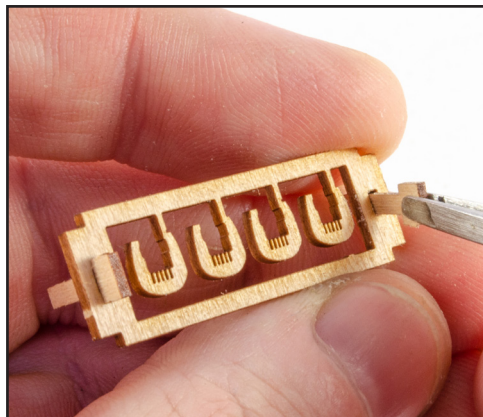

883. Two of the parts sprues have engraved marks. These are to go to the outside. Insert the keys into one of the sprues as shown.

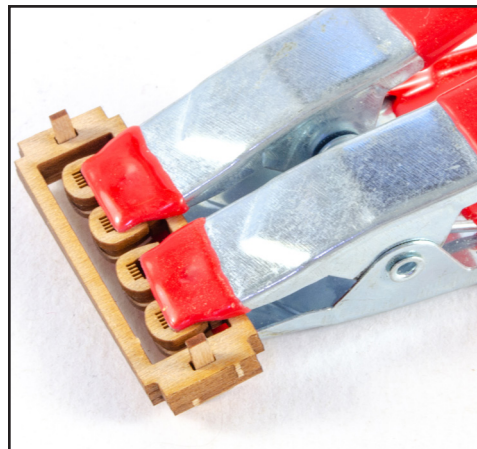

888. Clamp the parts until dry.

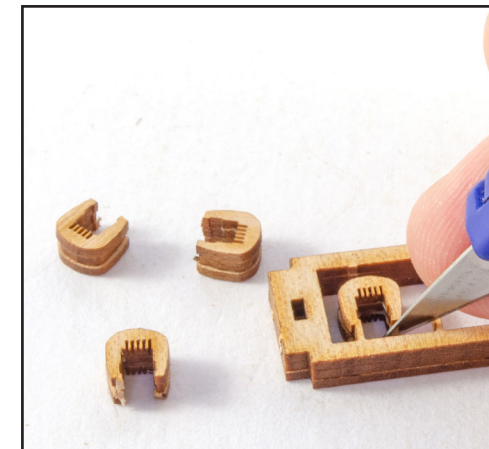

889. Remove the alignment keys and place parts flat on a desk. Cut through the tags to remove the parts. You should also not remove the char from the outside edges. It doesn't matter about the middle later as the rope will cover this.



884. Take the sprue with no engravings. These parts are slightly smaller in size. Glue into position over the previous, using the keys to align.



885. Here you can see these parts are slightly smaller.



890. MAIN STAY COLLAR: Before any further rigging, the main stay collar needs to be fitted. Take one of your assembled 5.8mm open heart blocks and rig as shown with 0.5mm black thread. Also use some smaller thread to bind each side to the larger cord.



891. Slot the rigging cord through the round holes in the bow grate and then through the hole in the bow knee. You can seize both ends of this together (either above or below the grate, so the block is in the position shown on the plan. This can also be seen on Plan Sheet 21.

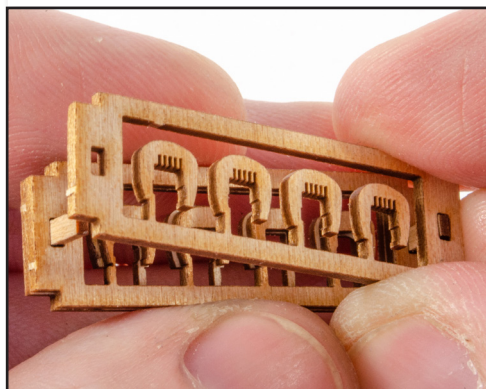

886. Now glue the last sprue with engravings into place, making sure the engraved face is outwards.



887. The block set will look like this.

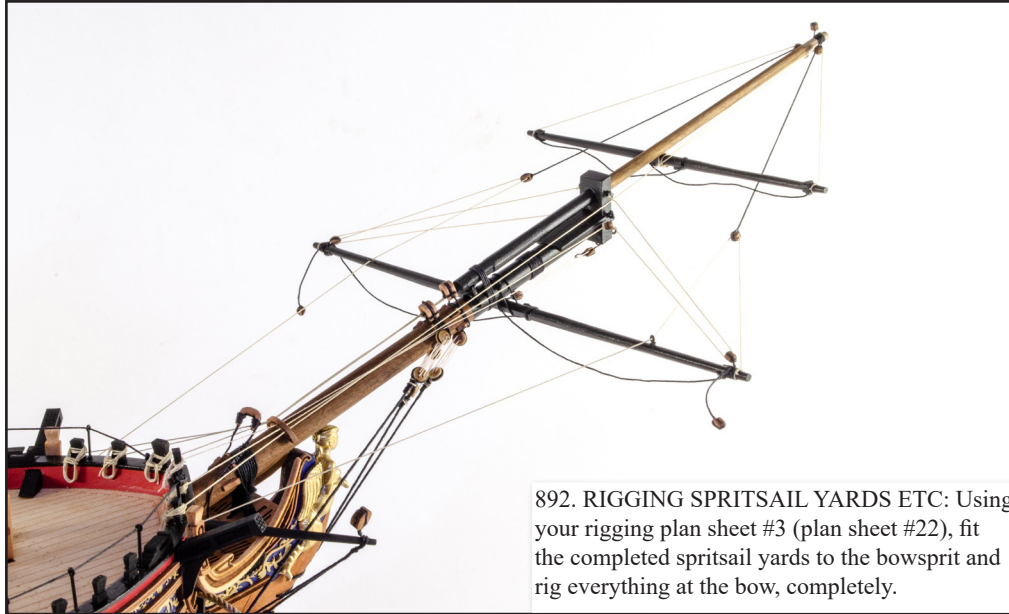

892. RIGGING SPRITSAIL YARDS ETC: Using your rigging plan sheet #3 (plan sheet #22), fit the completed spritsail yards to the bowsprit and rig everything at the bow, completely.

893. FITTING THE MASTS: This is quite simple, but vital you very everything properly aligned. Things should be aligned nigh on perfectly anyway, but if you need to make any adjustments to the central path of the masts, do so with a small file to the mast opening in deck, and preferably to the hole on the main deck so you don't elongate the mast base parts.



894. Before fitting the lower shroud lines, add the pendants to all three masts, using the thimbles. Check the plan for rope and thimble sizes as they vary between the fore/main to the mizzen.





895. From the 0.4mm PE sheet, remove the four Fore and Main Channel Stunsail Boom Brackets (PE-68). From the 0.6mm PE sheet, remove the four Fore and Main Channel Boom Irons. Paint these black. Fit these to the channels as shown on Plan Sheet #14.

896. RIGGING: For rigging, refer to the four rigging plan sheets. This will begin by adding the pendants and lower shroud lines to the lower mast tops and then seizing the deadeyes to the shroud lines. Ensure that the shroud deadeyes are around the same height from the channel deadeyes as you can make them. Ensure that all seizings are very similar too in execution. You will always find your own way of rigging, but after fitting the shrouds, we then suggest you fit the yards, then rig the mast stays, backstays, and then onto rigging the yards. Please work thoughtfully through the drawings, taking into account access to rigging points. When you know you won't be hindered, fit the ship's boats into position, lashing them down onto the cradles.

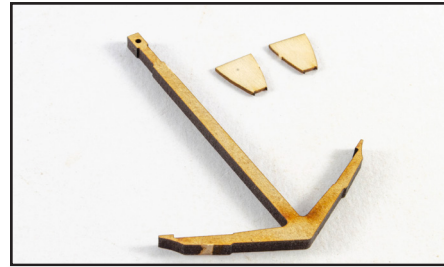

897. ANCHORS: From the 3mm MDF sheet, remove the four Bower Anchors (38). From the 0.8mm Ply sheet, remove the eight Anchor Flukes (52).



898. Glue the anchor flukes to the anchors as shown here, noting orientation.



899. Paint the assemblies black. We advise you mask the portion which will glue into the stock.



900. From the 0.6mm wood sheet, remove the Anchor Stock Side Patterns (114, 115). From the 2mm wood sheet, remove the eight Anchor Stocks (483).



901. Glue each anchor stock side pattern to the relevant anchor stock, as shown. Note that the stock has an engraved centre into which the anchor will sit.



902. Glue the stocks to the anchor as shown, and clamp until set. Note the angled side of the stock faces towards the anchor. When set, sand the char from the stocks.



903. Cut some black cartridge paper into strips of just over 1mm and glue them into position on the stocks, to represent iron banding. The stocks are engraved with the positions of the straps.

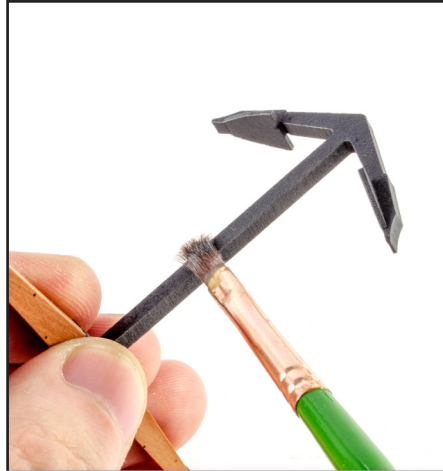

904. You can use some metallic (iron) pigment to make the anchors very slightly metallic around edges where the paint would weather in real life.

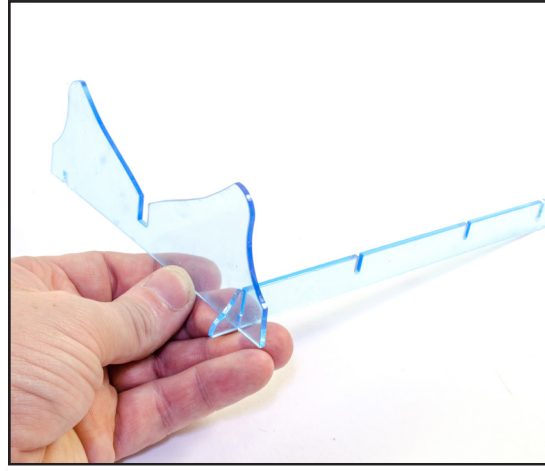

907. ACRYLIC CRADLE: It's finally time to ditch the MDF building cradle for the final display stand. Please note that you MUST remove the blue film from the reverse of the sheet before work begins. I've left this on to make the photographs clearer. For glue, you can use an acrylic adhesive such as Tensol, or a clear epoxy/ odourless CA. From the acrylic sheet, remove the fore and aft cradles (484, 485), and the two cross supports (487). Slot one support into one of the cradles as shown.

908. Now complete the basic cradle by joining the cradles with the cross supports.

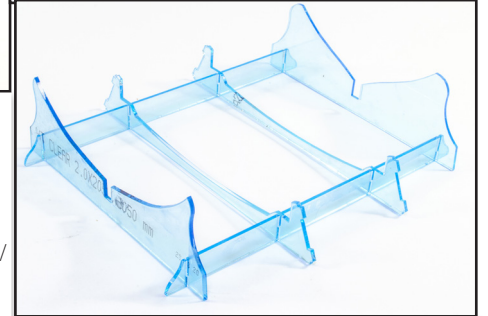
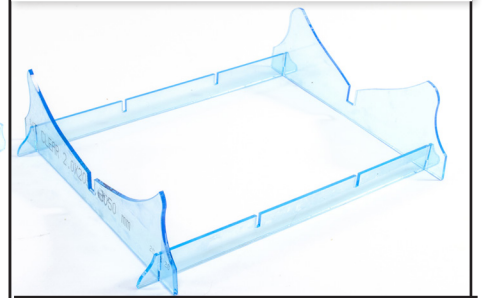

909. Fit the two nameplate cross supports (486) into place.



905. Use some brass wire to form the anchor hoops. Fit these to the anchors and paint black.



906. Your finished anchors will look like this.

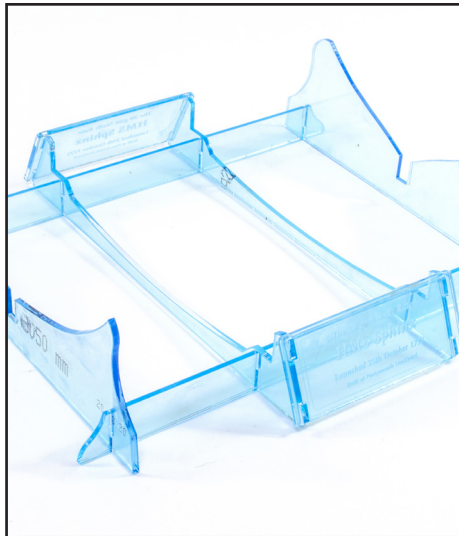

910. Finally, add the nameplates (488) themselves.



911. Your stand is now ready to accept your completed HMS Sphinx model. Thank you very much for building this release, and we hope you thoroughly enjoyed the project.







**The 20 Gun 6th Rate Sphinx– 1:64th scale
PARTS LIST**

Pt. No	Description	Quantity
4mm MDF		
1	Bulkhead	1
1-1	Bulkhead	1
1a	Bow Frame Pattern (Inner)	2
1b	Bow Frame Pattern (Middle)	2
1c	Bow Frame Pattern (Outer)	2
1d	Gun Deck Forward Support	2
2	Bulkhead	1
2-2	Bulkhead	1
2a	Gun Deck Support	2
3	Bulkhead	1
3a	Gun Deck Support	1
4	Bulkhead	1
4a	Gun Deck Support	1
5	Bulkhead	1
5a	Gun Deck Support	1
6	Bulkhead	1
6a	Gun Deck Support	2
7	Bulkhead	1
7a	Gun Deck Support	2
8	Bulkhead	1
8a	Gun Deck Support	2
9	Bulkhead	1
9a	Gun Deck Support	2
10	Bulkhead	1
10a	Gun Deck Support	1
11	Bulkhead	1
12	Bulkhead	1
13	Bulkhead	1
13-1	Bulkhead (Rear)	1
13a	Stern Transom Pattern	2
13b	Stern Transom Pattern	2
13c	Stern Transom Pattern	2
13d	Stern Transom Pattern	2

13e	Stern Transom Pattern	2
13f	Stern Transom Pattern	2
14	Gun Deck Longitudinal Beam (Inner)	2
15	Gun Deck Longitudinal Beam (Outer)	2
16	Forecastle Bulwark Pattern	2
17	Forecastle Bulwark Pattern	1
18	Bow Curve Pattern	2
J-4	Width Jig Beam for Bulkhead 4	1
J-5	Width Jig Beam for Bulkhead 5	1
J-6	Width Jig Beam for Bulkhead 6	1
J-7	Width Jig Beam for Bulkhead 7	1
3mm MDF		
0	Keel Pattern	1
1e	Gun Deck Support pattern	2
19	Bow Planking Pattern	2
20	Bow Planking Pattern	2
21	Bow Planking Pattern	2
22	Stern Planking Pattern	2
23	Stern Planking Pattern	2
24	Stern Planking Pattern	2
25	Stern Transom/Counter Frame (Inner)	2
26	Stern Transom/Counter Frame (Middle)	2
27	Stern Transom/Counter Frame (Outer)	2
28	Stern Transom/Counter Frame Filler	2
29	Quarter Gallery Lower Finishing Pattern	2
30	Forecastle Deck Jig (DO NOT GLUE)	2
31	Building Cradle (Fore)	1
32	Building Cradle (Aft)	1
33	Building Cradle Cross Beam	2
34	Building Cradle Cross Beam Securing Peg	4
35	Longitudinal Gun Port Frame Pattern (Lower)	2
36	Longitudinal Gun Port Frame Pattern (Upper)	2
37	Forecastle Bulwark Pattern	2
38	Bower Anchor	4
J-U	Forecastle Deck Jig Cross Beam	1
J-V	Forecastle Deck Jig Cross Beam	1
J-X	Forecastle Deck Jig Cross Beam	1
J-Y	Forecastle Deck Jig Cross Beam	1
J-Z	Forecastle Deck Jig Cross Beam	1

2mm Plywood

39	Orlop Section	2mm Ply	1
40	Lower Deck	2mm Ply	1
41	Stern frame Spacer Beam	2mm Ply	1
42	Bow 'V' Frame	2mm Ply	1
43	Bow 'V' Frame	2mm Ply	1
44	Bow 'V' Frame	2mm Ply	1

2mm MDF

45	Quarter Gallery pattern	2mm MDF	4
45a	Quarter Gallery pattern	2mm MDF	2
45b	Quarter Gallery pattern	2mm MDF	2
45c	Quarter Gallery pattern	2mm MDF	2
46	Quarter Gallery Lower Finishing pattern	2mm MDF	2
GP1	Gun Port Vertical Frame	2mm MDF	4
GP2	Gun Port Vertical Frame	2mm MDF	4
GP3	Gun Port Vertical Frame	2mm MDF	4
GP4	Gun Port Vertical Frame	2mm MDF	4
GP5	Gun Port Vertical Frame	2mm MDF	4
GP6	Gun Port Vertical Frame	2mm MDF	4
GP7	Gun Port Vertical Frame	2mm MDF	4
GP8	Gun Port Vertical Frame	2mm MDF	4
GP9	Gun Port Vertical Frame	2mm MDF	4
GP10	Gun Port Vertical Frame	2mm MDF	4
GP11	Gun Port Vertical Frame	2mm MDF	4
J-9	Width Retention Bar for Bulkhead 9	2mm MDF	1
J-10	Width Retention Bar for Bulkhead 10	2mm MDF	1
J-11	Width Retention Bar for Bulkhead 11	2mm MDF	1
J-12	Width Retention Bar for Bulkhead 12	2mm MDF	1
P0	28 Foot Pinnacle Bulkhead Spacing Board	2mm MDF	1
P1	28 Foot Pinnacle Bulkhead	2mm MDF	1
P2	28 Foot Pinnacle Bulkhead	2mm MDF	1
P3	28 Foot Pinnacle Bulkhead	2mm MDF	1
P4	28 Foot Pinnacle Bulkhead	2mm MDF	1
P5	28 Foot Pinnacle Bulkhead	2mm MDF	1
P6	28 Foot Pinnacle Bulkhead	2mm MDF	1
P7	28 Foot Pinnacle Bulkhead	2mm MDF	1
P8	28 Foot Pinnacle Bulkhead	2mm MDF	1

P9	28 Foot Pinnacle Bulkhead	2mm MDF	1
P10	28 Foot Pinnacle Bulkhead	2mm MDF	1
P11	28 Foot Pinnacle Bulkhead	2mm MDF	1
Y0	22 Foot Yawl Bulkhead Spacing Board	2mm MDF	1
Y1	22 Foot Yawl Bulkhead	2mm MDF	1
Y2	22 Foot Yawl Bulkhead	2mm MDF	1
Y3	22 Foot Yawl Bulkhead	2mm MDF	1
Y4	22 Foot Yawl Bulkhead	2mm MDF	1
Y5	22 Foot Yawl Bulkhead	2mm MDF	1
Y6	22 Foot Yawl Bulkhead	2mm MDF	1
Y7	22 Foot Yawl Bulkhead	2mm MDF	1
Y8	22 Foot Yawl Bulkhead	2mm MDF	1
Y9	22 Foot Yawl Bulkhead	2mm MDF	1
L0	24 Foot Launch Bulkhead Spacing Board	2mm MDF	1
L1	24 Foot Launch Bulkhead	2mm MDF	1
L2	24 Foot Launch Bulkhead	2mm MDF	1
L3	24 Foot Launch Bulkhead	2mm MDF	1
L4	24 Foot Launch Bulkhead	2mm MDF	1
L5	24 Foot Launch Bulkhead	2mm MDF	1
L6	24 Foot Launch Bulkhead	2mm MDF	1
L7	24 Foot Launch Bulkhead	2mm MDF	1
L8	24 Foot Launch Bulkhead	2mm MDF	1
L9	24 Foot Launch Bulkhead	2mm MDF	1
L10	24 Foot Launch Bulkhead	2mm MDF	1
L11	24 Foot Launch Bulkhead	2mm MDF	1
L12	24 Foot Launch Bulkhead	2mm MDF	1

0.8mm Plywood

47	Gun Deck Pattern (Left)	0.8mm Ply	1
48	Gun Deck Pattern (Right)	0.8mm Ply	1
49	Quarterdeck Pattern (Optional)	0.8mm Ply	1
50	Forecastle Deck Pattern (Optional)	0.8mm Ply	1
51	Quarter Gallery Spacer	0.8mm Ply	2
52	Anchor Fluke	0.8mm Ply	8
136	Upper Hull Side Pattern (Left)	0.8mm Ply	1
138	Upper Hull Side Pattern (Right)	0.8mm Ply	1
J-0	Quarterdeck Bulkheads Retention Key	0.8mm Ply	14

0.8mm Laser Engraved Veneer

53	Gun Deck Pattern	0.8 Veneer	1
54	Aft Gun Deck Chequer Pattern	0.8 Veneer	1
55	Quarterdeck Pattern	0.8 Veneer	1
56	Forecastle Deck Pattern	0.8 Veneer	1
57	Gangway Deck Pattern (Right)	0.8 Veneer	1
58	Gangway Deck Pattern (Left)	0.8 Veneer	1

0.6mm Wood

59	Forward Gun Deck Cabin Bulkhead (Front)	0.6mm Wood	1
60	Forward Gun Deck Cabin Bulkhead (Rear)	0.6mm Wood	1
61	Gun Deck Screen Bulkhead (Left)	0.6mm Wood	1
62	Gun Deck Screen Bulkhead (Right)	0.6mm Wood	1
63	Aft Gun Deck Cabin Bulkhead (Front)	0.6mm Wood	1
64	Aft Gun Deck Cabin Bulkhead (Rear)	0.6mm Wood	1
65	Galley Door Panel (Front Right)	0.6mm Wood	1
66	Galley Door Panel (Front Left)	0.6mm Wood	1
67	Galley Door Panel (Rear Left)	0.6mm Wood	1
68	Galley Door Panel (Rear Right)	0.6mm Wood	1
69	Cabin Bulkhead Infill Pattern (Right)	0.6mm Wood	4
70	Cabin Bulkhead Infill Pattern (Left)	0.6mm Wood	4
71	Strake Above Main Wale (Front Right)	0.6mm Wood	1
72	Strake Above Main Wale (Rear Right)	0.6mm Wood	1
73	Strake Above Main Wale (Front Left)	0.6mm Wood	1
74	Strake Above Main Wale (Rear Left)	0.6mm Wood	1
75	Stern Upper Counter Pattern (Outer)	0.6mm Wood	1
76	Stern Lower Counter Pattern (Outer)	0.6mm Wood	1
77	Upper breast Rail	0.6mm Wood	1
78	Upper breast Rail Top Pattern	0.6mm Wood	1
79	'Ekeing' Moulding Pattern (Left)	0.6mm Wood	1
80	'Ekeing' Moulding Pattern (Right)	0.6mm Wood	1
81	'V' Shaped Head Rail Pattern	0.6mm Wood	2
82	'V' Shaped Head Rail Pattern	0.6mm Wood	2
83	'V' Shaped Head Rail Pattern	0.6mm Wood	2
84	Cathead Top Pattern	0.6mm Wood	2
85	Cathead Bottom Pattern	0.6mm Wood	2
86	Cathead End Moulding	0.6mm Wood	2

87	Oars for 28' Pinnacle and 22' Yawl	0.6mm Wood	16
88	Stern Fascia (Inner)	0.6mm Wood	1
89	Quarter gallery Window Pattern (Inner)	0.6mm Wood	2
90	Panelling for Part Number 467	0.6mm Wood	2
91	Quarterdeck Fife Rail Outer Pattern	0.6mm Wood	4
92	Fore Mast front Fish	0.6mm Wood	1
93	Main Mast front Fish	0.6mm Wood	1
94	Quarterdeck Inner Bulwark (Left)	0.6mm Wood	1
95	Quarterdeck Inner Bulwark (Right)	0.6mm Wood	1
96	Forecastle Inner Bulwark (Front)	0.6mm Wood	2
97	Forecastle Inner Bulwark (Rear)	0.6mm Wood	2
98	Quarterdeck Inner Main Drift Pattern	0.6mm Wood	2
99	Quarterdeck Gangway Step Top	0.6mm Wood	2
100	Waist Gangway Pattern	0.6mm Wood	2
101	Galley Door Frame (Outer)	0.6mm Wood	1
102	Main Yard Brace Sheave Outer Pattern	0.6mm Wood	4
103	Forecastle Fish Davit Chock Outer Pattern	0.6mm Wood	4
104	Belfry Canopy Mid Pattern	0.6mm Wood	2
105	Belfry Cleat	0.6mm Wood	2
106	Gun Deck Lower Spirketting (Front Left)	0.6mm Wood	1
107	Gun Deck Lower Spirketting (Rear Left)	0.6mm Wood	1
108	Gun Deck Lower Spirketting (Front Right)	0.6mm Wood	1
109	Gun Deck Lower Spirketting (Rear Right)	0.6mm Wood	1
110	'Deck Clamp' Pattern (Front)	0.6mm Wood	2
111	'Deck Clamp' Pattern (Rear)	0.6mm Wood	2
112	Hull Side Step (Top)	0.6mm Wood	20
113	Hull Side Step (Bottom)	0.6mm Wood	20
114	Anchor Stock Side Pattern	0.6mm Wood	4
115	Anchor Stock Side Pattern	0.6mm Wood	4
116	Quarterdeck Ladder Side (Inner)	0.6mm Wood	2
117	Quarterdeck Ladder Side (Outer Right)	0.6mm Wood	1
118	Quarterdeck Ladder Side (Outer Left)	0.6mm Wood	1
119	Quarterdeck Ladder Step	0.6mm Wood	8
120	Mid Gun deck Ladder Side (Inner)	0.6mm Wood	2
121	Mid Gun deck Ladder Side (Outer Left)	0.6mm Wood	2
122	Mid Gun deck Ladder Side (Outer Right)	0.6mm Wood	2
123	Mid Gun deck Ladder Step	0.6mm Wood	7
124	Gangway Ladder Side (Inner)	0.6mm Wood	4
125	Gangway Ladder Side (Outer Left)	0.6mm Wood	2
126	Gangway Ladder Side (Outer Right)	0.6mm Wood	2

127	Gangway Ladder Step	0.6mm Wood	10
128	Aft Gun Deck Ladder Side	0.6mm Wood	2
129	Aft Gun Deck Ladder Side (Outer Left)	0.6mm Wood	1
130	Aft Gun Deck Ladder Side (Outer Right)	0.6mm Wood	1
131	Aft Gun Deck Ladder Step	0.6mm Wood	8
132	Fore Mast Batten	0.6mm Wood	8
133	Main Mast Batten	0.6mm Wood	8
134	Mizzen Mast Batten	0.6mm Wood	8
135	Seat of Ease Top	0.6mm Wood	2

1mm Wood

137	Main Wale Pattern (Left)	1mm Wood	1
139	Main Wale Pattern (Right)	1mm Wood	1
140	Sheer Rail Pattern (Rear Right)	1mm Wood	1
141	Waist Rail Pattern (Rear Right)	1mm Wood	1
142	Sheer and Waist Rail Pattern (Mid-Right)	1mm Wood	1
143	Sheer and Waist Rail Pattern (Front-Right)	1mm Wood	1
144	Sheer Rail Pattern (Rear Left)	1mm Wood	1
145	Waist Rail Pattern (Rear Left)	1mm Wood	1
146	Sheer and Waist Rail Pattern (Mid-left)	1mm Wood	1
147	Sheer and Waist Rail Pattern (Front-left)	1mm Wood	1
148	Side Fender Pattern	1mm Wood	4
149	Forecastle Gunwale Pattern	1mm Wood	2
151	Quarterdeck Breast Beam Lower Pattern	1mm Wood	1
152	Quarterdeck Breast Beam Middle Pattern	1mm Wood	1
153	Quarterdeck Waist Rail Pattern	1mm Wood	2
154	Quarterdeck Waist Rail Upper Pattern	1mm Wood	2
155	Lower Counter Pattern (Inner)	1mm Wood	1
156	Upper Counter Pattern (Inner)	1mm Wood	1
157	Stern Fascia Pattern (Outer)	1mm Wood	1
158	Quarter Gallery Window Pattern (Outer)	1mm Wood	2
159	Quarter Gallery 'Berthing' Pattern	1mm Wood	2
160	Bow Grating Pattern (Inner)	1mm Wood	1
161	Bow Grating Pattern (Outer)	1mm Wood	1
162	Binnacle Pattern (Towards Wheel)	1mm Wood	1
163	Binnacle Pattern	1mm Wood	1
164	Binnacle Side Pattern	1mm Wood	2
165	Binnacle Inner Pattern (Bottom)	1mm Wood	1
166	Binnacle Inner Pattern (Middle)	1mm Wood	1

167	Binnacle Inner Pattern (Top)	1mm Wood	1
168	Binnacle Canopy	1mm Wood	1
169	Small Cleat for Inner Stern Fascia	1mm Wood	8
170	Quarterdeck Gunwale	1mm Wood	2
171	Bow Hair Bracket (Left)	1mm Wood	1
172	Bow Lower Rail (Left)	1mm Wood	1
173	Bow Hair Bracket (Right)	1mm Wood	1
174	Bow Lower Rail (Right)	1mm Wood	1
175	Main Rail Upper Finishing Pattern (Right)	1mm Wood	1
176	Main Rail Upper Finishing Pattern (Left)	1mm Wood	1
177	Belfry Outer Canopy Pattern	1mm Wood	2
178	Belfry Lower Support Pattern	1mm Wood	2
179	Forecastle Breast Beam Rail	1mm Wood	2
180	Galley Door Frame Inner Pattern	1mm Wood	1
181	Forecastle Hatch Coaming Pattern	1mm Wood	1
182	Forecastle Hatch Grating Pattern (Fore)	1mm Wood	1
183	Forecastle Hatch Grating Pattern (Aft)	1mm Wood	1
184	Quarterdeck Hatch Coaming Pattern	1mm Wood	1
185	Quarterdeck Ladder Hatch Coaming Pattern	1mm Wood	1
186	Quarterdeck Gratings Pattern	1mm Wood	1
187	Prow, Keel & Rudder Post Location Peg	1mm Wood	10
188	Rudder Post Outer Pattern (Right)	1mm Wood	1
189	Rudder Post Outer Pattern (Left)	1mm Wood	1
190	Prow Outer Pattern (Left)	1mm Wood	1
191	Prow Outer Pattern (Right)	1mm Wood	1
192	Keel Outer Pattern (Left)	1mm Wood	1
193	Keel Outer Pattern (Right)	1mm Wood	1
194	Rudder Outer Pattern (Left)	1mm Wood	1
195	Rudder Outer Pattern (Right)	1mm Wood	1
196	Rudder Post End Pattern	1mm Wood	1
197	Stern Cabin Bulkhead Pattern	1mm Wood	1
198	Stern Cabin Seat Pattern	1mm Wood	1
199	Chain Pump Outer Pattern	1mm Wood	4
200	Stove Brick Pattern Floor Pattern	1mm Wood	1
201	Ships Wheel Outer Drum	1mm Wood	2
202	Fore and Main Mast Base	1mm Wood	4
203	Mizzen Mast Base	1mm Wood	2
204	Stove Pattern	1mm Wood	1
205	Stove Pattern	1mm Wood	1

206	Stove Pattern	1mm Wood	1
207	Stove Pattern	1mm Wood	1
208	Stove Pattern	1mm Wood	1
209	Stove Pattern	1mm Wood	1
210	Stove Pattern	1mm Wood	1
211	Stove Pattern	1mm Wood	1
212	Stove Pattern	1mm Wood	1
213	Inner Gundeck Bulwark Pattern (Front Left)	1mm Wood	1
214	Inner Gundeck Bulwark Pattern (Rear Left)	1mm Wood	1
215	Inner Gundeck Bulwark Pattern (Front Right)	1mm Wood	1
216	Inner Gundeck Bulwark Pattern (Rear Right)	1mm Wood	1
217	Fore Top Platform	1mm Wood	1
218	Fore Top Gunwale & Ribs	1mm Wood	1
219	Fore Mast Cheek	1mm Wood	2
220	Fore Mast Bib (Left)	1mm Wood	1
221	Fore Mast Bib (Right)	1mm Wood	1
222	Fore Topmast Trestle Tree	1mm Wood	2
223	Fore Topmast Fid	1mm Wood	1
224	Fore Topgallant mast Fid	1mm Wood	1
225	Fore Topgallant mast Truck	1mm Wood	1
226	Fore Top Rail	1mm Wood	1
227	Main Top Platform	1mm Wood	1
228	Main Top Gunwale & Ribs	1mm Wood	1
229	Main Mast Cheek	1mm Wood	2
230	Main Mast Bib (Left)	1mm Wood	1
231	Main Mast Bib (Right)	1mm Wood	1
232	Main Topmast Trestle Tree	1mm Wood	2
233	Main Topmast Fid	1mm Wood	1
234	Main Topgallant Mast Fid	1mm Wood	1
235	Main Topgallant mast Truck	1mm Wood	1
236	Main Top Rail	1mm Wood	1
237	Mizzen Top Platform	1mm Wood	1
238	Mizzen Top Gunwale & Ribs	1mm Wood	1
239	Mizzen Mast Bib (Left)	1mm Wood	1
240	Mizzen Mast Bib (Right)	1mm Wood	1
241	Mizzen Topmast Trestle Tree	1mm Wood	2
242	Mizzen Topmast Fid	1mm Wood	1
243	Mizzen Topgallant mast Fid	1mm Wood	1
244	Mizzen & Flagstaff Mast Truck	1mm Wood	2
245	Mizzen Top Rail	1mm Wood	1

246	Mizzen Belaying Pin Ring	1mm Wood	1
247	Bowsprit Bee	1mm Wood	1
248	Bowsprit Fairlead	1mm Wood	1
249	Jibboom Saddle	1mm Wood	1
250	Capstan Chock	1mm Wood	4
251	Capstan Lower Drum Head	1mm Wood	2
252	Capstan Drum Head for Bars	1mm Wood	2
253	Capstan Upper Drum Head (Gun Deck)	1mm Wood	1
254	Capstan Top Drum Head (Gun Deck)	1mm Wood	1
255	Capstan Upper Drum Head (Quarterdeck)	1mm Wood	1
256	Upper Drum Head Centre (Quarterdeck)	1mm Wood	1
257	Capstan Pawl Head	1mm Wood	4
258	7mm Closed Heart Block Outer pattern	1mm Wood	8
259	7mm Closed Heart Block Middle pattern	1mm Wood	4
260	7mm Closed Heart Block Alignment Key	1mm Wood	2
261	5.8mm Open Heart Block Outer pattern	1mm Wood	8
262	5.8mm Open Heart Block Middle pattern	1mm Wood	4
263	5.8mm Open Heart Block Alignment Key	1mm Wood	2
264	5mm Open Heart Block Outer pattern	1mm Wood	8
265	5mm Open Heart Block Middle pattern	1mm Wood	4
266	5mm Open Heart Block Alignment Key	1mm Wood	2
267	6mm Closed Heart Block Outer pattern	1mm Wood	8
268	6mm Closed Heart Block Middle pattern	1mm Wood	4
269	6mm Closed Heart Block Alignment Key	1mm Wood	2
270	Standard Mast & Yard Cleat	1mm Wood	182
L13	24 Foot Launch Stern Bulkhead	1mm Wood	1
L14	24 Foot Launch Keel	1mm Wood	1
L15	24 Foot Launch Bow Pattern	1mm Wood	2
L16	24 Foot Launch Seat	1mm Wood	1
L17	24 Foot Launch Seat	1mm Wood	1
L18	24 Foot Launch Seat	1mm Wood	1
L19	24 Foot Launch Seat	1mm Wood	1
L20	24 Foot Launch Seat	1mm Wood	1
L21	24 Foot Launch Seat	1mm Wood	1
L22	24 Foot Launch Seat	1mm Wood	1
L23	24 Foot Launch Rudder	1mm Wood	1
L24	24 Foot Launch Transom Knee	1mm Wood	2
L25	24 Foot Launch Davit	1mm Wood	1
L26	24 Foot Launch Davit Support	1mm Wood	2
L27	24 Foot Launch Stern Sheet Bench	1mm Wood	1

L28	24 Foot Launch breast Hook	1mm Wood	1
P12	28 Foot Pinnacle Stern Bulkhead (Inner)	1mm Wood	1
P13	28 Foot Pinnacle Stern Bulkhead	1mm Wood	1
P14	28 Foot Pinnacle Keel	1mm Wood	1
P15	28 Foot Pinnacle Bow Pattern	1mm Wood	2
P16	28 Foot Pinnacle Bow decking	1mm Wood	1
P17	28 Foot Pinnacle Rudder	1mm Wood	1
P18	28 Foot Pinnacle Seat	1mm Wood	1
P19	28 Foot Pinnacle Seat	1mm Wood	1
P20	28 Foot Pinnacle Seat	1mm Wood	1
P21	28 Foot Pinnacle Seat	1mm Wood	1
P22	28 Foot Pinnacle Seat	1mm Wood	1
P23	28 Foot Pinnacle Seat	1mm Wood	1
P24	28 Foot Pinnacle Stern Sheet Bench	1mm Wood	1
P25	28 Foot Pinnacle Transom Knee	1mm Wood	2
Y10	22 Foot Yawl Stern Bulkhead (Inner)	1mm Wood	1
Y11	22 Foot Yawl Stern Bulkhead	1mm Wood	1
Y12	22 Foot Yawl Keel	1mm Wood	1
Y13	22 Foot Yawl Bow Pattern	1mm Wood	2
Y14	22 Foot Yawl Bow Pattern	1mm Wood	2
Y15	22 Foot Yawl Rudder	1mm Wood	1
Y16	22 Foot Yawl Bow Decking	1mm Wood	1
Y17	22 Foot Yawl Seat	1mm Wood	1
Y18	22 Foot Yawl Seat	1mm Wood	1
Y19	22 Foot Yawl Seat	1mm Wood	1
Y20	22 Foot Yawl Seat	1mm Wood	1
Y21	22 Foot Yawl Stern Sheet Bench	1mm Wood	1
Y22	22 Foot Yawl Stern Floor	1mm Wood	1

0.8mm Wood

271	Outer Planking Pattern (Right Aft)	0.8mm Wood	1
272	Outer Planking Pattern (Right Fore)	0.8mm Wood	1
273	Outer Planking Pattern (left Aft)	0.8mm Wood	1
274	Outer Planking Pattern (Left Fore)	0.8mm Wood	1
275	Quarterdeck Beam Moulding	0.8mm Wood	1
276	Forecastle Deck Beam Moulding	0.8mm Wood	1
277	Quarter Gallery Upper Fretwork (Left)	0.8mm Wood	1
278	Quarter Gallery Upper Fretwork (Right)	0.8mm Wood	1
279	Stern Wing Transom Rail (Left)	0.8mm Wood	1

280	Stern Wing Transom Rail (Right)	0.8mm Wood	1
281	Stern Lower Counter Rail	0.8mm Wood	1
282	Stern Upper Counter Rail	0.8mm Wood	1
283	Stern Upper Rail Filling Pattern (Right)	0.8mm Wood	1
284	Stern Upper Rail Filling Pattern (Left)	0.8mm Wood	1
285	Quarter Gallery Upper Rail (Left)	0.8mm Wood	1
286	Quarter Gallery Middle Rail (Left)	0.8mm Wood	1
287	Quarter Gallery Lower Rail (Left)	0.8mm Wood	1
288	Quarter Gallery Upper Rail (Right)	0.8mm Wood	1
289	Quarter Gallery Middle Rail (Right)	0.8mm Wood	1
290	Quarter Gallery Lower Rail (Right)	0.8mm Wood	1
291	Bow Lower Rail (Left)	0.8mm Wood	1
292	Bow Lower Rail (Right)	0.8mm Wood	1
293	Gun Port Lid Inner	0.8mm Wood	2
294	Gun Port Lid Outer Right	0.8mm Wood	1
295	Gun Port Lid Inner	0.8mm Wood	2
296	Gun Port Lid Outer Right	0.8mm Wood	1
297	Gun Port Lid Inner	0.8mm Wood	2
298	Gun Port Lid Outer Right	0.8mm Wood	1
299	Gun Port Lid Outer Left	0.8mm Wood	1
300	Gun Port Lid Outer Left	0.8mm Wood	1
301	Gun Port Lid Outer Left	0.8mm Wood	1
302	Bow Main Rail (Outer Right)	0.8mm Wood	1
303	Bow Main Rail (Outer Left)	0.8mm Wood	1
304	Bow Main Rail (Inner)	0.8mm Wood	2
305	Outer Planking Pattern (Lower Front Right)	0.8mm Wood	1
306	Outer Planking Pattern (Lower Rear Right)	0.8mm Wood	1
307	Outer Planking Pattern (Lower Front Left)	0.8mm Wood	1
308	Outer Planking Pattern (Lower Rear Left)	0.8mm Wood	1
309	Plank Pattern (Front Upper)	0.8mm Wood	2
310	Plank Pattern (Rear Upper)	0.8mm Wood	2
311	Plank Pattern (Front Lower)	0.8mm Wood	2
312	Plank Pattern (Rear Lower)	0.8mm Wood	2

1.5mm Wood

150	Waist Gunwale Pattern	1.5mm Wood	2
313	Lower Deck Forward Coaming (Lower)	1.5mm Wood	1
314	Lower Deck Forward Coaming (Upper)	1.5mm Wood	1

315	Lower Deck Forward Grating	1.5mm Wood	1	355	Gun Deck Foreword Hatch Coaming (Lower)	1.5mm Wood	1
316	Lower Deck Main Hatch Coaming (Lower)	1.5mm Wood	1	356	Gun Deck Foreword Hatch Coaming (Upper)	1.5mm Wood	1
317	Lower Deck Main Hatch Coaming (Upper)	1.5mm Wood	1	357	Gun Deck Foreword Hatch Grating	1.5mm Wood	1
318	Lower Deck Main Hatch Grating	1.5mm Wood	1	358	Gun Deck Main Hatch Coaming (Lower)	1.5mm Wood	1
319	Lower Deck Aft Hatch Coaming (Lower)	1.5mm Wood	1	359	Gun Deck Main Hatch Coaming (Upper)	1.5mm Wood	1
320	Lower Deck Aft Hatch Coaming (Upper)	1.5mm Wood	1	360	Gun Deck Main Hatch Grating	1.5mm Wood	1
321	Lower Deck Aft Hatch Grating	1.5mm Wood	1	361	Gun Deck Aft Hatch Coaming (Lower)	1.5mm Wood	1
322	Lower Deck Aftermost Hatch Coaming (Lower)	1.5mm Wood	1	362	Gun Deck Aft Hatch Coaming (Upper)	1.5mm Wood	1
323	Lower Deck Aftermost Hatch Coaming (Upper)	1.5mm Wood	1	363	Gun Deck Aft Hatch Grating	1.5mm Wood	1
324	Lower Deck Aftermost Hatch Grating	1.5mm Wood	1	364	Gun Deck Aft Ladder Coaming (Lower)	1.5mm Wood	1
325	Quarterdeck Rail Stanchion (Foremost)	1.5mm Wood	2	365	Gun Deck Aft Ladder Coaming (Upper)	1.5mm Wood	1
326	Quarterdeck Timberhead	1.5mm Wood	2	366	9-Pounder Carriage Side (Left)	1.5mm Wood	20
327	Quarterdeck Timberhead	1.5mm Wood	2	367	9-Pounder Carriage Side (Right)	1.5mm Wood	20
328	Quarterdeck Rail Stanchion	1.5mm Wood	2	368	9-Pounder Carriage Front Axle	1.5mm Wood	20
329	Quarterdeck Timberhead	1.5mm Wood	2	369	9-Pounder Carriage Rear Axle	1.5mm Wood	20
330	Quarterdeck Timberhead	1.5mm Wood	2	370	9-Pounder Carriage Front Wheel	1.5mm Wood	40
331	Quarterdeck Rail Stanchion	1.5mm Wood	2	371	9-Pounder Carriage Rear Wheel	1.5mm Wood	40
332	Quarterdeck Timberhead	1.5mm Wood	2	372	9-Pounder Carriage Quoin	1.5mm Wood	20
333	Quarterdeck Timberhead	1.5mm Wood	2	373	Fore Channel	1.5mm Wood	2
334	Quarterdeck Rail Stanchion	1.5mm Wood	2	374	Main Channel	1.5mm Wood	2
335	Quarterdeck Timberhead	1.5mm Wood	2	375	Mizzen Channel	1.5mm Wood	2
336	Quarterdeck Timberhead	1.5mm Wood	2	376	Fore & Main 'Stool'	1.5mm Wood	4
337	Quarterdeck Rail Stanchion	1.5mm Wood	2	377	Fore Channel Knee (Front)	1.5mm Wood	4
338	Quarterdeck Rail Stanchion	1.5mm Wood	2	378	Fore Channel Knee (Middle)	1.5mm Wood	4
339	Quarterdeck Rail Stanchion (Aftermost)	1.5mm Wood	2	379	Fore Channel Knee (Rear)	1.5mm Wood	6
340	Ships Wheel Standard (Front)	1.5mm Wood	1	380	Main Channel Knee (Front)	1.5mm Wood	6
341	Ships Wheel Standard (Rear)	1.5mm Wood	1	381	Main Channel Knee (Rear)	1.5mm Wood	8
342	Forecastle Timberhead	1.5mm Wood	2	382	Mizzen Channel Knee	1.5mm Wood	8
343	Forecastle Timberhead	1.5mm Wood	2	383	Chess Tree Pattern	1.5mm Wood	2
344	Forecastle Timberhead	1.5mm Wood	2	384	Hawse Bolster	1.5mm Wood	2
345	Forecastle Timberhead & Fish Davit Crutch	1.5mm Wood	2	385	Mizzen Cross Tree	1.5mm Wood	2
346	Forecastle Timberhead	1.5mm Wood	2	385a	Mizzen Shroud Bolster	1.5mm Wood	2
347	Forecastle Timberhead	1.5mm Wood	2	386	Gangway Support Knee (Foremost)	1.5mm Wood	2
348	Forecastle Timberhead	1.5mm Wood	2	387	Gangway Support Knee (Bulkhead 4)	1.5mm Wood	2
349	Forecastle Timberhead	1.5mm Wood	2	388	Gangway Support Knee (Bulkhead 5)	1.5mm Wood	2
350	Forecastle Timberhead	1.5mm Wood	2	389	Gangway Support Knee (Bulkhead 6)	1.5mm Wood	2
351	Shroud Cleat	1.5mm Wood	52	390	Gangway Support Knee (Bulkhead 7)	1.5mm Wood	4
352	Forecastle Breast Beam Support Knee	1.5mm Wood	6	391	Gangway Support Knee (Near Quarterdeck)	1.5mm Wood	4
353	Belfry Support Knee	1.5mm Wood	2	392	Quarterdeck Beam Hanging Knee (Optional)	1.5mm Wood	32
354	Quarterdeck Fife Rail Main Pattern	1.5mm Wood	2	393	Bowsprit Gammoning Cleat	1.5mm Wood	8

394	Topsail Yard Tie Cleat	1.5mm Wood	12
395	Topgallant Yard Tie Cleat	1.5mm Wood	12
396	Lower yard Outer Cleat	1.5mm Wood	15
397	General Mast/Yard Cleat	1.5mm Wood	30
398	Deck & Quarterdeck Bulwark Cleat	1.5mm Wood	16
399	Quarterdeck Inner Bulwark (Front)	1.5mm Wood	2
400	Quarterdeck Inner Bulwark (Rear)	1.5mm Wood	2
401	Forecastle Inner Bulwark (Front)	1.5mm Wood	2
402	Forecastle Inner Bulwark (Rear)	1.5mm Wood	2
403	Stern Ensign Staff Upper Bracket	1.5mm Wood	1
404	Stern Ensign Staff Lower Bracket	1.5mm Wood	1
405	Quarterdeck Front Drift Rail Pattern	1.5mm Wood	2
406	Transom Knee	1.5mm Wood	2
407	Quarterdeck Breast Rail Stanchion (Gangway)	1.5mm Wood	2
408	Quarterdeck Front Timberhead	1.5mm Wood	4

2mmWood

211a	Spacer Pattern for Ships Stove	2mm Wood	1
409	Quarterdeck Beam Spacing Pattern (Right)	2mm Wood	1
410	Quarterdeck Beam Spacing Pattern (Left)	2mm Wood	1
411	Forecastle Longitudinal Deck Beam	2mm Wood	2
412	Chain Pump Handle Stanchion (Fore)	2mm Wood	2
413	Chain Pump Handle Stanchion (Aft)	2mm Wood	2
414	Quarterdeck Carling Beam (Mizzen Mast)	2mm Wood	2
414a	Quarterdeck Carling Beam (Coaming)	2mm Wood	4
415	Forecastle Carling Beam	2mm Wood	6
416	Mizzen Cross Tree	2mm Wood	2
417	Mizzen Cross Tree Chock	2mm Wood	1
418	Fore & Main Shroud Bolster	2mm Wood	4
419	Fore & Main Cross Tree Chock	2mm Wood	2
420	Main Trestle Tree	2mm Wood	2
421	Fore Trestle Tree	2mm Wood	2
422	Mizzen Topmast Cap	2mm Wood	1
423	Mizzen Gaff Jaws	2mm Wood	1
424	Lower Yard Tie Cleat	2mm Wood	16
425	Forecastle Carling Beam	2mm Wood	2
426	Fore Bitts Cross Beam	2mm Wood	2
427	Forecastle Rail Stanchion	2mm Wood	6
428	Knight's head	2mm Wood	2

429	Belfry Main Pattern	2mm Wood	1
430	Gun Deck Bulwark Cleat	2mm Wood	4
431	Main Bitts Cross Beam	2mm Wood	2
432	Bow Cheek	2mm Wood	4
433	Cathead Side	2mm Wood	2
434	Cathead Side	2mm Wood	2
435	Cathead Knee	2mm Wood	2
436a	Quarterdeck Breast Rail Stanchion (Far Left)	2mm Wood	1
436b	Quarterdeck Breast Rail Stanchion	2mm Wood	1
436c	Quarterdeck Breast Rail Stanchion	2mm Wood	1
436d	Quarterdeck Breast Rail Stanchion	2mm Wood	1
436e	Quarterdeck Breast Rail Stanchion	2mm Wood	1
436f	Quarterdeck Breast Rail Stanchion (Far Right)	2mm Wood	1
437	Capstan Whelp	2mm Wood	12
438	Quarterdeck Gangway Step	2mm Wood	2
439	22 Foot Yawl Front Cradle	2mm Wood	1
440	22 Foot Yawl Rear Cradle	2mm Wood	1
441	24 Foot Launch Front Cradle	2mm Wood	1
442	24 Foot Launch Rear Cradle	2mm Wood	1
443	28 Foot Pinnacle Front Cradle	2mm Wood	1
444	28 Foot Pinnacle Rear Cradle	2mm Wood	1
483	Anchor Stock	2mm Wood	8

3mmWood

445	Prow Pattern	3mm Wood	1
446	Keel Pattern	3mm Wood	1
447	Rudder Post Pattern	3mm Wood	1
448	Rudder Pattern	3mm Wood	1
449	'Gammoning Knee'	3mm Wood	1
450	Wash Cant (Requires Shaping)	3mm Wood	2
451	Ships Wheel Drum Centre	3mm Wood	2
452	Seat of Ease Pattern	3mm Wood	2
453	Main Cross Tree	3mm Wood	2
454	Fore Cross Tree	3mm Wood	2
455	Forecastle Gunwale Snatch Block	3mm Wood	2
456	Quarterdeck Beam Carling	3mm Wood	2
457	Quarterdeck Beam Carling	3mm Wood	2
458A	Quarterdeck Beam (Front)	3mm Wood	1
458B	Quarterdeck Beam	3mm Wood	1

458C	Quarterdeck Beam	3mm Wood	1
458D	Quarterdeck Beam	3mm Wood	1
458E	Quarterdeck Beam	3mm Wood	2
458F	Quarterdeck Beam	3mm Wood	1
458G	Quarterdeck Beam	3mm Wood	1
458H	Quarterdeck Beam	3mm Wood	1
458I	Quarterdeck Beam	3mm Wood	1
458J	Quarterdeck Beam	3mm Wood	1
458K	Quarterdeck Beam	3mm Wood	1
458L	Quarterdeck Beam	3mm Wood	1
458M	Quarterdeck Beam	3mm Wood	1
458N	Quarterdeck Beam	3mm Wood	1
458O	Quarterdeck Beam	3mm Wood	1
458P	Quarterdeck Beam	3mm Wood	1
458Q	Quarterdeck Beam	3mm Wood	1
458R	Quarterdeck Beam (Aft)	3mm Wood	1
459	Forecastle Beam Carling	3mm Wood	2
460RF	Forecastle Deck Beam (Front)	3mm Wood	1
460S	Forecastle Deck Beam	3mm Wood	1
460T	Forecastle Deck Beam	3mm Wood	1
460U	Forecastle Deck Beam	3mm Wood	1
460V	Forecastle Deck Beam	3mm Wood	1
460W	Forecastle Deck Beam	3mm Wood	1
460X	Forecastle Deck Beam	3mm Wood	1
460Y	Forecastle Deck Beam	3mm Wood	1
460Z	Forecastle Deck Beam (Aft)	3mm Wood	1
461	Bowsprit Support (Fore Sheet Bitt Pin)	3mm Wood	1
462	Riding Bitts Cross Beam	3mm Wood	1
463	Fore Jeer Bitts	3mm Wood	1
464	Riding Bitts Knee	3mm Wood	2
465	Main Jeer Bitt Post - Left	3mm Wood	1
466	Main Jeer Bitt Post - Right	3mm Wood	1
467	Main Topsail Sheet Bitts and Gallows	3mm Wood	1
468	Fore Topsail Sheet Bitts	3mm Wood	2
469	Boat Cross Beam	3mm Wood	2
469a	Boat Cross Beam (Boat Cradle Markings)	3mm Wood	2
470	Mizzen Mast Cap	3mm Wood	1
471	Main Top Mast Cap	3mm Wood	1
472	Fore Top Mast Cap	3mm Wood	1

4mmWood

473	Main Mast Cap	4mm Wood	1
474	Bowsprit Cap	4mm Wood	1
475	Fore Mast Cap	4mm Wood	1
476	Chain Pump Main Pattern	4mm Wood	2
477	Aft Riding Bitts Post	4mm Wood	2
478	Fore Riding Bitts Post	4mm Wood	2
479	Fore Riding Bitts Post Support (Left)	4mm Wood	1
480	Fore Riding Bitts Post Support (Right)	4mm Wood	1
481	Quarter Gallery Upper Pattern (Right)	4mm Wood	1
482	Quarter Gallery Upper Pattern (Left)	4mm Wood	2

2mm Clear Acetate

484	Display Stand Front Cradle	2mm Acetate	1
485	Display Stand Aft Cradle	2mm Acetate	1
486	Display Stand Nameplate Cross Support	2mm Acetate	2
487	Display Stand Cross Support	2mm Acetate	2
488	Display Stand Nameplate	2mm Acetate	2

0.5mm Clear PETG Plastic

489	Stern Window Glazing	0.5mm Clear PETG	2
490	Stern Window Glazing	0.5mm Clear PETG	2
491	Stern Window Glazing	0.5mm Clear PETG	1
492	Quarter Gallery Window Glazing	0.5mm Clear PETG	2
493	Quarter Gallery Window Glazing	0.5mm Clear PETG	2
494	Quarter Gallery Window Glazing	0.5mm Clear PETG	2
495	Aft Cabin Bulkheads Window Glazing	0.5mm Clear PETG	8

0.2mm Photo-Etched Brass

PE-1R	Upper Frieze Work Pattern (Right)	0.2mm PE	1
PE-1L	Upper Frieze Work Pattern (Left)	0.2mm PE	1
PE-2R	Upper Frieze Work Pattern (Right)	0.2mm PE	1
PE-2L	Upper Frieze Work Pattern (Left)	0.2mm PE	1
PE-3R	Upper Frieze Work Pattern (Right)	0.2mm PE	1
PE-3L	Upper Frieze Work Pattern (Left)	0.2mm PE	1
PE-4R	Upper Frieze Work Pattern (Right)	0.2mm PE	1
PE-4L	Upper Frieze Work Pattern (Left)	0.2mm PE	1
PE-5Ra	Upper Frieze Work Pattern (Right)	0.2mm PE	1
PE-5Rb	Upper Frieze Work Pattern (Right)	0.2mm PE	1
PE-5Rc	Upper Frieze Work Pattern (Right)	0.2mm PE	1
PE-5Rd	Upper Frieze Work Pattern (Right)	0.2mm PE	1
PE-5Re	Upper Frieze Work Pattern (Right)	0.2mm PE	1
PE-5Rf	Upper Frieze Work Pattern (Right)	0.2mm PE	1
PE-5La	Upper Frieze Work Pattern (Left)	0.2mm PE	1
PE-5Lb	Upper Frieze Work Pattern (Left)	0.2mm PE	1
PE-5Lc	Upper Frieze Work Pattern (Left)	0.2mm PE	1
PE-5Ld	Upper Frieze Work Pattern (Left)	0.2mm PE	1
PE-5Le	Upper Frieze Work Pattern (Left)	0.2mm PE	1
PE-5Lf	Upper Frieze Work Pattern (Left)	0.2mm PE	1
PE-6R	Upper Frieze Work Pattern (Right)	0.2mm PE	1
PE-6L	Upper Frieze Work Pattern (Left)	0.2mm PE	1
PE-7R	Lower Frieze Work Pattern (Right)	0.2mm PE	1
PE-7L	Lower Frieze Work Pattern (Left)	0.2mm PE	1
PE-8R	Lower Frieze Work Pattern (Right)	0.2mm PE	1
PE-8L	Lower Frieze Work Pattern (Left)	0.2mm PE	1
PE-9R	Lower Frieze Work Pattern (Right)	0.2mm PE	1
PE-9L	Lower Frieze Work Pattern (Left)	0.2mm PE	1
PE-10R	Lower Frieze Work Pattern (Right)	0.2mm PE	1
PE-10L	Lower Frieze Work Pattern (Left)	0.2mm PE	1
PE-11R	Lower Frieze Work Pattern (Right)	0.2mm PE	1
PE-11L	Lower Frieze Work Pattern (Left)	0.2mm PE	1
PE-12R	Lower Frieze Work Pattern (Right)	0.2mm PE	1
PE-12L	Lower Frieze Work Pattern (Left)	0.2mm PE	1
PE-13R	Lower Frieze Work Pattern (Right)	0.2mm PE	1
PE-13L	Lower Frieze Work Pattern (Left)	0.2mm PE	1
PE-14R	Lower Frieze Work Pattern (Right)	0.2mm PE	1
PE-14L	Lower Frieze Work Pattern (Left)	0.2mm PE	1

PE-15R	Lower Frieze Work Pattern (Right)	0.2mm PE	1
PE-15L	Lower Frieze Work Pattern (Left)	0.2mm PE	1
PE-16R	Lower Frieze Work Pattern (Right)	0.2mm PE	1
PE-16L	Lower Frieze Work Pattern (Left)	0.2mm PE	1
PE-17R	Lower Frieze Work Pattern (Right)	0.2mm PE	1
PE-17L	Lower Frieze Work Pattern (Left)	0.2mm PE	1
PE-18R	Lower Frieze Work Pattern (Right)	0.2mm PE	1
PE-18L	Lower Frieze Work Pattern (Left)	0.2mm PE	1
PE-19R	Lower Frieze Work Pattern (Right)	0.2mm PE	1
PE-19L	Lower Frieze Work Pattern (Left)	0.2mm PE	1
PE-20R	Lower Frieze Work Pattern (Right)	0.2mm PE	1
PE-20L	Lower Frieze Work Pattern (Left)	0.2mm PE	1
PE-21La	Upper Finishing Tile Roof (Left)	0.2mm PE	2
PE-21Lb	Upper Finishing Tile Roof (Left)	0.2mm PE	1
PE-21Ra	Upper Finishing Tile Roof (Right)	0.2mm PE	2
PE-21Rb	Upper Finishing Tile Roof (Right)	0.2mm PE	1
PE-22R	Upper Finishing Tile Roof (Right)	0.2mm PE	1
PE-22L	Upper Finishing Tile Roof (Left)	0.2mm PE	1
PE-23R	Lower Quarter Gallery Decoration (Right)	0.2mm PE	1
PE-23L	Lower Quarter Gallery Decoration (Left)	0.2mm PE	1
PE23AL	Lower Quarter Gallery Decoration (Left)	0.2mm PE	1
PE23AR	Lower Quarter Gallery Decoration (Right)	0.2mm PE	1
PE-24R	Lower Quarter Gallery Drop Decoration (Right)	0.2mm PE	1
PE-24L	Lower Quarter Gallery Drop Decoration (Left)	0.2mm PE	1
PE-25R	Upper Stern Counter Decoration (Right)	0.2mm PE	1
PE-25L	Upper Stern Counter Decoration (Left)	0.2mm PE	1
PE-26	SPHINX Letters	0.2mm PE	6
PE-27	Prow Horseshoe Plate	0.2mm PE	2
PE-28	Stern Fishplate	0.2mm PE	2
PE-29	Depth Numerals	0.2mm PE	4
PE-30	Stern Lantern Frames	0.2mm PE	2
PE-31	Rudder Pintle Strap	0.2mm PE	2
PE-32	Rudder Pintle Strap	0.2mm PE	2
PE-33	Rudder Pintle Strap	0.2mm PE	2
PE-34	Rudder Pintle Strap	0.2mm PE	2
PE-35	Rudder Pintle Strap	0.2mm PE	2
PE-36	Rudder Brace Strap	0.2mm PE	2
PE-37	Rudder Brace Strap	0.2mm PE	2
PE-38	Rudder Brace Strap	0.2mm PE	2
PE-39	Rudder Brace Strap	0.2mm PE	2

PE-40	Rudder Brace Strap	0.2mm PE	2
PE-41	Chain Pump Strap/Capping	0.2mm PE	6
PE-42	Ships Wheel Inner Centre Plate	0.2mm PE	2
PE-43	Ships Wheel Outer Ring Plate	0.2mm PE	2
PE-44B	Screen Bulkhead Door Hinge	0.2mm PE	10
PE-44G	Galley Door Hinge	0.2mm PE	6
PE-45	Compass pattern for Binnacle	0.2mm PE	1
PE-46	9-Pounder Carriage Cap Square (NOT Required)	0.2mm PE	44
PE-47	Not in use		
PE-162	Galley Door Hinge	0.2mm PE	6

0.4mm Photo-Etched Brass – Sheet 1

PE-48	5mm Deadeye Strop	0.4mm PE	32
PE-49	Chainplate Upper Link (5mm Deadeye)	0.4mm PE	36
PE-50	Chainplate Middle Link (5mm Deadeye)	0.4mm PE	34
PE-51	Chainplate Fore Preventer Link (5mm Deadeye)	0.4mm PE	16
PE-52	Chainplate Main Preventer Link (5mm Deadeye)	0.4mm PE	20
PE-53	3mm Deadeye Strop	0.4mm PE	32
PE-54	Chainplate Upper Link (3mm Deadeye)	0.4mm PE	36
PE-55	Chainplate Upper Link (3mm Deadeye)	0.4mm PE	28
PE-56	3mm Futtock Strop	0.4mm PE	26
PE-57	3mm Futtock Strop Hook	0.4mm PE	28
PE-58	Parrel Rib	0.4mm PE	40
PE-59	Main Euphroe Block	0.4mm PE	1
PE-60	Fore Euphroe Block	0.4mm PE	1
PE-61	Mizzen Euphroe Block	0.4mm PE	1
PE-62	Main & Fore Yard Boom Iron Strap	0.4mm PE	4
PE-63	Main & Fore Topsail Yard Boom Iron Strap	0.4mm PE	4
PE-64	Mizzen Topmast Cross Tree Pattern	0.4mm PE	1
PE-65	Main Topmast Cross Tree Pattern	0.4mm PE	1
PE-66	Fore Topmast Cross Tree Pattern	0.4mm PE	1
PE-67	General Rigging Hook	0.4mm PE	64
PE-68	Fore & Main Channel Stunsail Boom Bracket	0.4mm PE	4
PE-69	Ships Stove End Pattern	0.4mm PE	1
PE-70	Ships Stove Right Side Pattern	0.4mm PE	1
PE-71	Ships Stove Left Side Pattern	0.4mm PE	1
PE-72	Ships Stove End Pattern	0.4mm PE	1
PE-73	Ships Stove Round Lid	0.4mm PE	1
PE-74	Ships Stove Oval Lid	0.4mm PE	1

PE-75	Ships Stove Side Door	0.4mm PE	2
PE-76	Ships Stove Handle	0.4mm PE	8
PE-77	Ships Stove Chain Pulley Inner Disc	0.4mm PE	2
PE-78	Ships Stove Chain Pulley Outer Disc	0.4mm PE	2
PE-79	Ships Stove Chain Pulley Pattern	0.4mm PE	1
PE-80	Ships Stove Flu Pattern	0.4mm PE	1
PE-81	0.8mm Hole Eyebolt (For Cannon)	0.4mm PE	320
PE-82	1.2mm Hole Eyebolt	0.4mm PE	74
PE-83	1.2mm Hole Eyebolt Ring	0.4mm PE	76

0.4mm Photo-Etched Brass – Sheet 2

PE-84	Forecastle Stanchion (Front)	0.4mm PE	2
PE-85	Forecastle Stanchion	0.4mm PE	2
PE-86	Forecastle Stanchion	0.4mm PE	2
PE-87	Forecastle Stanchion	0.4mm PE	2
PE-88	Forecastle Stanchion	0.4mm PE	2
PE-89	Forecastle Stanchion	0.4mm PE	2
PE-90	Forecastle Stanchion (Rear)	0.4mm PE	2
PE-91	Waist Hammock Crane	0.4mm PE	14
PE-92	Waist Stanchion	0.4mm PE	5
PE-93R	Quarterdeck Hammock Crane (Right)	0.4mm PE	2
PE-93L	Quarterdeck Hammock Crane (Left)	0.4mm PE	2
PE-94R	Quarterdeck Hammock Crane (Right)	0.4mm PE	2
PE-94L	Quarterdeck Hammock Crane (Left)	0.4mm PE	2
PE-95R	Quarterdeck Hammock Crane (Right)	0.4mm PE	2
PE-95L	Quarterdeck Hammock Crane (Left)	0.4mm PE	2
PE-96R	Quarterdeck Hammock Crane (Right)	0.4mm PE	2
PE-96L	Quarterdeck Hammock Crane (Left)	0.4mm PE	2
PE-97R	Quarterdeck Hammock Crane (Right)	0.4mm PE	2
PE-97L	Quarterdeck Hammock Crane (Left)	0.4mm PE	2
PE-98R	Quarterdeck Hammock Crane (Right)	0.4mm PE	2
PE-98L	Quarterdeck Hammock Crane (Left)	0.4mm PE	2
PE-99R	Quarterdeck Hammock Crane (Right)	0.4mm PE	2
PE-99L	Quarterdeck Hammock Crane (Left)	0.4mm PE	2
PE-100R	Quarterdeck Hammock Crane (Right)	0.4mm PE	2
PE-100L	Quarterdeck Hammock Crane (Left)	0.4mm PE	2
PE-101R	Quarterdeck Hammock Crane (Right)	0.4mm PE	2
PE-101L	Quarterdeck Hammock Crane (Left)	0.4mm PE	2
PE-102R	Quarterdeck Hammock Crane (Right)	0.4mm PE	2

PE-102L	Quarterdeck Hammock Crane (Left)	0.4mm PE	2
PE-103R	Quarterdeck Hammock Crane (Right)	0.4mm PE	2
PE-103L	Quarterdeck Hammock Crane (Left)	0.4mm PE	2
PE-104	Quarterdeck Breast Rail Hammock Crane	0.4mm PE	8
PE-105	Ladderway Stanchion	0.4mm PE	26
PE-106	0.9mm Standard Eyebolt	0.4mm PE	159
PE-107	Cannon carriage Cross Bar	0.4mm PE	24
PE-108	Bell Ring Bracket	0.4mm PE	1
PE-109	Gun Port Lid Eyebolt	0.4mm PE	32
PE-110	Bow Chase Port Lid Hinge	0.4mm PE	6
PE-111	Gun Port Lid Hinge	0.4mm PE	16
PE-111s	Stern Port Lid Hinge	0.4mm PE	6
PE-112L	Bow Trail board Decoration (Left)	0.4mm PE	1
PE-112R	Bow Trail board Decoration (Right)	0.4mm PE	1
PE-113	Galley Door Handle & Ring	0.4mm PE	10
PE-114	Ships Wheel Pattern	0.4mm PE	1
PE-115	Screen Bulkhead Window frame	0.4mm PE	4
PE-116	Screen Bulkhead Window frame	0.4mm PE	4
PE-117	Screen Bulkhead Window frame	0.4mm PE	4
PE-118	Screen Bulkhead Window frame	0.4mm PE	4
PE-119	Screen Bulkhead Door Handle	0.4mm PE	12
PE-120	Stern Decoration	0.4mm PE	1
PE-121	Stern Window Frame	0.4mm PE	1
PE-122	Stern Window Frame	0.4mm PE	1
PE-123	Stern Window Frame	0.4mm PE	1
PE-124	Stern Window Frame	0.4mm PE	1
PE-125	Stern Window Frame	0.4mm PE	1
PE-126	Stern Column Decoraration pattern	0.4mm PE	1
PE-127L	Stern Decoration (Left)	0.4mm PE	1
PE-127R	Stern Decoration (Right)	0.4mm PE	1
PE-128	Quarter Gallery Window Frame (Right)	0.4mm PE	1
PE-129	Quarter Gallery Window Frame (Right)	0.4mm PE	1
PE-130	Quarter Gallery Window Frame (Right)	0.4mm PE	1
PE-131	Quarter Gallery Window Frame (Left)	0.4mm PE	1
PE-132	Quarter Gallery Window Frame (Left)	0.4mm PE	1
PE-133	Quarter Gallery Window Frame (Left)	0.4mm PE	1
PE-134	Quarter Gallery Vertical Column (Right)	0.4mm PE	1
PE-135	Quarter Gallery Vertical Column (Right)	0.4mm PE	1
PE-136	Quarter Gallery Vertical Column (Right)	0.4mm PE	1
PE-137	Quarter Gallery Vertical Column (Right)	0.4mm PE	1

PE-138	Quarter Gallery Vertical Column (Left)	0.4mm PE	1
PE-139	Quarter Gallery Vertical Column (Left)	0.4mm PE	1
PE-140	Quarter Gallery Vertical Column (Left)	0.4mm PE	1
PE-141	Quarter Gallery Vertical Column (Left)	0.4mm PE	1
PE-142L	Quarter Gallery Decoration (Left)	0.4mm PE	1
PE-142R	Quarter Gallery Decoration (Right)	0.4mm PE	1
PE-143	Chain Pump Handle Eyebolt	0.4mm PE	8
PE-144	Yard Footrope Stirrup	0.4mm PE	42
PE-145	Hand Pump Handle Main Body (Left)	0.4mm PE	1
PE-146	Hand Pump Handle Main Body (Right)	0.4mm PE	1
PE-147	Hand Pump Handle Side Bracket	0.4mm PE	4
PE-148	Hand Pump Cap	0.4mm PE	2

0.4mm Photo-Etched Brass – Sheet 3

LPE/1	24 Foot Launch Main Floor	0.4mm PE	1
LPE/2	24 Foot Launch Bow Grating	0.4mm PE	1
LPE/3	24 Foot Launch Stern Floor Grating	0.4mm PE	1
LPE/4	24 Foot Launch Rudder Pattern (Right)	0.4mm PE	1
LPE/5	24 Foot Launch Rudder Pattern (Left)	0.4mm PE	1
LPE/6	24 Foot Launch Mast Strap	0.4mm PE	2
LPE/7	24 Foot Launch Eyebolt	0.4mm PE	2
PPE/1	28 Foot Pinnacle Main Floor	0.4mm PE	1
PPE/2	28 Foot Pinnacle Aft Floor Grating	0.4mm PE	1
PPE/3	28 Foot Pinnacle Stern Grating	0.4mm PE	1
PPE/4	28 Foot Pinnacle Rudder Pattern (Right)	0.4mm PE	1
PPE/5	28 Foot Pinnacle Rudder Pattern (Left)	0.4mm PE	1
PPE/6	28 Foot Pinnacle Rowlock	0.4mm PE	20
PPE/7	28 Foot Pinnacle Eyebolt	0.4mm PE	8
PPE/8	Boat Grapnel Main Pattern	0.4mm PE	2
PPE/9	Boat Grapnel Top Pattern	0.4mm PE	2
YPE/1	22 Foot Yawl Main Floor	0.4mm PE	1
YPE/2	22 Foot Yawl Bow Grating	0.4mm PE	1
YPE/3	22 Foot Yawl Stern Grating	0.4mm PE	1
YPE/4	22 Foot Yawl Rudder Pattern (Left)	0.4mm PE	1
YPE/5	22 Foot Yawl Rudder Pattern (Right)	0.4mm PE	1
YPE/6	22 Foot Yawl Eyebolt	0.4mm PE	8
YPE/7	Boat Hook	0.4mm PE	4
YPE/11	22 Foot Yawl Rowlock	0.4mm PE	14

0.6mm Photo-Etched Brass

PE-149	Chain Pump Handle bar (Aft)	0.6mm PE	2
PE-150	Chain Pump Handle bar (Fore)	0.6mm PE	2
PE-151	Boom Iron	0.6mm PE	2
PE-152	Scale Belaying Pin	0.6mm PE	66
PE-153	Rudder Spectacle Plate	0.6mm PE	1
PE-154	Lower Top Rail Stanchion	0.6mm PE	12
PE-155	Fore & Main Channel Boom Iron	0.6mm PE	4
PE-156	Rudder Gudgeon & Pintle Pattern	0.6mm PE	6
PE-157	Lower yard Inner Boom Iron	0.6mm PE	5
PE-158	Topsail yard Inner Boom Iron	0.6mm PE	5
PE-159	Lower yard Outer Boom Iron	0.6mm PE	5
PE-160	Topsail yard Outer Boom Iron	0.6mm PE	5
PE-161	Lower Stunsail Boom Hook	0.6mm PE	4

Fittings

F-1	Figurehead	Casting	1
F-2	Stern Decoration	Casting	1
F-3	Lantern Bottom	Casting	2
F-4	Lantern Top	Casting	2
F-5	9-Pounder Cannon barrel	Casting	20
F-6	Boat Beam Support Bracket	Casting	8
F-7	1.5mm Diameter Black Cannon Ball	Acrylic	100
F-8	Small pin	Brass	600
F-9	Ship's Bell	Brass	1
F-10	Binnacle Chimney	Brass	1
F-11	Rudder Chain – 150mm Approx.	Metal	1
F-12	2.5mm Thimble Block	Wood	20
F-13	3.5mm Thimble Block	Wood	20
F-14	5mm Deadeye	Wood	50
F-15	3mm Deadeye	Wood	80
F-16	2mm Single block	Wood	20
F-17	3mm Single block	Wood	100
F-18	4mm Single Block	Wood	30
F-19	5mm Single block	Wood	30
F-20	6mm Single Block	Wood	20
F-21	4mm Double block	Wood	30
F-22	5mm Double Block	Wood	20
F-23	Parrel bead	Plastic	70
F-24	Large mouse bead (Lower mast stays)	Plastic	6
F-25	Small mouse bead (Upper mast stays)	Plastic	6

Materials

F-26	0.1mm Diameter natural thread		100m
F-27	0.25mm Diameter natural thread		100m
F-28	0.5mm Diameter natural thread		20m
F-29	0.75mm Diameter natural thread		20m
F-30	0.01mm Diameter black thread (Ratlines)		30m
F-31	0.25mm Diameter black thread		20m
F-32	0.5mm Diameter black thread		20m
F-33	0.75mm Diameter black thread		20m
F-34	1mm Diameter black thread		20m
F-35	1.3mm Diameter black thread		2m
F-36	2mm Diameter natural thread (Anchor hawse)		0.5m
F-37	8mm Dowel x 500mm long	Wood	3
F-38	6mm Dowel x 500mm long	Wood	3
F-39	5mm Dowel x 500mm long	Wood	1
F-40	4mm Dowel x 500mm long	Wood	3
F-41	3mm Dowel x 500mm long	Wood	4
F-42	2mm Dowel x 500mm Long	Wood	1
F-43	1mm x 5mm x 650mm strip - Limewood	Wood	50
F-44	0.8mm x 4mm x 650mm strip - Second planking	Wood	70
F-45	1mm Diameter brass rod x160mm long (Approx.)	Metal	1
F-46	0.7mm Diameter brass rod x 160mm long (Approx.)	Metal	1
F-47	Black Cartridge paper (For anchor & Mast Straps)	Paper	1

Sphinx Laser and PE Sheet Quantities

3mm MDF Laser Cut	2
4mm MDF Laser Cur	2
2mm MDF Laser cut	1
2mm Birch Plywood	1
2mm Clear Acetate	1
0.5mm Clear Acetate	1
0.6mm Pear Wood x 500mm long	4
0.8mm Pear Wood x 600mm long	2
1mm Pear Wood - 5 x 500mm long plus 1 x 250mm long	6
1mm Pear Wood x 600mm long	1
1.5mm Pear Wood	3
2mm Pear Wood (Including anchor stock patterns)	2
3mm Pear Wood	2
4mm Pear Wood	1
0.8mm Plywood	2
0.8mm Maple Veneer laser etched deck	2
0.2mm Photo Etched Brass Sheet	1
0.4mm Photo Etched Brass Sheet	3
0.6mm Photo Etched Brass Sheet	1

Disclaimer

In our continuing effort to improve our product we reserve the right to change plans, features, specifications, prices and materials without notice or obligation.

Wood is a natural material and whilst we try hard to attain an even colour/shade in each batch, this cannot always be guaranteed, even with the highest quality materials Vanguard Models uses. Where there is colour variation, for example, planks, try to utilise these appropriately (darker/lighter planks below the waterline etc.)

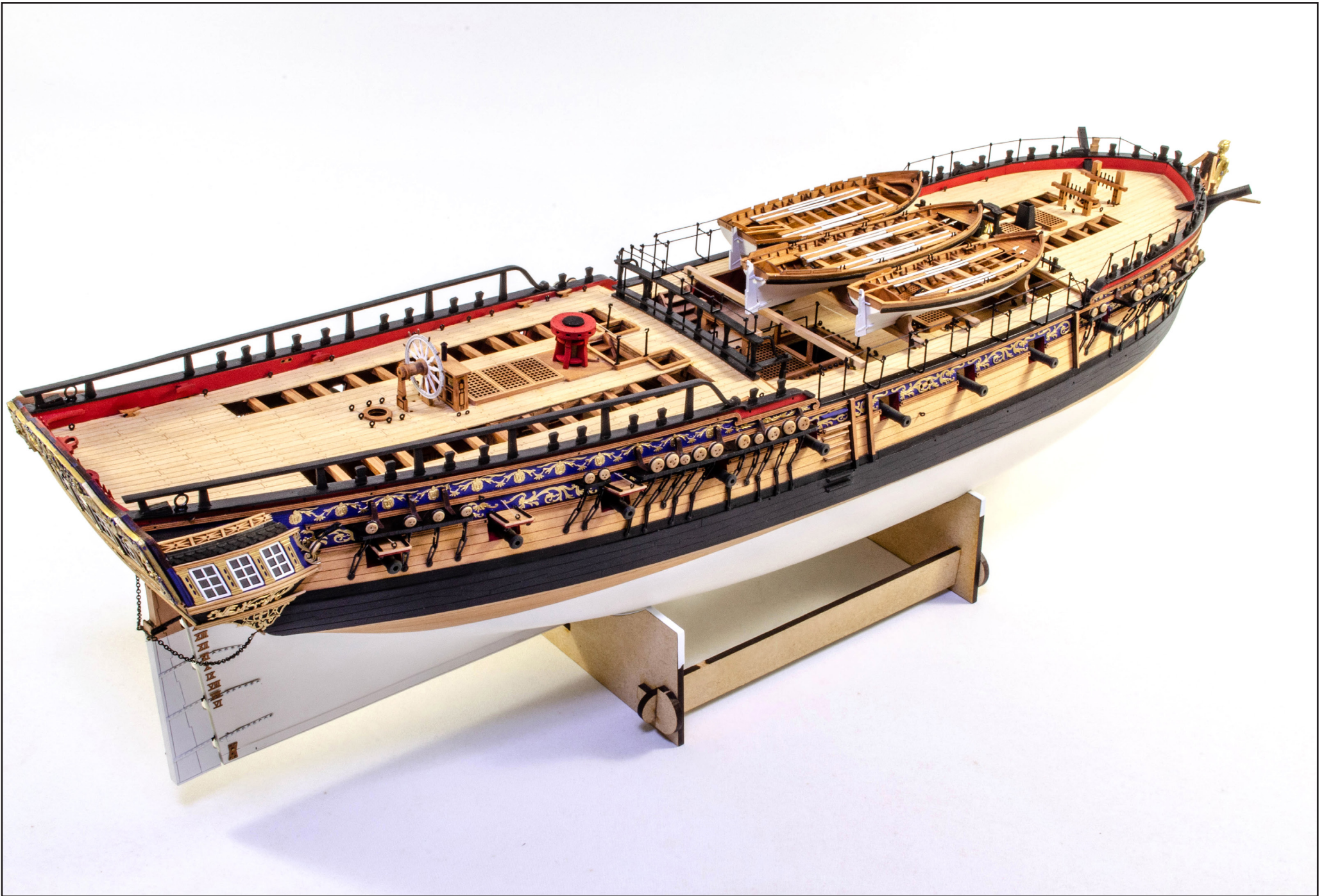

VANGUARD MODELS

BY CHRIS WATTON

©Vanguard Models is a subsidiary of Burncroft Limited

Registered Office:

70B, High Street

Cinderford

Gloucestershire

GL14 2SZ

UK

Tel (0044) [0]1594 824610

Registered company number – 04317996

Website - www.vanguardmodels.co.uk

Email - sales@vanguardmodels.com

HMS Sphinx was designed and developed in the UK by Chris Watton

Finished prototype model made and photographed (including construction manual text) by James Hatch

06/08/2021